

Specifications



MD 115



MD 90



MD 70



MD 50



MD 40



MFS 30



MFS 25

T L D I

Model	MD115	MD90	MD70	MD50	MD40	MFS30	MFS25	
No. of Cylinder	4	3			3			
Output	115hp (84.6 kw)	90 hp (66.2 kw)	70 hp (51.5 kw)	50 hp (36.8 kw)	40 hp (29.4 kw)	30 hp (22.1 kw)	25 hp (18.4 kw)	
Displacement	1768 cc (107.9 cu.in)	1267 cc (77.3 cu.in)		697 cc(42.5 cu.in)		526 cc (32.09 cu.in)		
Bore x Stroke	88 x 72.7 mm (3.46 x 2.86 in)	86 x 72.7 mm (3.39 x 2.86 in)		68 x 64 mm (2.68 x 2.52 in)		61 x 60 mm (2.4 x 2.36 in)		
Max. RPM Range	5,150 - 5,850			5,250 - 6,250		5,000 - 6,000		
Starting	Electric							
Control Type	Remote Control			Remote Control or Tiller Handle				
Gear Shift	Forward - Neutral - Reverse							
Gear Ratio	2.0:1	2.3:1		1.85:1		1.92:1		
Propeller Selection Range	11" - 21"			7" - 15"		8" - 14"		
Transom Height	20", 25"		20"		15", 20"		15", 20"	
Fuel	Unleaded Gasoline (87 Octane)							
Recommended Oil	Tohatsu Premium Outboard Motor Oil							
Fuel Tank	Optional					6.6 US Gal. (25 Lit) Separate Tank		
Weight*	392 lbs (178 kg)	315 lbs (143 kg)		205.7 lbs (93.5 kg)		161 lbs (73 kg)	157.6 lbs (71.5 kg)	
Alternator Output	12V, 490W, 40A	12V, 280W, 23A			12V, 180W, 15A			
Model	MD115	MD90	MD70	MD50	MD40	MFS30	MFS25	
Electronic Fuel Injection	-	-	-	-	-	S	S	
Direct Fuel Injection	S	S	S	S	S	-	-	
Digital CD Ignition System	-	-	-	-	-	S	S	
Inductive Ignition System	S	S	S	S	S	-	-	
Start In Gear Protection	S	S	S	S	S	S	S	
Thermostat Controlled Cooling System	S	S	S	S	S	S	S	
Through-The-Prop Exhaust	S	S	S	S	S	S	S	
Shallow Water Drive	-	-	-	-	-	O	O	
Oil Pressure Warning	-	-	-	-	-	S	S	
Power Trim and Tilt	S	S	S	S	S	S	O	
Power Tilt	-	-	-	-	-	-	-	
Gas Assist Tilt	-	-	-	-	-	O	O	
Variable Idle Speed	700, 800, 900 rpm					-	-	

* Weight Specification is based on the lightest version.

*** 4hp includes an External Fuel Tank Connector installed on engine to allow user to use an optional external fuel tank

**** Alternator std on Certain Models

LEGEND S Standard Features O Optional or Certain Models
 Specifications and descriptions are subject to change without notice.

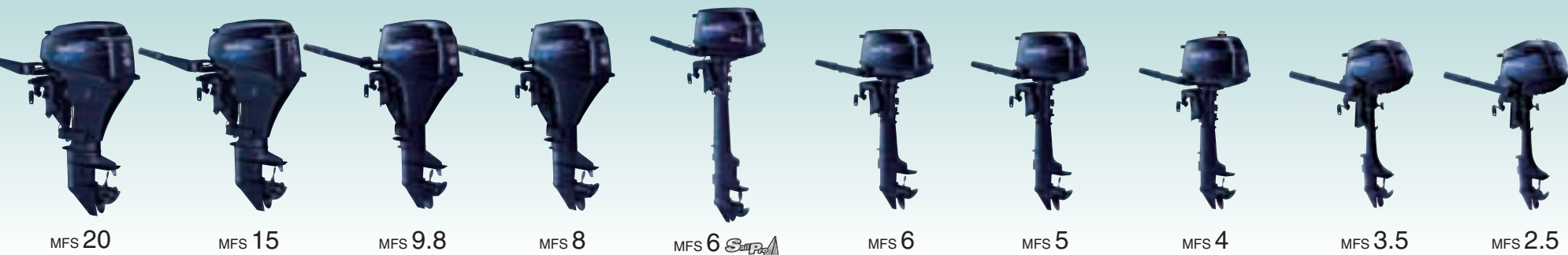

F o u r S t r o k e

MFS20	MFS15	MFS9.8	MFS8	MFS6 Sail Pro	MFS6	MFS5	MFS4	MFS3.5	MFS2.5	
2				1						
20 hp (14.7 kw)	15 hp (11 kw)	9.8 hp (7.2 kw)	8 hp (5.9 kw)	6 hp (4.4 kw)		5 hp (3.7 kw)	4 hp (2.9 kw)	3.5 hp (2.6 kw)	2.5 hp (1.8 kw)	
351 cc (21.41 cu.in)		209 cc (12.8 cu.in)		123 cc (7.5 cu.in)			85.5 cc (5.2 cu.in)			
61 x 60 mm (2.4 x 2.36 in)		55 x 44 mm (2.17 x 1.73 in)		59 x 45 mm (2.32 x 1.77 in)			55 x 36 mm (2.17 x 1.42 in)			
5,400 - 6,100	5,000 - 6,000		5,000 - 6,000		4,500 - 5,500		5,000 - 6,000	4,500 - 5,500		
Electric & Manual or Manual				Manual						
Remote Control or Tiller Handle				Tiller Handle or Opt. Remote Control				Tiller Handle		
Forward - Neutral - Reverse								Forward - Neutral		
2.15:1		2.08:1		2.15:1						
7" - 11.5"		5" - 9.5"		6"	6" - 9"			4.5" - 7"		
15", 20"		15", 20", 25"	15", 20"	25"	15", 20"		15", 20"			
Unleaded Gasoline (87 Octane)										
Tohatsu 4stroke Outboard Motor Oil										
3.1 US Gal. (12 Lit) Separate Tank							0.34 US Gal. (1.3 Lit) Integral Tank***	0.26 US Gal. (1 Lit) Integral Tank		
114 lbs (51.5 kg)		81.5 lbs (37 kg)		59 lbs (27 kg)	55 lbs (25 kg)		57 lbs (26 kg)	41 lbs (18.4 kg)		
12V, 145W, 12A		12V, 80W, 6A****		12V, 60W, 5A	Opt. 12V, 60W, 5A		N/A			
MFS20	MFS15	MFS9.8	MFS8	MFS6 SailPro	MFS6	MFS5	MFS4	MFS3.5	MFS2.5	
-	-	-	-	-	-	-	-	-	-	
-	-	-	-	-	-	-	-	-	-	
S	S	S	S	S	S	S	S	S	S	
-	-	-	-	-	-	-	-	-	-	
S	S	S	S	S	S	S	S	-	-	
S	S	S	S	S	S	S	S	S	S	
S	S	S	S	S	S	S	S	-	-	
S	S	S	S	S	S	S	S	-	-	
S	S	S	S	S	S	S	S	-	-	
O	O	O	-	-	-	-	-	-	-	
-	-	-	-	-	-	-	-	-	-	
-	-	-	-	-	-	-	-	-	-	
-	-	-	-	-	-	-	-	-	-	