

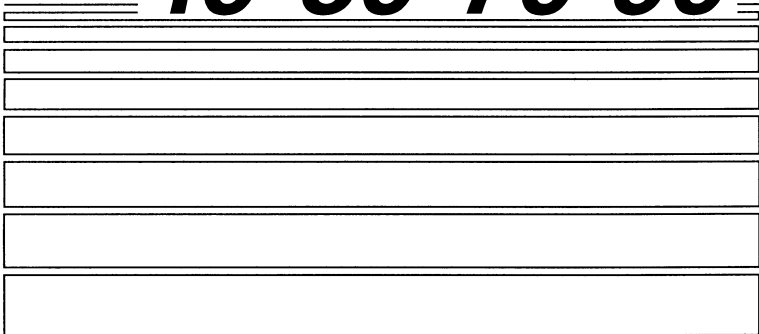

TLDI

40•50•70•90



OWNER'S MANUAL

Copyright © 2007 Tohatsu Corporation. All rights reserved. No part of this manual may be reproduced or transmitted in any form or by any means without the express written permission of Tohatsu Corporation.

YOUR TOHATSU OUTBOARD MOTOR

OWNER REGISTRATION AND IDENTIFICATION

Upon purchasing this product, be sure your dealer* fills out the WARRANTY CARD correctly, completely and mails it to the distributor. This card identifies you as the legal owner of the product and serves as your warranty registration. If this procedure is not followed, your outboard motor will not be covered by warranty.

* : In this manual, “dealer” always means an authorized TOHATSU dealer.

PRE-DELIVERY CHECK

Be sure that the product has been checked by the dealer before delivery.

Limited Warranty

This TOHATSU product is fully guaranteed against defective materials and workmanship for the period from the date of purchase, provided that the purchase has been registered in accordance with the above.

The limited warranty will not apply to the normal wear and tear of parts, adjustments, tune-ups, or to any damage caused by, but not limited to:

- 1) Use or operation NOT conforming to the instructions described in this owner’s manual.
- 2) Participation in or preparation for racing or other competitive activities.
- 3) Water entering the engine.
- 4) Damage from accidents, collisions, contact with foreign materials, or submersion.
- 5) Growth of marine organisms on motor surfaces.
- 6) Any other careless use or operation.
- 7) Normal deterioration.

The limited warranty does not cover maintenance items. The following items are a few examples not covered by the limited warranty:

Spark plugs, Anode, Trim-tab, Propeller, Fuel filter, Oil filter, Carbon brush, Starter rope, Shear-pin, Split-pin, Bolt-nut-washer, Wire cable, Rubber goods: water pump impeller, oil seal, “O”-ring, fuel hose, primer bulb, vinyl tube etc.

The limited warranty will become void if the product has been altered, modified, or repaired by anyone other than a company or service firm authorized by TOHATSU.

The limited warranty will cover only your TOHATSU product and will not cover the boat the product is mounted on, the trailer, equipment, or accessories associated with the product.

Serial Number

In the space below, please record the engine's serial number (indicated both on the lower motor cover and on the cylinder block). This number will come in handy in the event of theft or to help in quickly identifying the product type.

Serial Number : _____

To You, Our Customer:

Thank you for selecting a TOHATSU product. You are now the proud owner of an excellent outboard engine that will service you for many years to come.

We would like to point out that carefree usage can only be assured on condition that this manual is read through in its entirety and the maintenance routines described later in this manual are followed carefully. Should difficulty arise with the engine, please follow the troubleshooting procedures listed at the end of this manual. If the problem persists, contact an authorized TOHATSU service shop or your dealer.

We hope you will get much enjoyment from this product and wish you good luck in your boating adventures.

TOHATSU CORPORATION

NOTICE: DANGER/WARNING/CAUTION/Note

Before operating your outboard motor, be sure to thoroughly read and understand this Owner's Manual and follow all of the instructions shown. Of particular importance is information preceded by the words "DANGER," "WARNING," "CAUTION," and "Note." Always pay special attention to such information to ensure safe and trouble-free operation at all times.

DANGER

Failure to observe will result in severe personal injury or death.

WARNING

Failure to observe could result in severe personal injury or death.

CAUTION

Failure to observe could result in personal injury, or product or property damage.

Note:

This instruction provides special information to facilitate the use or maintenance of the outboard or to clarify important points.

EMERGENCY STOP SWITCH

The Emergency stop switch will stall the engine when the stop switch tether is pulled out. This line can be attached to the body of the operator, effectively preventing injuries from the propeller in case he/she falls overboard.

We highly recommend use of the Emergency stop switch line. However, we would also like to point out the drawbacks of the switch. Accidental activation of the switch (such as the line being pulled out in heavy seas) could cause passengers to lose their balance and even fall overboard, or it could result in loss of power in heavy seas, strong currents, or high winds. Loss of control while mooring is another potential hazard.

To prevent such hazardous situations, the 500 mm (20 inch.) line is coiled and can be extended to a full 1,300 mm (51 inch.).

WARNINGS

As the operator/driver of the boat, you are responsible for the safety of those aboard and those in other crafts around yours, and for following local boating regulations. Therefore you should possess thorough knowledge of correct operation of the boat, engine, and accessories. To learn about the correct operation and maintenance of the engine, please read through this manual carefully.

It is very difficult for a person standing or floating in the water to take evasive action should he or she see a power boat heading in his/her direction, even at a slow speed. Therefore, when your boat is in the immediate vicinity of people in the water, the engine should be shifted to neutral and shut off.

SERIOUS INJURY IS LIKELY IF A PERSON IN THE WATER MAKES CONTACT WITH A MOVING BOAT, GEAR HOUSING, PROPELLER, OR ANY SOLID DEVICE RIGIDLY ATTACHED TO A BOAT OR GEAR HOUSING.

It is the operator's responsibility to perform all safety checks and to ensure that all lubrication and maintenance instructions are complied with for safe operation. It is also the operator's responsibility to return the unit to the local dealer for periodic inspection.

Correct periodic maintenance and proper care of this outboard engine will lessen the chance of problems and keep overall operating expenses at a minimum.

SERVICING, REPLACEMENT PARTS & LUBRICANTS

Only let an authorized TOHATSU service shop perform service or maintenance on this product. Be sure to use genuine parts, genuine lubricants, or recommended lubricants.

MAINTENANCE

As the owner of this outboard engine, you must be acquainted with correct maintenance procedures. Please comply with all instructions concerning lubrication and maintenance, and you should return the engine to the dealer, or service shop, for periodic inspection at the prescribed intervals.

Troublefree operation cannot be expected unless the engine receives adequate periodic maintenance. If proper maintenance is performed, it is not likely that a costly repair will ever be required.

USE OF SERVICE SHOP

We recommend that you use only authorized dealers to carry out all of your maintenance and repair needs.

CONTENTS

	Page
1. Specifications	1
2. Names of parts	4
3. Engine Installation on Boa	9
1 Installation	9
2 Stern Bracket Dimensional Drawing	11
3 Propeller Selection	12
4. Remote Control Device & Meters	13
1 Installation of the Remote Control Cables (Box side)	13
2 Installation of the Remote Control Box on your boat	13
3 Connecting the Remote Control Cable to the Engine	13
4 Connecting Cords and Cables	20
5 Installing the Meters	20
6 Installing the Drag Link Assembly	23
7 Battery	24
5. Fuel and Engine Oil	26
6. Running	29
1 Break-in	29
2 Starting	30
3 Warm-up	39
4 Warning System	40
7. Operation	44
1 Forward/Reverse Running	44
2 Shallow Water Running	46
3 Stopping the Engine	48

8. Trim Adjustment	50
9. Mooring with the Engine Tilted up	54
10. Removing and Carrying the Motor	58
11. Adjustments	61
1 Remote Control Lever Load	61
2 Trim Tab Adjustment	61
3 Steering Load Adjustment	62
4 Throttle Grip Turning Load Adjustment	62
12. Inspection and Maintenance	63
1 Daily Inspection	64
2 Periodic Inspection	69
1) Changing Gear Oil	71
2) Cleaning Tanks and the Filters	72
3) Checking and Refilling Oil in the Power Trim & Tilt Unit	73
13. Off-season Storage	75
1 Engine	75
2 Battery	76
3 Electric Starter Motor	76
14. Pre-season Check	77
15. Checking after Striking Underwater Object	78
16. If the Engine Becomes Submerged in Water	78
17. Precautions in Cold Weather	79
18. Troubleshooting	79
19. Tool Kit and Spare Parts	82
20. Propeller Table	83
21. Optional Accessories	84

1. SPECIFICATIONS 40B • 50B

MODEL		40B		50B	
		EPTO	EFTO	EFO	EFO
Overall Length	mm (in)	630 (24.8)		1,120 (44.1)	
Overall Width	mm (in)	345 (13.6)		384 (15.1)	
Overall Height	S • L • UL mm (in)	1,227 (48.3) • 1,354 (53.3) • 1,481 (58.3)			
Transom Height	S • L • UL mm (in)	403 (15.9) • 530 (20.9) • 657 (25.9)			
Weight	S kg (lb)	93.5 (206)	96.5 (213)	88.5 (195)	
	L kg (lb)	94.5 (208)	97.5 (215)	89.5 (197)	
	UL kg (lb)	97 (214)	100 (220)	92 (203)	
Output	Kw (Hp)	29.4 (40)		36.8 (50)	
Max. Operating Range	rpm	5,150 – 5,850			
Engine Type		Direct fuel injection			
Number of Cylinder		3			
Bore × Stroke	mm (in)	68 × 64 (2.68 × 2.52)			
Piston Displacement	mL (Cu in)	697 (42.5)			
Exhaust System		Through hub exhaust			
Cooling System		Water cooling			
Engine Lubrication		Oil injection			
Starting System		Electric starter motor			
Ignition System		Inductive Ignition			
Spark Plug		NGK PZFR6H			
Alternator		12V, 280W (Max.)			
Trim Position		4		6	
Engine Oil		Genuine Motor Oil or recommended one			
Gear Oil		Genuine Gear Oil or API GL5, SAE #80 to #90, approx. 500 mL			
Fuel Tank Capacity	L (US gal)	25 (6.6)			
Engine Oil Capacity	L (US gal)	Approx. 2.0 (0.53)			
Gear Reduction Ratio		1.85 (13 : 24)			
Fuel		Unleaded regular gasoline pump posted 87 Octane (research octane rating of 91)			

1. SPECIFICATIONS W50B

Item		MODEL	W50B	
			EPTO	EFTO
Overall Length	mm (in)	630 (24.8)	1,120 (44.1)	
Overall Width	mm (in)	345 (13.6)	384 (15.1)	
Overall Height	L · UL mm (in)	1,415 (55.7) · 1,542 (60.7)		
Transom Height	L · UL mm (in)	550 (21.7) · 677 (26.7)		
Weight	L kg (lb)	100.5 (222)	103.5 (228)	
	UL kg (lb)	101.5 (224)	104.5 (230)	
Output	Kw (Hp)	36.8 (50)		
Max. Operating Range	rpm	5,150—5,850		
Engine Type		Direct fuel injection		
Number of Cylinder		3		
Bore × Stroke	mm (in)	68 × 64 (2.68 × 2.52)		
Piston Displacement	mL (Cu in)	697 (42.5)		
Exhaust System		Through hub exhaust		
Cooling System		Water cooling		
Engine Lubrication		Oil injection		
Starting System		Electric starter motor		
Ignition System		Inductive Ignition		
Spark Plug		NGK PZFR6H		
Alternator		12V, 280W (Max.)		
Trim Position		4		
Engine Oil		Genuine Motor Oil or recommended one		
Gear Oil		Genuine Gear Oil or API GL5, SAE #80 to #90, approx. 700 mL		
Fuel Tank Capacity	L (US gal)	25 (6.6)		
Engine Oil Capacity	L (US gal)	Approx. 2.0 (0.53)		
Gear Reduction Ratio		1.92 (12 : 23)		
Fuel		Unleaded regular gasoline pump posted 87 Octane (research octane rating of 91)		

1. SPECIFICATIONS 70B • 90B

Item	MODEL	70B	90B
		EPTO	
Overall Length	mm (in)	747 (29.4)	
Overall Width	mm (in)	390 (15.4)	
Overall Height	L • UL mm (in)	1,477 (58.1) • 1,604 (63.1)	
Transom Height	L • UL mm (in)	517 (20.4) • 644 (25.4)	
Weight	L • UL kg (lb)	143 (315) • 146 (322)	
Output	Kw (Hp)	51.5 (70)	66.2 (90)
Max. Operating Range	rpm	5,150–5,850	
Engine Type		Direct fuel injection	
Number of Cylinder		3	
Bore × Stroke	mm (in)	86 × 72.7 (3.39 × 2.86)	
Piston Displacement	mL (Cu in)	1267 (77.3)	
Exhaust System		Through hub exhaust	
Cooling System		Water cooling	
Engine Lubrication		Oil injection	
Starting System		Electric starter motor	
Ignition System		Inductive ignition	
Spark Plug		NGK PZFR6H	
Alternator		12V, 280W (Max.)	
Trim Position		2	
Engine Oil		Genuine Motor Oil or recommended one	
Gear Oil		Genuine Gear Oil or API GL5, SAE #80 to #90, approx. 900 mL	
Fuel Tank Capacity	L (US gal)	25 (6.6)	
Engine Oil Capacity	L (US gal)	Approx. 4.0 (1.06)	
Gear Reduction Ratio		2.33 (12 : 28)	2.0 (13 : 26)
Fuel		Unleaded regular gasoline pump posted 87 Octane (research octane rating of 91)	

2. NAMES OF PARTS

EFO

40B · 50B

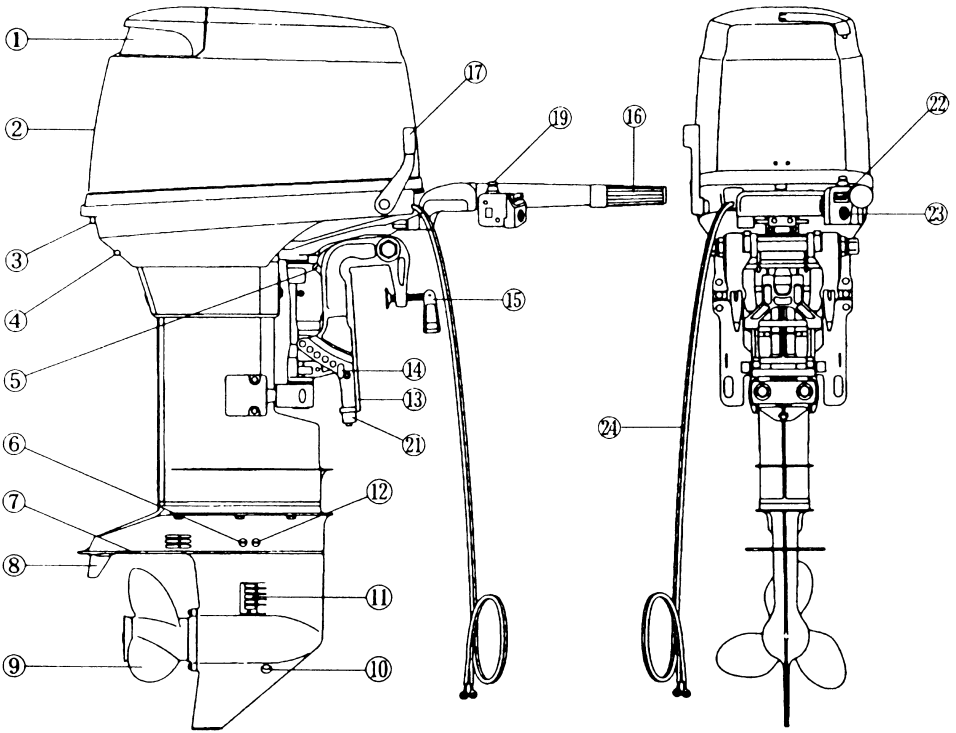

- ① Tilt Handle
- ② Upper Motor Cover
- ③ Hook Lever
- ④ Water Check Port
- ⑤ Reverse Lock Lever
- ⑥ Water Plug
- ⑦ Anti-ventilation Plate
- ⑧ Trim Tab
- ⑨ Propeller
- ⑩ Oil Plug (lower)
- ⑪ Water Strainer
- ⑫ Oil Plug (upper)
- ⑬ Stern Bracket
- ⑭ Thrust Rod
- ⑮ Clamp Screw
- ⑯ Throttle Grip
- ⑰ Shift Lever
- ⑱ Stop Switch
- ⑲ Anode
- ⑳ Pilot Lamp

- ㉑ Main Switch
- ㉒ Battery Cords

EFTO

40B · 50B · W50B

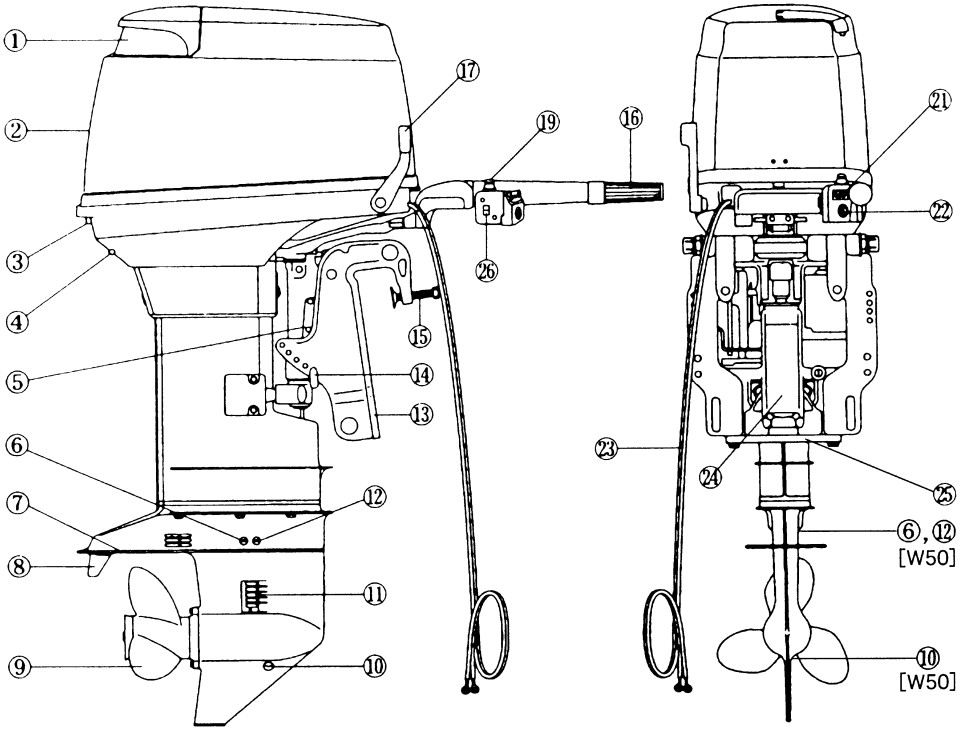

- ① Tilt Handle
- ② Upper Motor Cover
- ③ Hook Lever
- ④ Water Check Port
- ⑤ Tilt Stopper
- ⑥ Water Plug
- ⑦ Anti-ventilation Plate
- ⑧ Trim Tab
- ⑨ Propeller
- ⑩ Oil Plug (lower)

- ⑪ Water Strainer
- ⑫ Oil Plug (upper)
- ⑬ Stern Bracket
- ⑭ Thrust Rod
- ⑮ Clamp Screw
- ⑯ Throttle Grip
- ⑰ Shift Lever
- ⑱ Stop Switch
- ⑲ Pilot Lamp
- ⑲ Main Switch

- ⑳ Battery Cords
- ㉑ Power Trim & Tilt
- ㉒ Anode
- ㉓ Power Trim & Tilt Switch

EPTO

40B · 50B · W50B

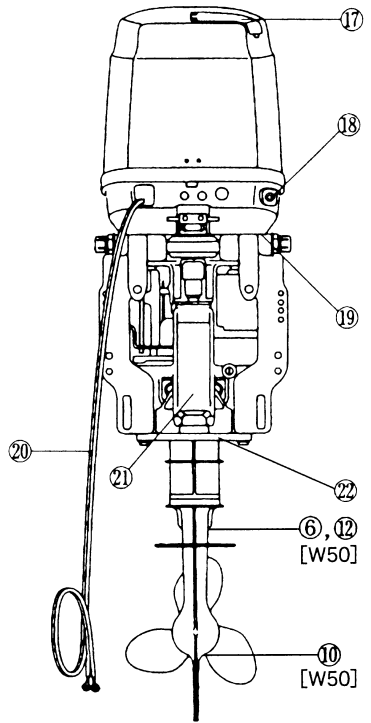
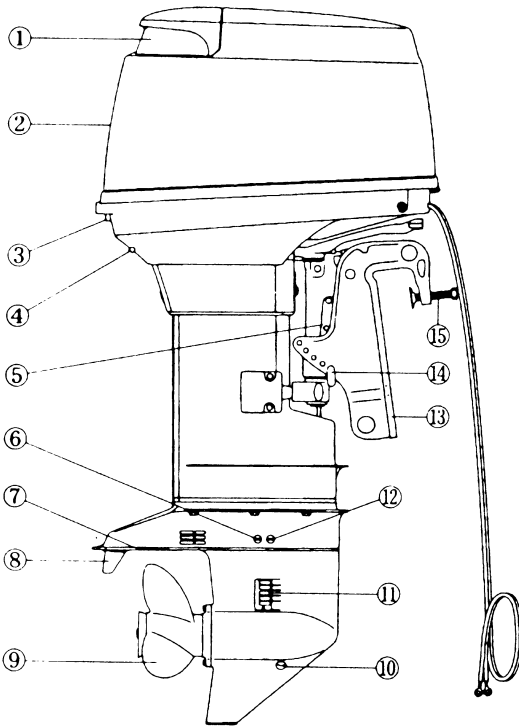

- ① Tilt Handle
- ② Upper Motor Cover
- ③ Hook Lever
- ④ Water Check Port
- ⑤ Tilt Stopper
- ⑥ Water Plug
- ⑦ Anti-ventilation Plate
- ⑧ Trim Tab
- ⑨ Propeller
- ⑩ Oil Plug (lower)

- ⑪ Water Strainer
- ⑫ Oil Plug (upper)
- ⑬ Stern Bracket
- ⑭ Thrust Rod
- ⑮ Clamp Screw
- ⑯ Filler Lid
- ⑰ Fuel Connector
- ⑱ Power Trim & Tilt Switch
- ⑳ Battery Cords
- ㉑ Power Trim & Tilt

㉒ Anode

EPTO

70B · 90B

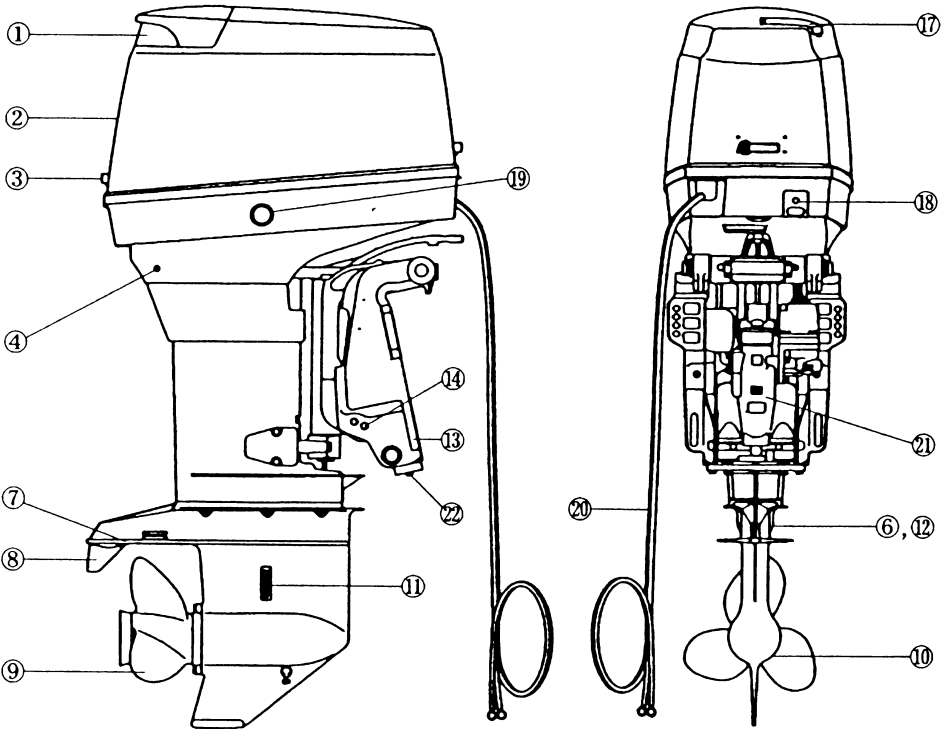

- | | |
|--------------------------|----------------------------|
| ① Tilt Handle | ⑫ Oil Plug (upper) |
| ② Upper Motor Cover | ⑬ Stern Bracket |
| ③ Hook Lever | ⑭ Thrust Rod |
| ④ Water Check Port | ⑰ Filler Lid |
| ⑥ Water Plug | ⑱ Power Trim & Tilt Switch |
| ⑦ Anti-ventilation Plate | ⑳ Battery Cords |
| ⑧ Trim Tab | ㉑ Power Trim & Tilt |
| ⑨ Propeller | ㉒ Anode |
| ⑩ Oil Plug (lower) | |
| ⑪ Water Strainer | |

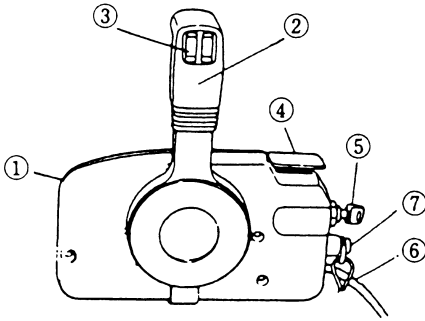

for EPTO Type

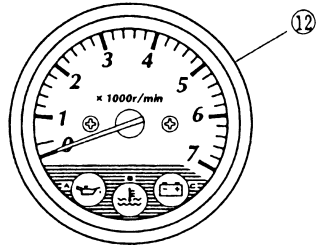

for EPTO Type

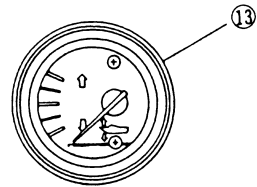
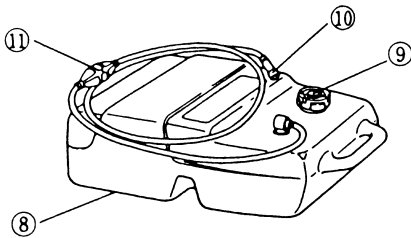

for EPTO Type

- | | |
|----------------------------|---------------|
| ① Remote Control Box | ⑪ Primer Bulb |
| ② Remote Control Lever | ⑫ Tachometer |
| ③ Power Trim & Tilt Switch | ⑬ Trim Meter |
| ④ Neutral Warm-up Lever | |
| ⑤ Main Switch | |
| ⑥ Harness B | |
| ⑦ Stop Switch | |
| ⑧ Fuel Tank | |
| ⑨ Air Vent Screw | |
| ⑩ Fuel Connector | |

3. ENGINE INSTALLATION ON BOAT

⚠ WARNING

Most boats are rated and certified in terms of their maximum horsepower, and this is shown on the boat's certification plate. Do not equip your boat with an outboard that exceeds this limit. If in doubt, contact your dealer.

Do not operate the engine until it has been securely mounted on the boat in accordance with the instructions below.

Note:

Consult your authorized dealer to receive the proper instructions or ask your dealer to mount the motor as necessary.

1 Installation

① Single-engine Installation

- Position the outboard engine at the exact center of the stern, and mount it using a cushioning pad or plate. (Fig. 1)

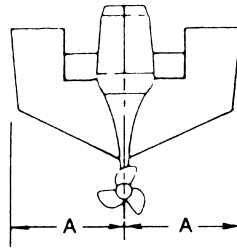

(Fig. 1)

② Twin-engine Installation

- Position the outboard engines 470~660mm (18.5 ~ 26.0 in.) apart, measured from an imagined center line of each engine, in the exact center of the stern. (Fig. 2)

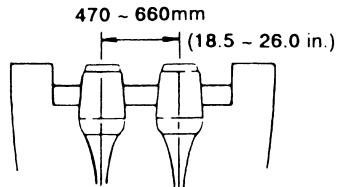

(Fig. 2)

③ Transom Height

Install the engine with the Anti-ventilation Plate at a level 10 ~ 30mm below the bottom of the boat. (Fig. 3)

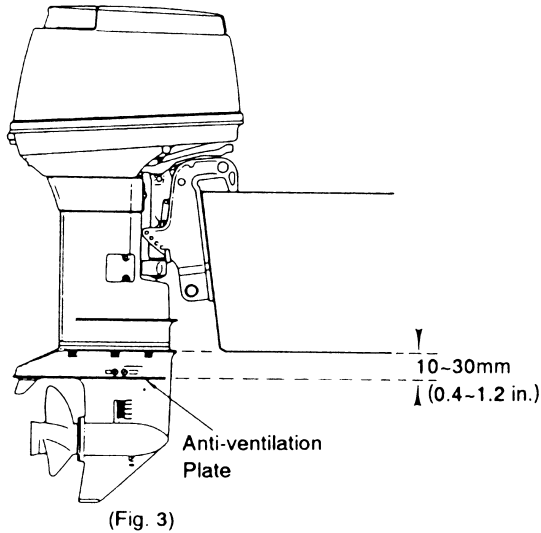

Transom Matching

Be sure that the anti-ventilation plate of the outboard is below the water surface when running with wide open throttle.

In case the above condition cannot be met due to the shape of your boat, please consult your dealer.

▲ CAUTION

Overheating may occur if the Anti-ventilation Plate is at a level higher than the bottom of the boat, as a result of a lack of cooling water.

- If the height difference exceeds 10 ~ 30mm engine power performance is likely to be reduced as a result of increased water resistance to the gear case assembly.

④ Attaching the Stern Bracket

After positioning the Stern Bracket, fix it with clamp screws then drill four holes in the transom board, matching the holes in the Stern Bracket. Secure

the engine with the supplied bolts (M12 x 105mm) and nuts. Be sure to use the washers. Use the larger diameter washers inside of the transom board and use the small diameter washers outside of the stern bracket. The mounting holes may be drilled beforehand by referring to the dimensional drawing.

2 Stern Bracket Dimensional Drawing

manual tilting model **EFO 40 • 50**

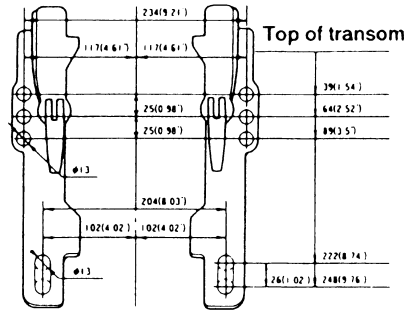
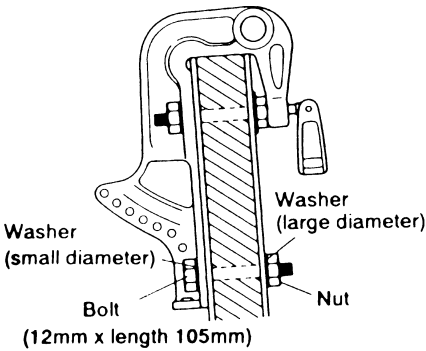

with the Power Trim and Tilt model **EFTO • EPTO 40 • 50**

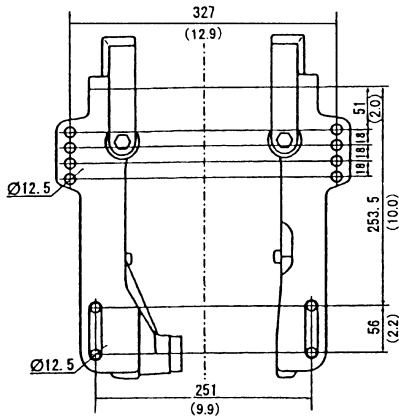
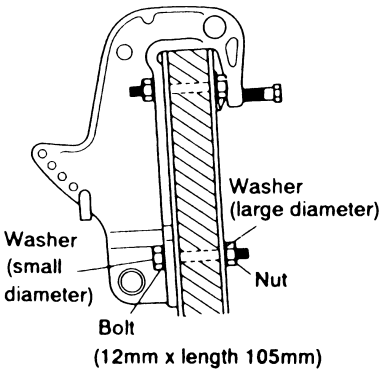

Power Trim and Tilt model EPTO 70 • 90

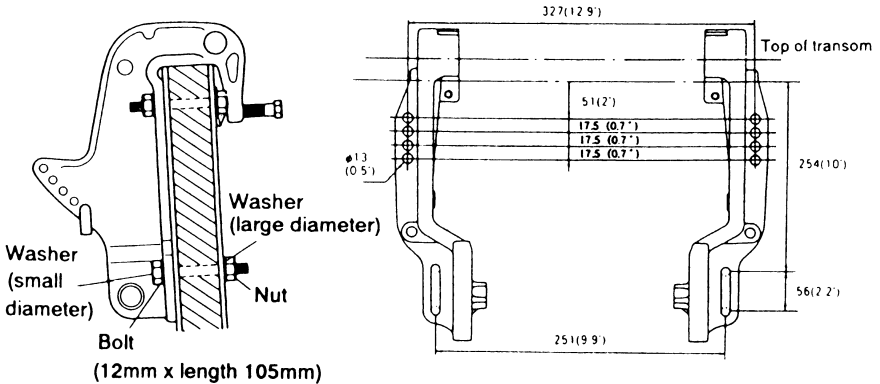

Note:

We recommend that the bolt head of the upper bolts face inward while the nuts are kept on the outside of the boat to prevent injury to the passengers.

Notes:

1. Apply sealing agent, such as silicon sealer, between the bolts and the transom board holes when tightening the bolt.
2. Be sure to fix the engine securely with the bolts.

3 Propeller Selection

A propeller must be selected so that the engine rpm measured at wide open throttle while cruising is within the recommended range;
5150 to 5850 rpm

For genuine propellers, refer to Propeller Table of this manual.

4. REMOTE CONTROL DEVICE & METERS

40 • 50 • 70 • 90

It is recommended you consult with your dealer for installation and adjustment of the remote control device.

1 Installation of the Remote Control Cables (Box side)

Follow the instruction manual provided with the remote control box.

2 Installation of the Remote Control Box on your boat

Follow the instruction manual provided with the remote control box.

3 Connecting the Remote Control Cable to the engine.

40 • 50

① Detach the upper engine cover by turning the lever.

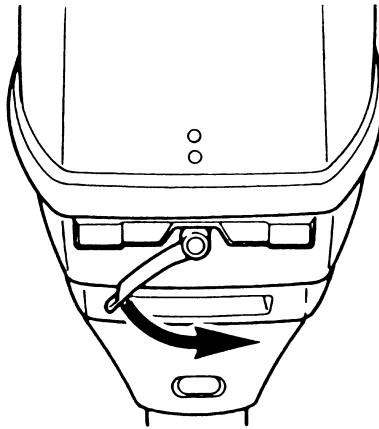

- ② Detach the bracket and set Cable Harness B and Remote Control Cables. Having fixed the Remote Control Cables to the bracket, tie them to the lower engine cover.

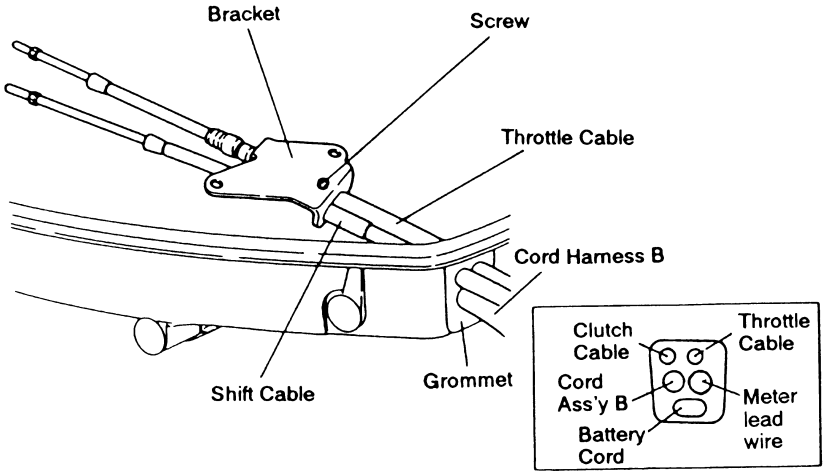

- ③ Detach the throttle and shift cable joints by removing the R-shaped pins.

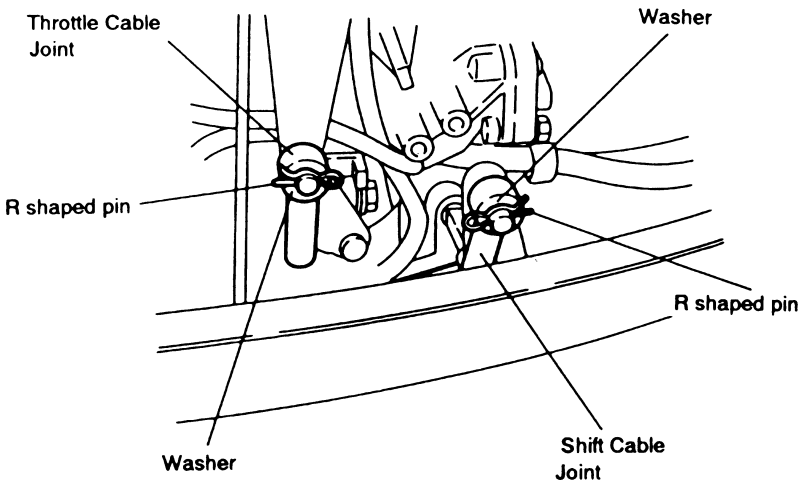

- Screw the tip of the remote control cable into the cable joint up to approx. 10 mm (0.39 inch), then lock them with a lock nut. Here, apply grease to the hole of the cable joint.

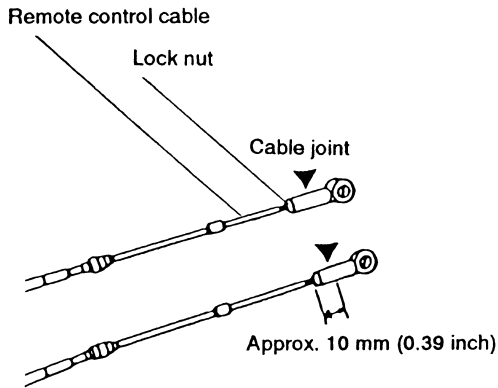

- ④ Move the Remote Control lever Forward, to Neutral and to Reverse to confirm the shift is working, and then set the lever to Neutral.

- Double-check that the Remote Control Cables, the throttle cable and shift cable have been connected correctly. Move the Remote Control Lever Forward until the first engaging point (approx. 32°). The cable which is moved first when the lever is turned is a shift cable. Check that the shift lever is in Neutral and the neutral warm-up lever is fully closed when the remote control cables have been connected.

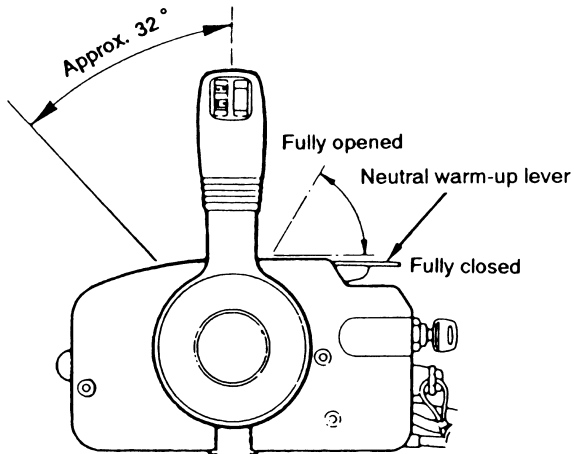

- ⑤ Set the shift arm to the [N] position and close the advancer arm completely.
If the advancer arm does not contact with the stopper, the throttle position sensor will be active improperly.

- The advancer arm should have contact with the stopper at neutral position of the remote control lever.

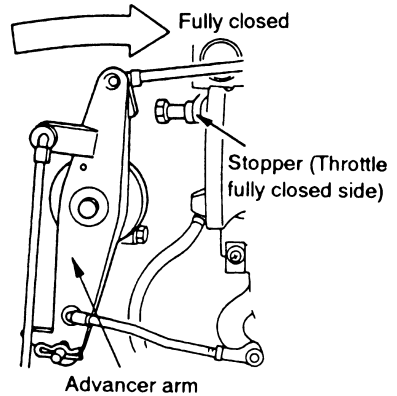
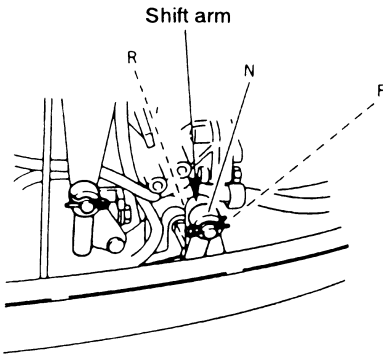

- ⑥ Adjust cable joint until the hole meets with the Advancer Arm pin. After adjustment, lock a cable joint with a nut and secure with R-shaped pin.

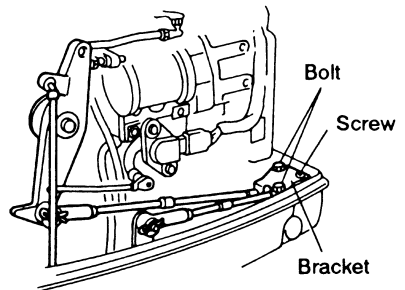
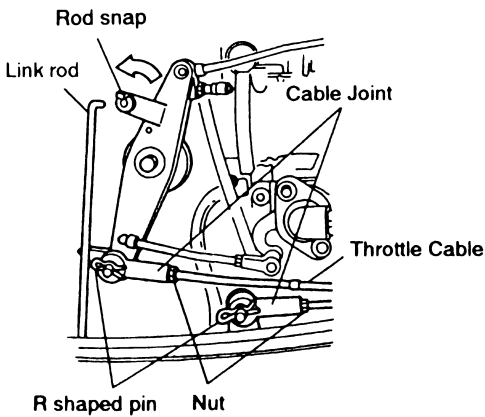

3 Connecting the Remote Control Cable to the engine.

70 · 90

- ① Detach the upper engine cover by turning the lever.

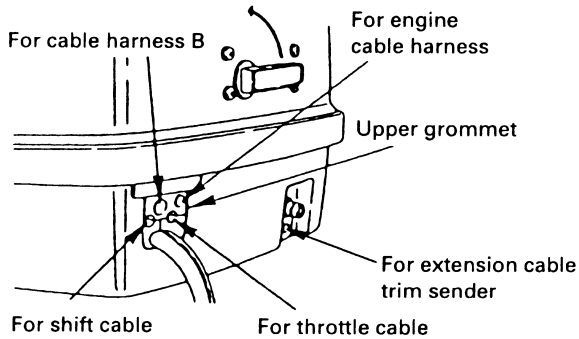

- ② Detach the upper grommet cord clamp bolt.
- ③ Detach the throttle and shift cable joints by removing the R-shaped pins.

Move the shift arm Forward, to Neutral and to Reverse to confirm the shift is working, and then set the shift arm to Neutral.

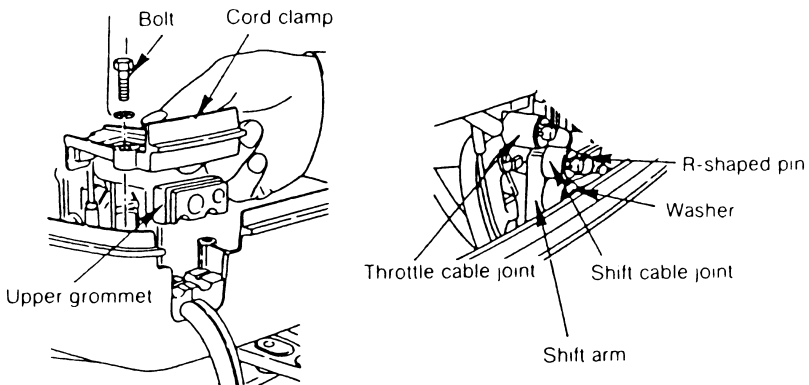

- Screw the tip of the remote control cable into the cable joint up to approx. 10 mm (0.39 inch), then lock them with a lock nut. Here, apply grease to the hole of the cable joint.

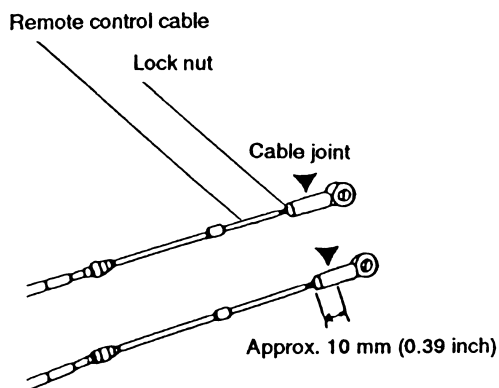

- ④ Move the Remote Control lever Forward, to Neutral and to Reverse to confirm the shift is working, and then set the lever to Neutral.

- Double-check that the Remote Control Cables, the throttle cable and shift cable have been connected correctly. Move the Remote Control Lever Forward until the first engaging point (approx. 32°). The cable which is moved first when the lever is turned is a shift cable. Check that the shift lever is in Neutral and the neutral warm-up lever is fully closed when the remote control cables have been connected.

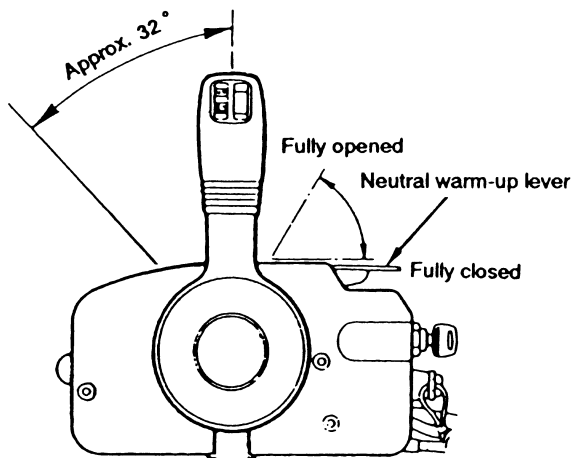

- ⑤ Set the shift arm to the [N] position and close the advancer arm completely. If the advancer arm does not contact with the stopper, the throttle position sensor will be active improperly.
- The advancer arm should have contact with the stopper at neutral position of the remote control lever.

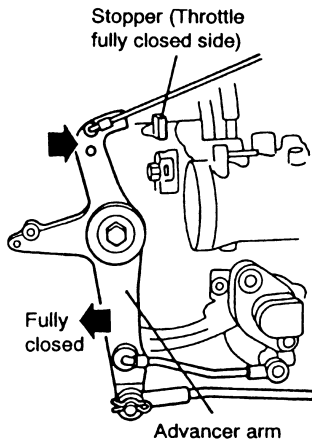

- ⑥ Adjust cable joint until the hole meets with the Advancer Arm pin. After adjustment, lock a cable joint with a nut and secure with R-shaped pin.

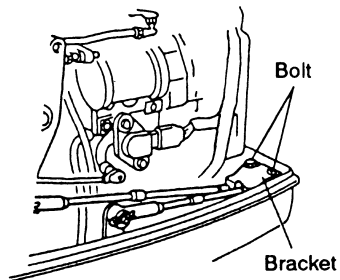
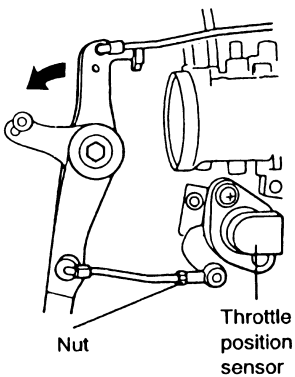

4 Connecting Cords and Cable

- ① Connect cable harness B and meter lead wire to cable harness A.

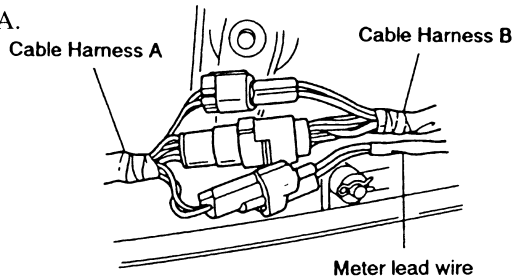

- ② Connect the trim sender and the extension cable trim sensor.

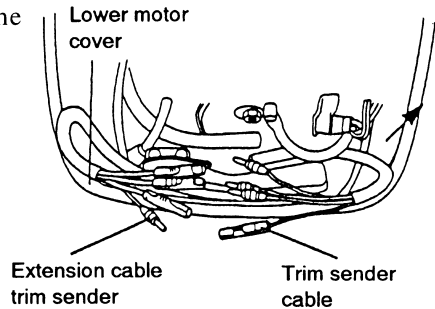

▲ CAUTION

Do not disconnect the electric couplers while the engine is running, as this will damage the C.D. unit and could result in a serious electric shock.

5 Installing the meters

Install the meters securely in the dashboard where they can be easily read and are not exposed to water splashes. The recommended dashboard thickness is 2 ~ 11mm (0.08 ~ 0.4 in.). For dashboards thicker than 11mm (0.4 in.), the fitting plate should be cut accordingly. Be sure to tighten the fitting nuts on the fitting plate evenly.

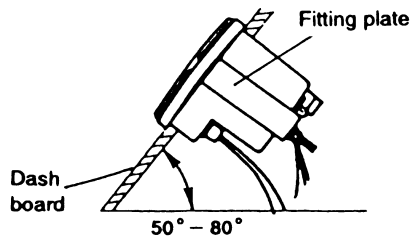

The dashboard inclination should be 50° ~ 80°

Set the tachometer selector knob to “4P”.

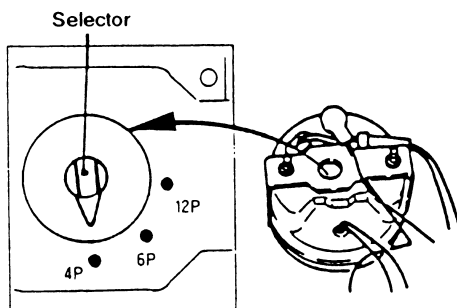

Cut holes with 85mm (3.346 in.) diameter for the tachometer and 52.5mm (2.067 in.) for the trim meter.

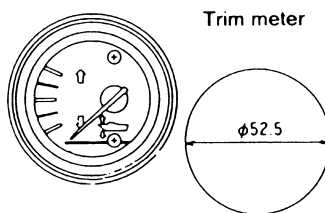
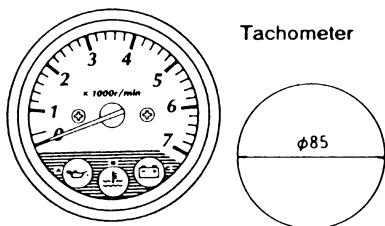

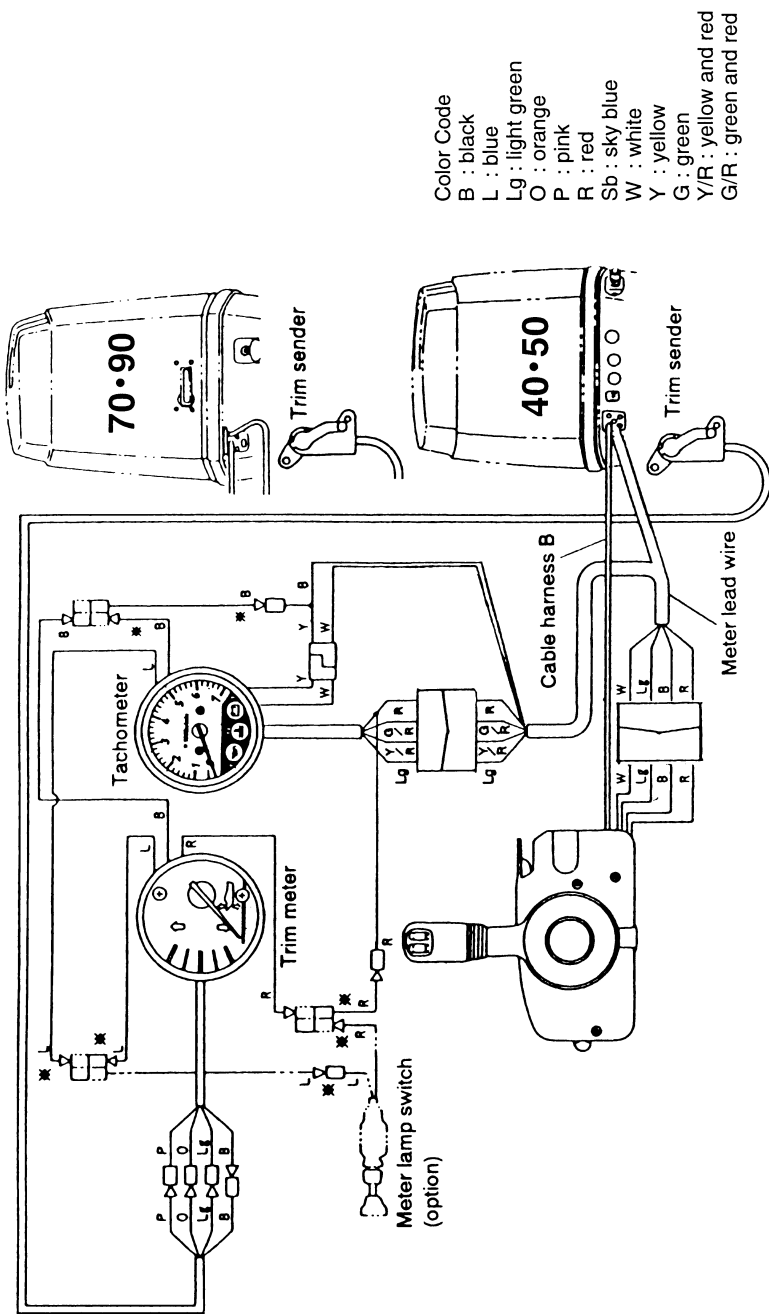

(Note)
 The parts of ※ mark is to be wired when
 a Meter Lamp Switch (option) is fixed.

6 Installing the Drag Link Assembly

Incorrect or unstable installation of the Drag Link Assembly can result in accidents while riding the boat or breakage of the hull.

Installation of the Drag Link Assembly by your dealer is highly recommended.

Note:

Depending on the steering cable manufacturer, spacers (optional) may be required.

- ① Connect the Drag Link Rod to the tip of the steering cable.
Tighten the rod using self-locking nut, making sure the rod can swing freely.
- ② Connect the other tip of the rod to the steering bracket with a bolt, applying a collar and washer. The bolt head must face downward. Secure with a split pin to the bolt.

Note:

Apply grease in required places. (Refer to the illustration below)
Apply grease inside the bracket bolt.

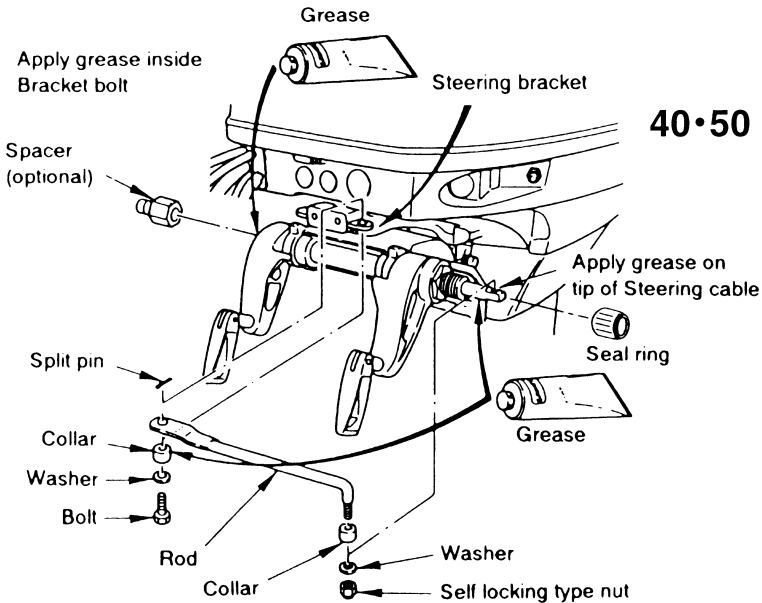

Apply grease inside the bracket bolt

70•90

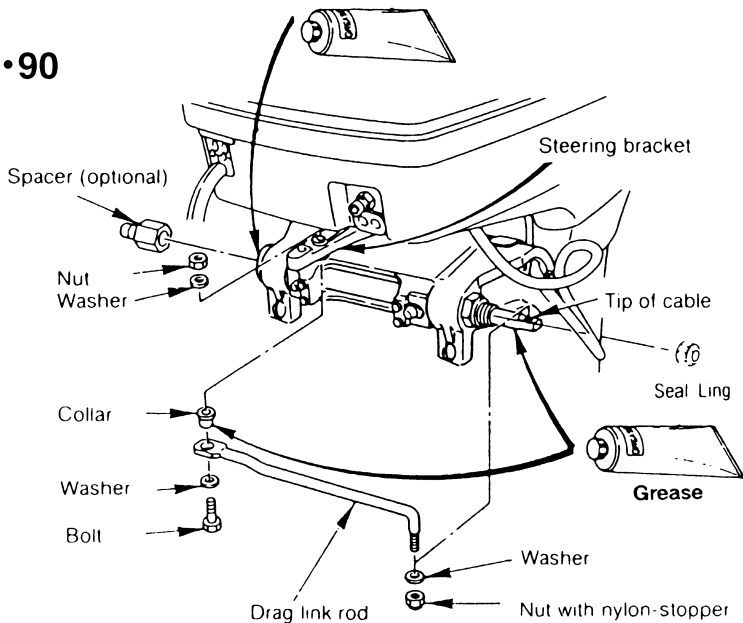

7 Battery

This engine will not start without battery.

- ① Keep the battery in the designated battery space of the boat, Secure it tightly and make sure it cannot be reached by water.
- ② Connect the positive (+) cable connector (with red tube) to the positive (+) terminal first. Then connect the negative (-) cable connector to the negative (-) terminal. When disconnecting the battery, always disconnect the negative (-) cable first.
- ③ Use a 12 V, 100 AH battery (or 12 V, 120 AH battery for cold areas).

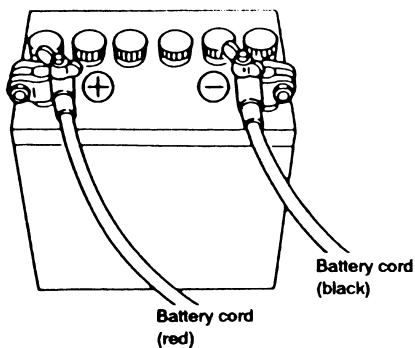

Notes:

1. Battery cables should be of sufficient length to allow free movement of the engine.
2. Keep battery cables in a tidy arrangement, and protect them from damage (from steering, etc.)
3. If the battery cable is poorly connected, it may cause a failure in starting the engine or malfunction of some electronic device.
4. The battery charging system will be damaged if the polarity (+ and -) is reversed.
5. Be sure the battery is fully charged prior to starting the engine.
6. Do not disconnect the battery cable(s) from the battery terminal(s) during engine running.

▲ WARNING

- Hydrogen gas is generated when charging a battery. Thus, keep the battery well ventilated during charging. Remove from boat, this will protect your hull interior from damage. Electric sparks, cigarette smoking and other sources of fire must be avoided in the charging area to prevent explosion of the battery.
- The battery fluid (electrolyte) contains sulfuric acid. If electrolyte is spilled on the skin, clothes, etc. wash thoroughly with water and consult a medical doctor. Always use safety glasses and rubber gloves when handling the battery.

5. FUEL & ENGINE OIL

Fuel

Unleaded, minimum pump posted 87 octane gasoline is recommended.
(Octane is based on posted rating.)
(91 based on the research octane rating method)

Note:

Use of low-quality gasoline results in a short engine life as well as starting difficulties and other engine problems.

Notes:

- (1) Gasoline containing alcohol {methanol (methyl), or ethanol (ethyl)}, acetone or benzene, may cause:
 - Wear and damage to bearings, cylinder(s), piston(s), piston rings.
 - Corrosion of metal parts.
 - Deterioration of rubber parts and plastic parts.
 - Starting, idling, and other engine performance problems.
- (2) Do not use gasoline that contains more than 10% ethanol or more than 5% methanol.
- (3) Damages resulting from the use of gasolines that contain alcohol, acetone or benzene are not covered under the limited warranty.

Fuel tank capacity- - 25 liters (6.6 U.S. gal)

Engine oil

Use a genuine engine oil or recommended one.

Will not recommend use of other two stroke engine oil.

Fuel Tank

When using a fixed fuel tank in place of genuine fuel tank, it is recommended to select a one with a structure facilitating interior cleaning.

DANGER

Gasoline vapors are present, an errant spark could cause an explosion or fire.

- Do not smoke near gasoline.
- Do not overfill gasoline.

If any gasoline is spilled, wipe it up immediately.

- Stop the engine before pouring gasoline into the fuel tank.

▲ CAUTION

DO NOT mix different brands of oil.

Mixing different brands of oil, or different types of oil even if the brand is the same, may cause gelling, resulting in possible filter screen blockage. This could result in serious engine damage because of impaired lubrication performance.

The required amount of engine oil is automatically supplied from the oil tank, through the oil pump, according to the engine running conditions. Gasoline is fed over a separate feeding line.

Replenishing oil in the engine oil tank

1. Open the filler lid of the upper engine cover.
2. Open the oil tank cap.
3. Fill up the tank with Genuine Engine Oil or recommended oil.
4. Close the oil tank cap and filler lid.

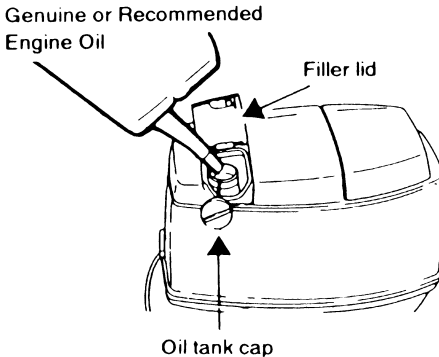

▲ CAUTION

1. In the unlikely event that gasoline by mistake is filled into the oil tank, drain the oil tank completely, and consult an authorized service shop for advice.
2. Check the amount of oil in the oil tank visually before starting the engine. Running out of oil at sea is a cause for potential disaster.

Oil pump air vent

Visually check whether there is air in the oil through the vinyl pipe connecting the oil tank with the oil pump. If present, purge the air as follows:

40 • 50

- Loosen the air vent screw on the oil pump to purge the air, and tighten it when all air, as seen through the vinyl pipe on the oil pump side, has been purged.

40•50

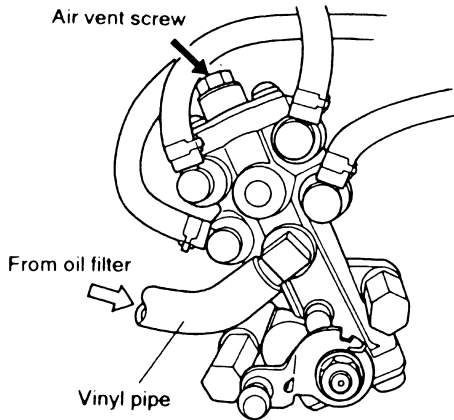

70 • 90

- See page 34 for air removal from the oil lines.

Note:

Wipe off any spilled oil with a rag, and dispose of it.

6. RUNNING

1 Break-in - - - - -10 hours

Start the break-in after reading the next section [Starting] very carefully.

Before break-in, you need 30 minutes idle running after forced engine oil feeding.

The most critical time in the life of your engine is the first 10 hours of operation. Correct operation during this break-in period will prolong the life of the engine and ensure optimum performance. Follow the procedures shown below carefully.

Time	Break-in method	Running Conditions
0 min –	Trolling or idling speed	Cruising at minimum speed
10 min –	Throttle opening < 1/2 about 3,000 rpm	–
1 hr –	Throttle opening < 3/4 about 4,000 rpm	Run with full throttle for 1min – 10 min.
2 hrs –	Throttle opening 3/4 about 4,000 rpm	Run with full throttle for short time
10 hs –	Normal running	–

CAUTION

- ① Never pour engine oil into the fuel tank.
- ② Severe engine damage may be caused if the break-in procedures described above are not observed.
- ③ Change new gear oil after 10 hours break-in.

2 Starting

▲ CAUTION

NEVER fill up portable fuel tanks on board to avoid fire or explosion resulting from spilled gasoline. If gasoline is ever spilled on board, wipe it up thoroughly. Fuel tanks must always be filled up on land.

① Preparations

(1) Loosen the air vent screw on the fuel tank cap.

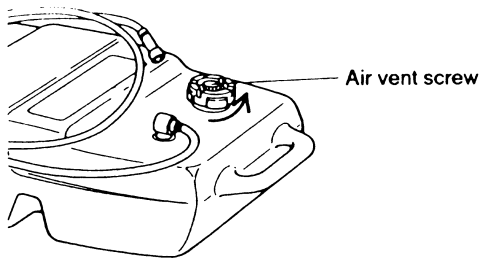

(2) Connect the fuel connector to the engine.

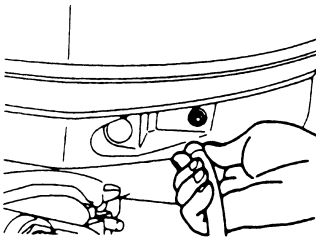

40•50

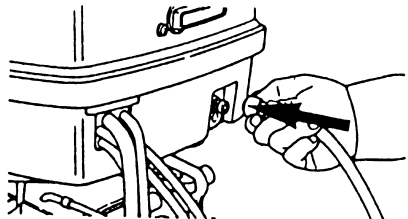

70•90

(3) Install a lock in the stop switch.

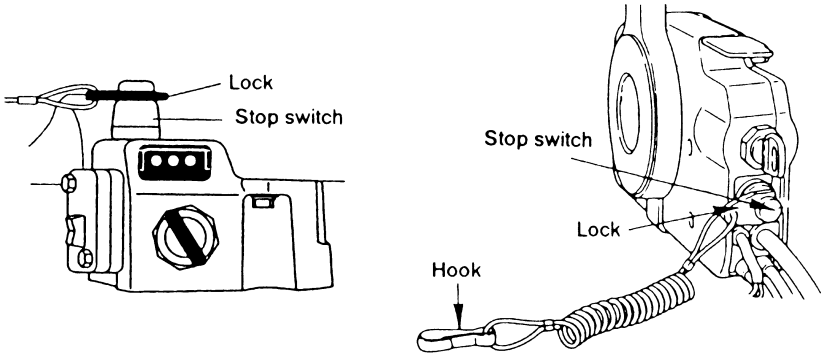

▲ CAUTION

- Be sure to connect the emergency stop line to your wrist. The engine is shut down if the stop line switch is disconnected. This is a safety measure, designed to protect the driver if thrown overboard.
- If the engine is stopped by the stop switch, immediately turn off the main switch.

(4) Feed fuel to the carburetor by squeezing the primer bulb until firm.

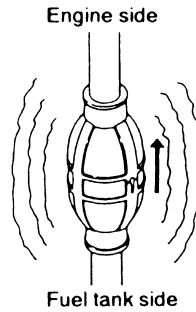

Forced fuel feeding:

When the engine is new, stops because of emptying fuel tank or have been left without operation for a long time, or just after the engine is overhauled, be sure to execute the following operation for feeding the engine with fuel forcedly before starting the engine.

- a. Repeat to squeeze the primer bulb until it becomes firm.
- b. Set the main switch to "ON" position and hold it turned on for 3 seconds.
— To actuate the FFP (Fuel Feed Pump).
- c. Turn off the main switch and again squeeze the primer bulb repeatedly until it becomes firm.
- d. Repeat the above steps b and c until the primer bulb remains as it is firm.

Forced engine oil feeding:

When the engine is new or have been left without operation for a long time, or just after the engine is overhauled, be sure to execute the following operation for forcedly feeding the engine oil to the oil line before starting the engine.

40 • 50

- Disconnect the link rod by turning the rod snap interlocking with the oil pump as shown in the figure.
- Make sure that the oil pump control lever is set at open side position.
- Idle the engine for more than 30 minutes.
- Reset the link rod to the advancer arm.

40•50

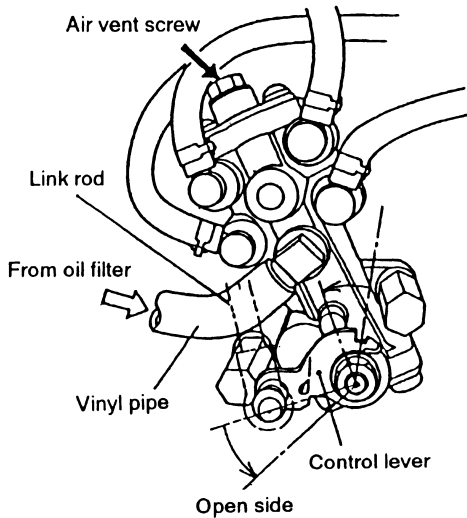
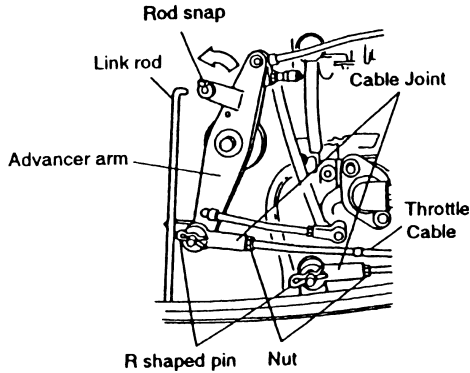

70 • 90 (Electric Oil Pump)

Follow the steps shown below to remove air from all the clear plastic oil lines ①—⑨.

<Oil Tank-Filter (①)>

- Fill up the oil tank. Place the cloth under the oil filter to receive oil coming out of oil line with air bubbles.
- Remove the oil line ① at the filter inlet (A). Receive oil coming out of the oil line with the cloth placed above.
- When the oil that does not include air comes out, reinstall the oil line ① and clip.

<Filter-Oil Pump-Cylinder Block (②—⑨)>

- Turn the key switch of remote control into “ON” position (not into “START” position).
- Within one (1) second after buzzer stops beeping, pull off the lock of lanyard stop switch.
- Within the two (2) seconds after pulling off the lock of lanyard stop switch, quickly pull the stop switch knob 2 times.
- Now buzzer sounds three (3) short beeps and electric oil pump is automatically activated for one (1) minute to remove the air remaining in the oil lines.
- Turn the key switch of remote control into “OFF” position, after the air in all the oil lines are completely removed.

70•90

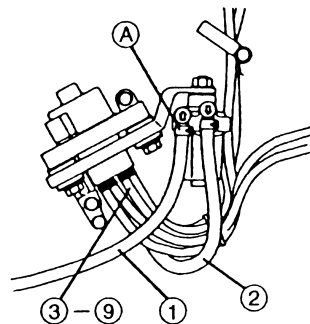
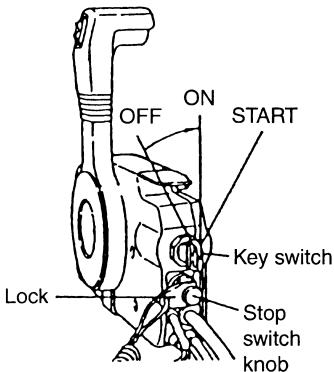

②-1. Starting **EFO • EFTO**

(1) Set the shift lever to Neutral

Note:

Be sure that the shift is at neutral when starting the engine.
This model is provided with start in-gear protection.

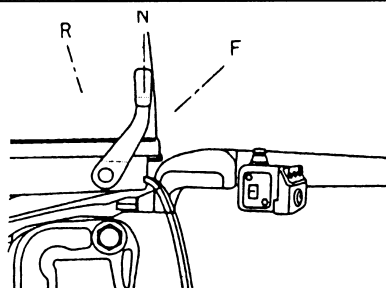

▲ CAUTION

If motor starts in gear, do not use, contact your dealer.

(2) Turn the throttle grip so that the indicator line meets the “START” mark (completely closed).

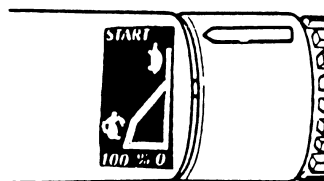

Note:

Turn the handle grip to the [START] (fully closed), before turning the main switch key to [ON].

The wrong operation i.e. turn the main switch key to [ON] on the condition that the handle grip is opened will be memorized by ECU (engine control unit).

If this wrong operation has done repeatedly, it will have a possibility that the three warning lamps flash. In this case, turn the handle grip to [START] (fully closed) and start the next operation after returning the main switch key to [OFF].

(3) Turn the main switch key to ON, and wait a few seconds until the sound of the warning buzzer stops. And then continue turning the key clockwise to start the engine.

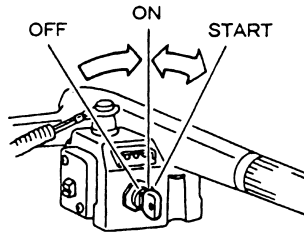

Note:

If the main switch key is pressed for 1(one) second during idling or trolling operation, the buzzer sounds and engine revolution changes. Each time the main switch key is pressed in the above manner, engine speed changes as follows.

700 → 800 → 900 → 800 → 700 → 800 → 900 rpm →

(4) Release the main switch key as soon as the engine starts. The key will return to the “ON” position automatically.

Notes:

“Important”

1. Extended operation of the starter motor will run the battery down. Operate the starter motor for a maximum of 5 seconds. If the engine does not start, wait for 10 seconds before operating the starter motor again.
2. NEVER operate the starter motor once the engine has started.
3. If the starter motor won't turn over, check that the battery terminal connections are tight and the battery is fully charged.

▲ CAUTION

Do not operate engine without ample supply of cooling water. If the cooling water supply is insufficient, damage to the cylinder wall and water pump impeller will occur.

②-2. Starting EPTO

- (1) Insert the key into the remote control box.
- (2) Set the Remote Control lever to Neutral (N).

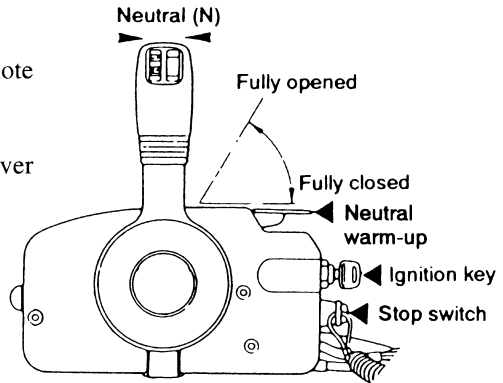

Note:

Turn the neutral warm-up lever to the fully closed position, before turning the main switch key to [ON].

The wrong operation i.e. turn the main switch key to [ON] on the condition that the lever is opened will be memorized by ECU (engine control unit).

If this wrong operation has done repeatedly, it will have a possibility that the three warning lamps flash. In this case, turn the lever to the fully closed position and start the next operation after returning the main switch key to [OFF].

- (3) Turn the main switch key to ON, and wait a few seconds until the sound of the warning buzzer stops.

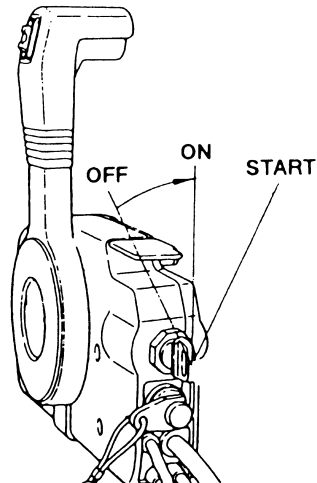

- (4) Continue turning the key clockwise to start the engine. When the engine starts, release the key and allow it to return to ON.

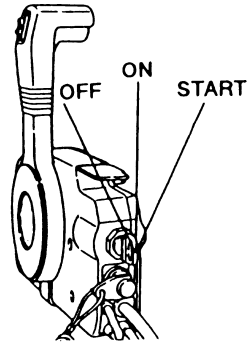

Note:

If the main switch key is pressed for 1(one) second during idling or trolling operation, the buzzer sounds and engine revolution changes. Each time the main switch key is pressed in the above manner, engine speed changes as follows.

700 → 800 → 900 → 800 → 700 → 800 → 900 rpm →

Notes:

“Important”

1. Extended operation of the starter motor will run the battery down. Operate the starter motor for a maximum of 5 seconds. If the engine does not start, wait for 10 seconds before operating the starter motor again or starter will be damaged.
2. NEVER operate the starter motor once the engine has started.
3. If the starter motor won't turn over, check that the battery terminal connections are tight and the battery is fully charged.

▲ CAUTION

Do not drive engine without ample supply of cooling water. If the cooling water supply is insufficient, damage to the cylinder wall and water pump impeller will occur.

3 Warm-up

Before driving the boat, let the engine run at low speed to let it warm and allow the oil to circulate through the engine. If the engine is not warmed up beforehand, the engine life will shorten greatly.

This outboard engine automatically controls warm-up operation, namely, it runs at a speed slightly higher than idling just after it is started, and it reverts to the normal running at a preset speed after warm-up is complete.

During the warm-up operation, confirm that cooling water is discharged from the check port and idle port.

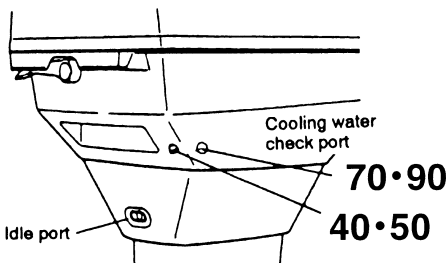
▲ CAUTION	
<p>If cooling water is not discharged and engine operation is continued, the engine will overheat and damage occur.</p>	

- Engine speed
Proper idle speed after warm-up operation

Clutch engaged (In gear)	Clutch disengaged (Out of gear)
700 rpm	700 rpm

▲ CAUTION
Do not shift to [F] or [R] until turning into proper idle speed.

Do not exceed the full-throttle engine speed

Full-throttle engine speed
5150 ~ 5850 rpm

4 Warning System

When there is something abnormal with the engine, the warning lamp flashes and/or the buzzer sounds.

If a trouble occurs, deal with it as mentioned below.

(1) ESG (A device preventing over revolution)

ESG is a device to prevent over revolution of the engine.

If the load to the engine becomes light for some reason, it runs at a higher speed than the usual. In such the case, the buzzer sounds and the ESG is activated not to ignite the spark plug, therefore, the engine speed varies.

Remedy:

Immediately turn the throttle grip or the control lever to the intermediate or lower speed and move the boat to a safe place. Then, shift the control lever or shift lever to the neutral (N) position and stop the engine.

Engine speed to activate ESG: 6,000 rpm approx.

Notes:

- | |
|--|
| <ul style="list-style-type: none">● If the propeller is damaged such as worn, broken, bent propeller blade(s) or slipping propeller rubber, replace the propeller.● If the pitch of the propeller is small and the engine runs at a high speed (rpm), replace the propeller with another proper within the full-throttle speed range. |
|--|

(2) Low oil level

If the engine oil in the oil tank decreases under the specified quantity (40 · 50 : 350ml approx. 70 · 90 : 610ml approx.) during operation, this system is warned by both the warning lamp and buzzer.

Explaining in detail, the oil level warning lamp flashes and the buzzer repeats beeping three times every 2 minutes.

Note:

This system will be warned wherever the shift lever positioned [N], [F], [R].

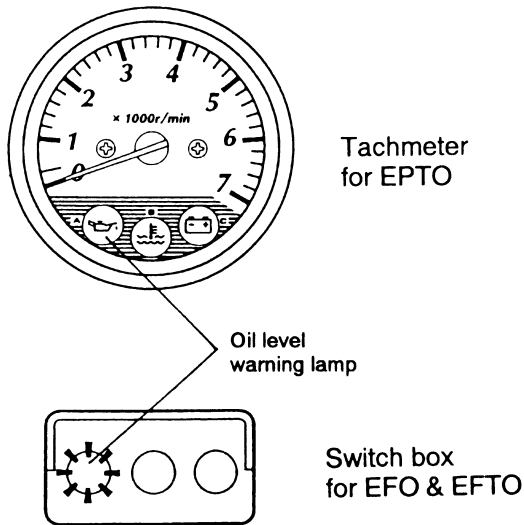

Remedy:

Slow down the engine speed and move the boat to a safe place. Then turn off the main switch and replenish the oil tank with engine oil after the engine completely stops.

After replenishment of oil is complete, start the engine and make sure that the warning lamp in the tachometer is turned off without sounding of the buzzer or the warning lamp in the switch box is turned off without sounding of the buzzer.

(3) Cooling water lacking

If the cooling water temperature for the engine exceeds the specific degree during operation, the warning lamp flashes with the buzzer sounding and the engine speed is automatically slowed down.

Note:

This warning is let out according to the sensing result of the cooling water only; without regard to sensing conditions of combustion, lubrication, etc.

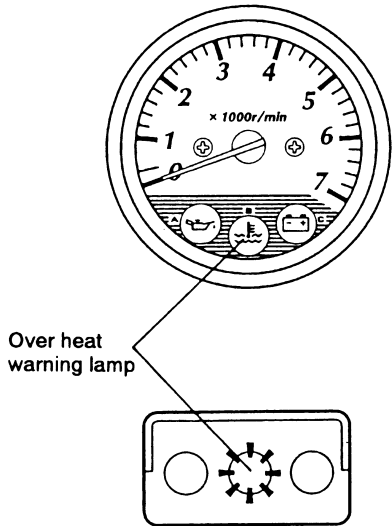

Remedy:

Move the boat to a safe place as soon as possible, and turn the throttle grip or control lever to the low speed position. Then, shift the shift lever or control lever to the neutral (N) position and stop the engine after making sure that cooling water is drained out of the cooling water check port.

If dust, vinyl, etc. are adhering to the gear case, remove them.

Sensing temperature of sensor	Controlled engine speed	Remedy ※
Limit Over limit	2,800 to 3,200 rpm 700 to 900 rpm	① Slow down to idling speed ② Stop the engine

※: This controlled engine speed will not be canceled unless the following operation ① and ② is done although the cooling water get back to normal temperature.

▲ CAUTION

If the buzzer sounds frequently after restarting the engine, please contact your dealer.

(4) Battery voltage too low

If the battery voltage drops to 10 V or lower, the warning lamp flashes. And also if the voltage is too high, all of the three warning lamps flash. If the battery is defective or the battery cable is poorly connected, the warning lamp flashes and the engine speed is automatically slowed down to 2,800 to 3,200 rpm. If the defect is serious, the engine will stop.

Remedy:

- Check the battery cable connection.
If there is a poor connection, reconnect it tightly.
- Charge the battery.
- Replace the battery with a new one.

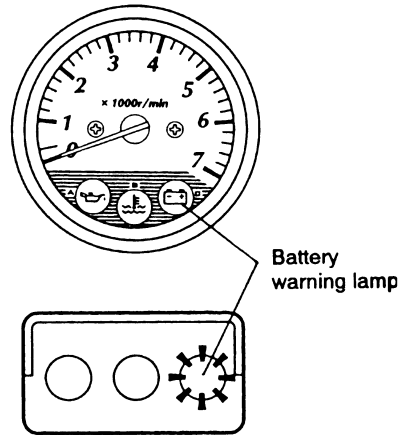

(5) Engine trouble

In case of an engine trouble, all the three warning lamps flashes at the same time.

Notes:

This warning system has three kind indications with cause of engine trouble as below.

1. The warning lamp flash
2. The engine speed control 2,800~3,200 rpm and the warning lamp flash
3. The engine speed control 700 ~900 rpm and the warning lamp flash

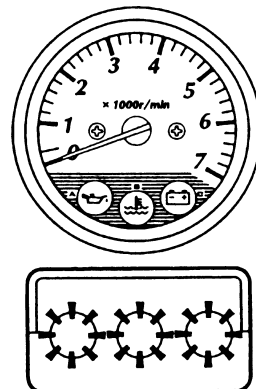

Remedy:

Consult your dealer about the trouble, because the engine needs inspection and repair service by an authorized serviceman in this case.

7. OPERATION

1 Forward/Reverse Running

(1) EFO • EFTO

Turn the throttle grip toward “SLOW” and move the Shift Lever quickly to Forward or Reverse when the engine speed has reached the lowest rpm.

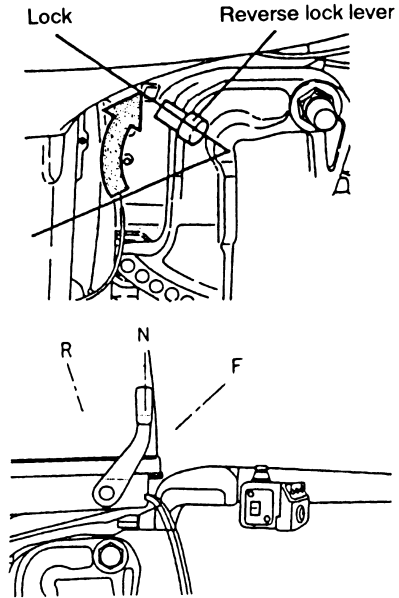

▲ CAUTION

1. It may be dangerous to attempt shifting at high RPM. Be sure to slow down to trolling or idling rpm before shifting.
2. Before moving the Shift Lever to Reverse, make sure the Reverse Lock is engaged (in up position). . . . EFO type only

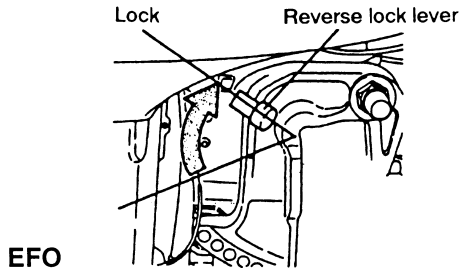

3. Do not increase the engine speed unnecessarily while reversing.
4. The Shift Lever cannot be turned from Neutral to Reverse unless the throttle grip has been turned fully toward “SLOW”.

2 Shallow water running

▲ CAUTION

- When in shallow water running, take care that the water strainer is submerged at all times and that water is continuously running out of the cooling water check port.
- Be sure to run slowly when using the shallow water drive. Running at higher speeds will result in lack of control and may cause damage to the gear case.
- Make sure that the motor does not strike the bottom, especially when running in **REVERSE**. If the motor strikes the bottom while reversing, the impact is transmitted to the transom, risking damage to both the motor and the boat.

(1) **EFO**

- ① Set the Reverse Lock Lever provided on the starboard side to “Release” by turning it downward.

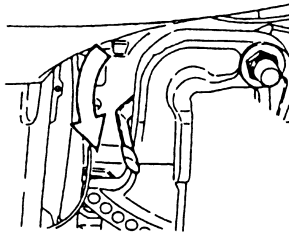

-
- ② Tilt the engine up approx. 45° and lower it. The engine will now be set to the shallow water setting.

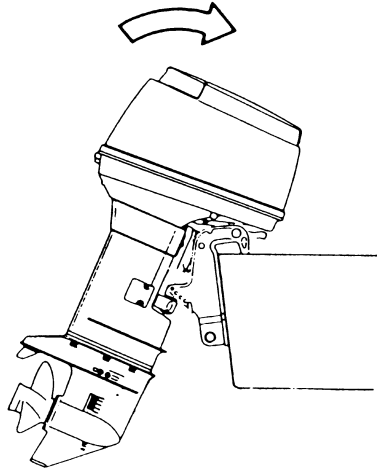

- ③ Releasing the shallow water setting
- Turn the Reverse Lock Lever upward to set them in “LOCK” position.
 - Tilt up the engine slightly and then let it go down. The shallow water setting is then released.
 - The engine is released from shallow water setting, and locked at normal running position.

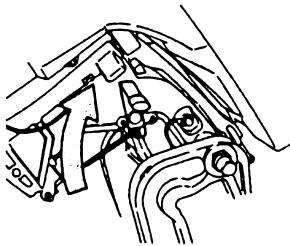

(2) **EFTO • EPTO**

Tilt up the engine using the Power Trim & Tilt system.

3 Stopping the engine

▲ CAUTION

NEVER stop the engine immediately after a full throttle run. Keep it running for two or three minutes at idling speed (Shift Lever set to Neutral) to allow it to cool down.

(1) **EFO • EFTO**

- ① Reduce the engine speed to idling rpm.
- ② Turn the Main Switch to “OFF”. The engine will then stop.

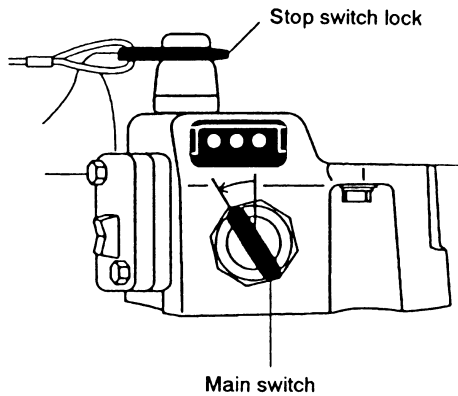

(2) **EPTO**

- ① Move the Remote Control lever to Neutral and let the engine idle for 2 – 3 minutes to allow it to cool down.

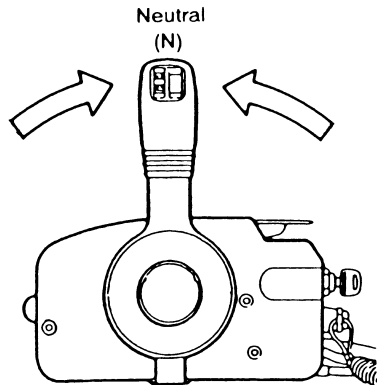

- ② Turn the main switch key counter-clockwise. The engine will stop.

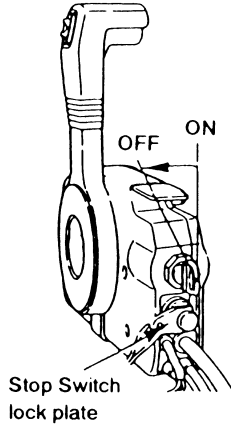

EFO • EFTO • EPTO

Note:
After the engine has stopped:
Disconnect the cables from the battery if the engine will not be used for an extended period of time.

- ③ Disconnect the fuel connector from the engine.

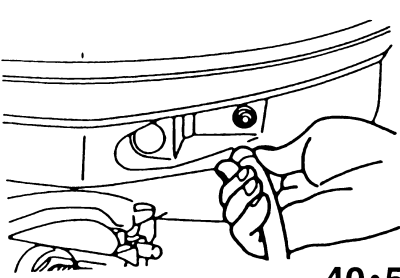

40•50

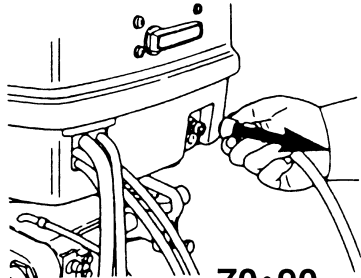

70•90

- ④ Close the air vent screw on the fuel tank cap.

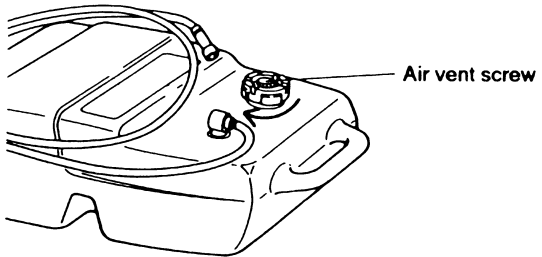

8. TRIM ADJUSTMENT

The following instructions explain how to set the best trim angle of the boat.

1 EFO

The trim angle is adjusted by setting the thrust rod in the correct thrust rod hole.

■ Proper Trim Angle

The trim angle is optimum when the boat is parallel to the water surface while running.

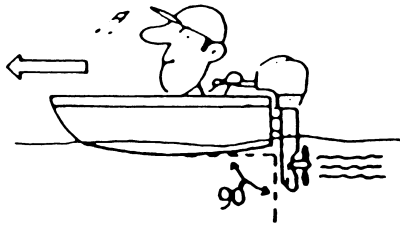

■ Improper Trim Angle (bow rises too high)

If the trim angle is excessive, the bow will rise out of the water and the speed will decrease.

Furthermore, the bow may sway or the bottom may slam the water while cruising.



In this case, decrease the trim angle by setting the thrust rod in a lower hole.

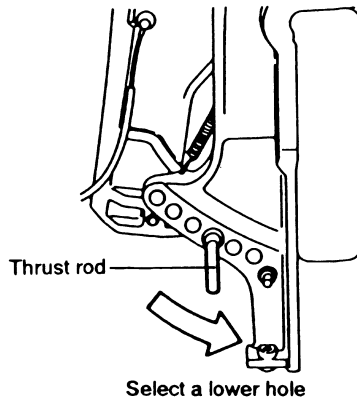

■ Improper Trim Angle (bow dips into the water)

If the trim angle is too small, the bow will dip into water, the speed will decrease, and water may enter the boat.

In this case, the trim angle should be increased by setting the thrust rod in a higher hole.

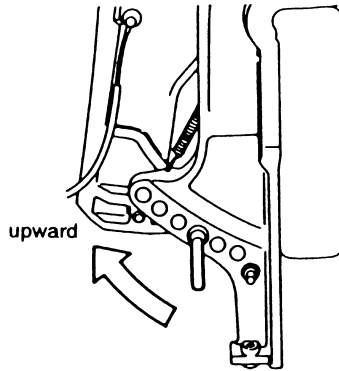

Select a higher hole

2 EFTO • EPTO

The provided Power Trim & Tilt can be adjusted to set the desired trim angle of the engine in relation to the transom shape, planing speeds and load. It is imperative that the trim angle is adjusted correctly. Incorrect adjustment will cause the boat to sway, deteriorate engine performance and may cause unsafe steering conditions.

▲ CAUTION

The Power Trim & Tilt can be set to any trim angle, however, avoid cruising with the engine tilted in the tilt range. Operating the boat in this manner, the engine may ingest air into the water cooling system, resulting in engine overheating.

- How to use the trim meter:
 When the trim angle is set as desired, take a reading off the trim meter, and record it for future reference.

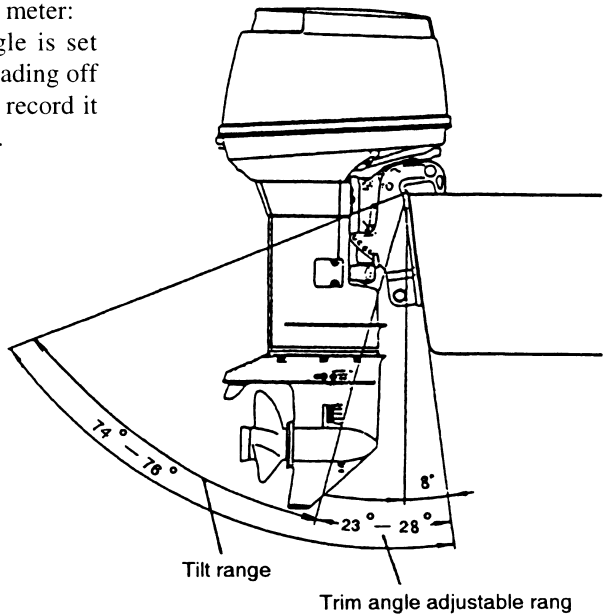

- Improper Trim Angle (bow rises too high)**

If the trim angle is excessive, the bow will rise out of the water and the speed will decrease.

Furthermore, the bow may sway or the bottom may slam the water while cruising.

In this case, decrease the trim angle by pressing the switch on the Remote Control Level to “DN”.

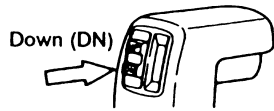

■ Improper Trim Angle (bow dips into the water)

If the trim angle is too small, the bow will dip into the water, the speed will decrease, and water may enter the boat. In this case, the trim angle should be increased by pressing the switch on the Remote Control Lever to “UP”.

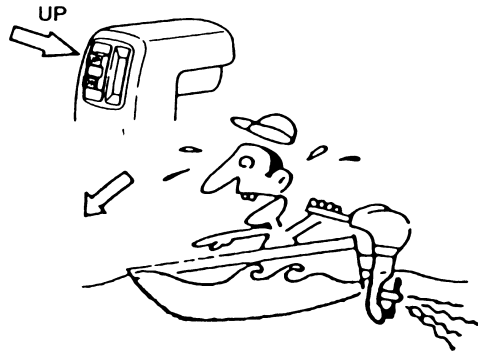

■ Proper Trim Angle

The trim angle is optimum when the boat is parallel to the water surface while running.

9. MOORING WITH THE ENGINE TILTED UP

When the engine has been stopped and it will not be used for a long time or when mooring in shallow water, tilt the engine up to prevent damage to the propeller and gear case.

(1) EFO

- ① Disconnect the fuel connector from the engine.

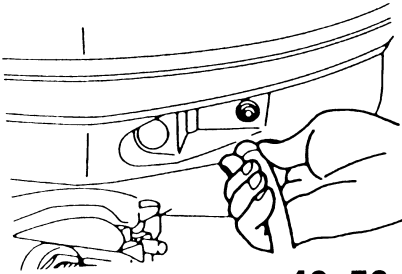

40•50

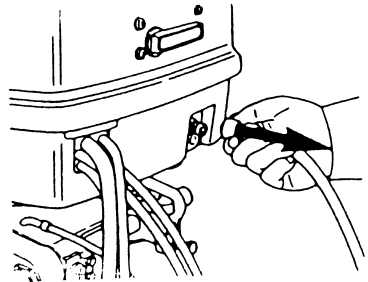

70•90

- ② Set the Reverse Lock Lever on the starboard side to “RELEASE” by turning it downward.

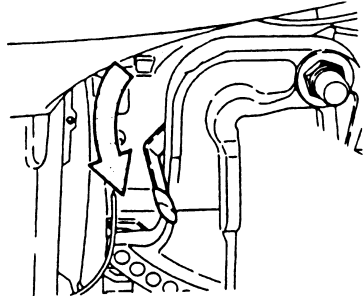

▲ WARNING

Tilt Up or Down

When tilting up or down, your finger or hand is not placed in between the swivel bracket and stern bracket.

Be sure to tilt down the outboard slowly.

-
- ③ Tilt the engine up entirely.
The tilt will lock in the
raised position.

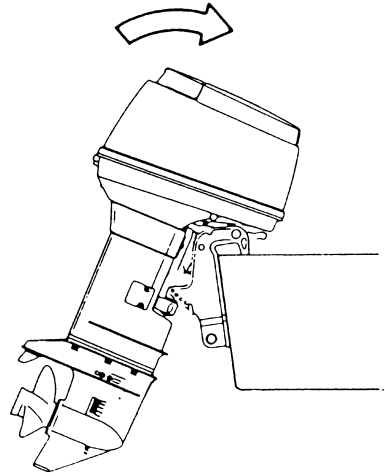

- ④ To tilt the engine down. Turn
the Reverse Lock Lever
upward (toward “LOCK”).
Tilt the engine up slightly
and then let it go down. (The
Reverse Lock will be set
automatically.)

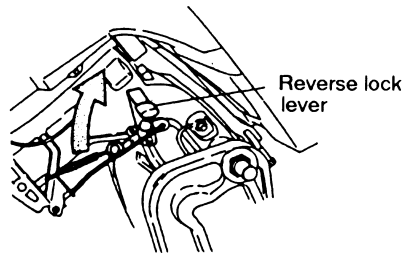

(2) **EFTO • EPTO**

- ① Disconnect the fuel connector from the engine.

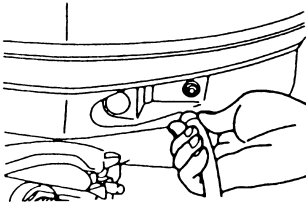

40•50

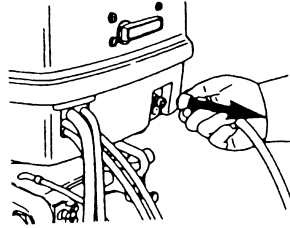

70•90

- ② Operate the Power Trim & Tilt switch and tilt the engine up. (The Main Switch must be "ON".)

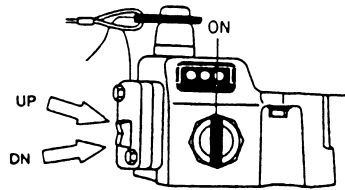
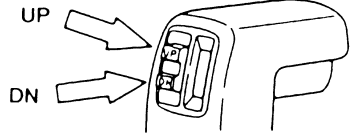

The engine can also be tilted up using the switch provided under the Lower Engine Cover. (The Main Switch need not be turned "ON" in this case.)

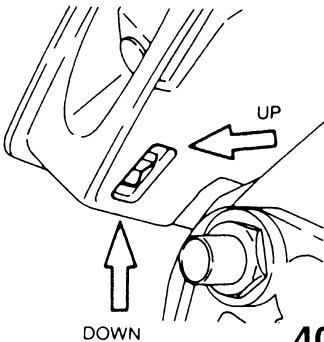

40•50

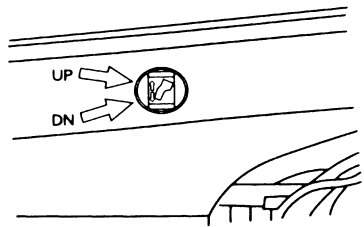

70•90

- ③ Lock the tilt with the Tilt stopper after the engine has been tilted up.

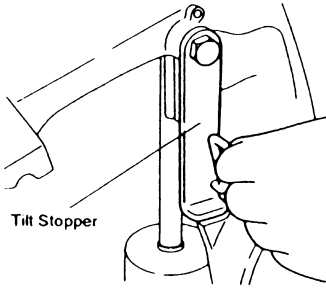

40•50

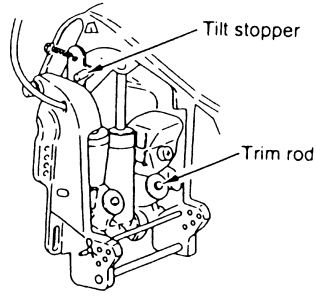

70•90

- ④ Manual tilting

If the battery is dead, and the Power Trim & Tilt Switch thus inoperative, turn the manual valve a few turns in the Manual direction. This will allow manual tilting of the engine.

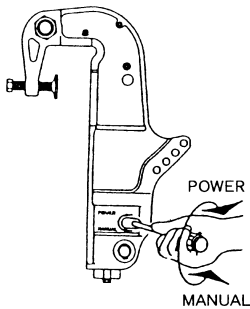

40•50

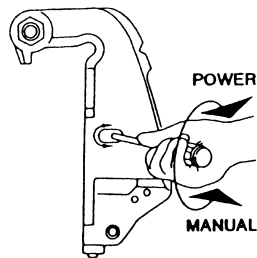

70•90

10. REMOVING AND CARRYING THE MOTOR

(1) Removing the motor

- ① Stop the engine.
- ② Disconnect the fuel connector, the remote control cable, the battery cords, bracket fixing bolts and nuts etc.
- ③ Remove the motor from the hull and completely drain the water from the gear case.

(2) Carrying the motor

Be sure to keep the engine vertical whenever you carry the motor.

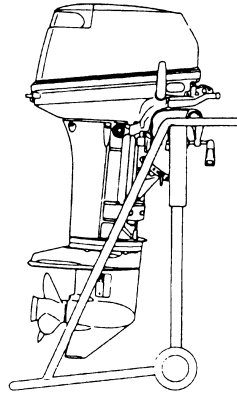

● EFTO • EPTO

When carrying or putting the engine up for storage, make sure the side with the electric motor of the Power Trim and Tilt is down otherwise air will enter the pump system for the Power Trim and Tilt operation.

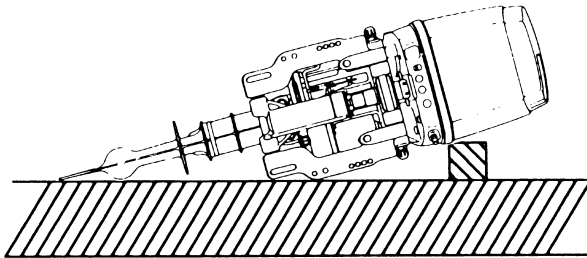

● EFO

Lay the engine with the shift lever up.

(3) Storing the motor

Keep the motor in a vertical position when you store it.

Note:

If you store the motor in a horizontal position, lay the motor as shown in figure of last page.

EFO

▲ WARNING

When taking the motor from package or removing the motor from the boat, never release the reverse lock lever. If the reverse lock lever is released, it will be very easy the stern bracket to spring up to the tilting direction because it is not fixed.

- * Tie the stern bracket to the outboard with a rope.
- * Pay attention to the tilting direction not to be injured by the springing stern bracket.

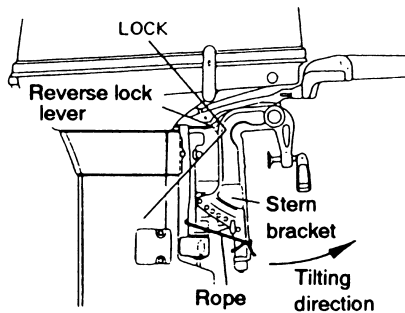

(4) Trailing

▲ CAUTION

When trailing the engine should be in a vertical (normal running) position, fully down. Trailing in the tilted position may cause damage to the motor, boat, etc.

If trailing with engine fully down is not available (the gear case skeg is too close to the road in a vertical position), fix the motor securely using a device (like a transom saver bar) in the tilted position.

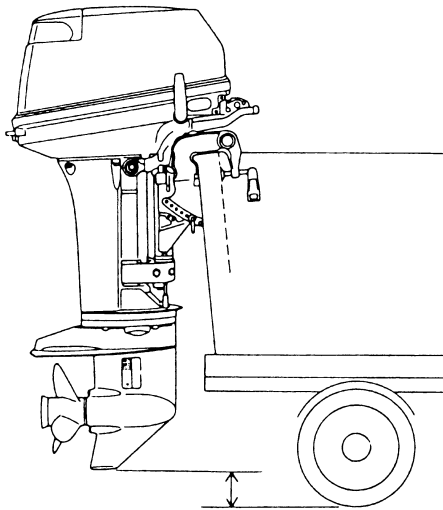

▲ CAUTION

The tilt support device supplied on your outboard is not intended for trailing. It is intended to support the engine while the boat is docked, beached, etc.

11. ADJUSTMENT

1 Remote Control Lever Load (EPTO only)

(Throttle friction adjustment screw)

To adjust the load of the Remote Control Lever, turn the throttle friction adjustment screw on the front of the Remote Control Box. Turn clockwise to increase the load and counter-clockwise to decrease it.

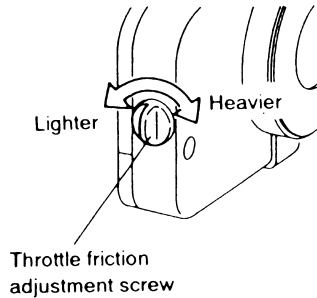

2 Trim Tab Adjustment

If straight-line cruising can not be achieved, adjust the trim tab located under the anti-ventilation plate.

- If the boat veers toward the right, direct the trim tab towards A.
- If the boat veers toward the left, direct the trim tab towards B.

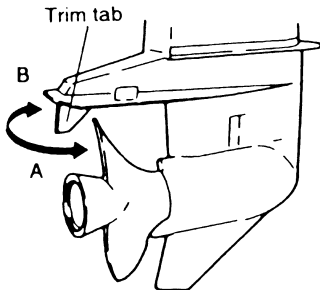

Notes:

1. The trim tab also acts as an anode to prevent electrolytic corrosion. Therefore do not paint or grease this part.
2. After adjustment securely tighten the trim tab fixing bolt.
3. Check for looseness of the bolt and the trim tab at regular intervals. Due to corrosion, the trim tab will wear down over time.

3 Steering Load Adjustment (40 • 50)

Steering load can be adjusted by turning the steering adjust bolt on the Swivel Bracket.

Turn clockwise to increase the load

Turn counter-clockwise to decrease the load

EFO

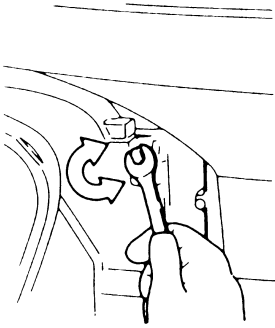

EFTO • EPTO

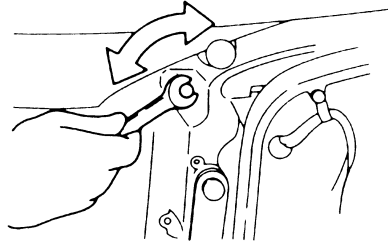

4 Throttle Grip Turning Load Adjustment (EFO • EFTO)

Turn the friction adjustment screw on the steering handle to adjust the turning load of the throttle grip.

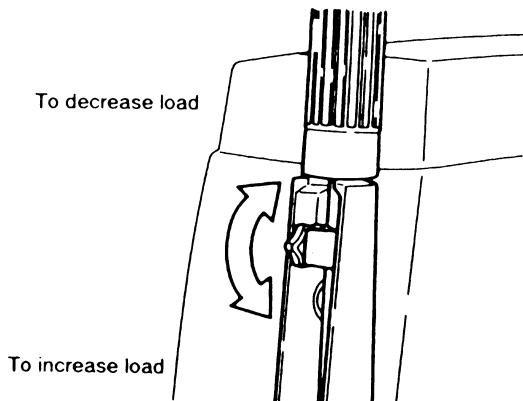

12. INSPECTION AND MAINTENANCE

Care of your outboard motor

To keep your motor in the best operating condition, it is very important that you perform daily, and periodic, maintenance as suggested in the maintenance schedules that follow.

CAUTION

- Your personal safety and that of your passengers depends on how well you maintain your outboard motor. Carefully observe all of the inspection and maintenance procedures described in this section.
- The maintenance intervals shown in the checklist apply to an outboard motor in normal use. If you use your outboard motor under severe conditions such as frequent full-throttle operation or frequent operation in brackish water, maintenance should be performed at shorter intervals. If in doubt, consult your dealer for advice.
- We strongly recommend that you use only genuine replacement parts on your outboard motor. Damage to your outboard arising from the use of other than genuine parts is not covered under the warranty.

EPA Emissions Regulations

EPA (United States Environmental Protection Agency) has emission regulations and is controlling air pollution from new outboard motors. All new motors manufactured by us are certified to EPA as conforming to the requirements of the regulations. This certification is depend upon factory standards. Therefore, factory specifications must be followed when servicing emission related controls, or making adjustments.

Maintenance, replacement, or repair of the emission control devices and systems may be performed by any marine SI (Spark Ignition) engine repair establishment or individual.

1 Daily Inspection

Perform the following checks and inspection before and after use.

Item	Points to Check	Action
Fuel System	<ul style="list-style-type: none"> ● Check the amount of fuel in the tank. ● Check for dust or water in the fuel filter. ● Check rubber pipes for oil leakage 	Replenish Clean Replace
Lubrication System	<ul style="list-style-type: none"> ● Check the amount of engine oil in the oil tank. ● Check for dust or water in the oil filter. 	Replenish Clean
Electrical Equipment	<ul style="list-style-type: none"> ● Check the spark plugs for dirt, wear and carbon built-up. Spark plugs NGK PZFR6H (0.8 mm gap) (0.0315 in) ● Check if the main switch functions normally. ● Check if the battery electrolyte level and specific gravity are normal. ● Check for loose connections on battery terminal. ● Check if the stop switch functions normally and make sure the lock plate is present. ● Check cords for loose connections and damage. 	Clean or replace Remedy or replace Replenish or recharge Retighten Remedy or replace Correct or replace
Throttle System	<ul style="list-style-type: none"> ● Check if the magneto works normally when turning the throttle grip, and also check links for looseness. 	Correct
Clutch and Propeller System	<ul style="list-style-type: none"> ● Check if the clutch engages correctly when operating the Remote Control. (or Shift lever) ● Check the propeller for bent or damaged blades. ● Check if the propeller nut is tightened and the split pin is present. 	Adjust Replace
Installation of Motor	<ul style="list-style-type: none"> ● Check all the motor installation bolts with the boat. ● Check the thrust rod installation. 	Tighten Tighten
Power Trim &Tilt	<ul style="list-style-type: none"> ● Check working of the tilt up and down of the motor. 	

Item	Points to Check	Action
Cooling Water	<ul style="list-style-type: none"> ● Check that cooling water is discharged from the cooling water check port after the engine has started. 	
Tools and Spares	<ul style="list-style-type: none"> ● To be prepare tools and spare parts for replacing spark plugs, propeller, etc. ● Check if the spare rope is provided. 	
Steering Devices	<ul style="list-style-type: none"> ● Check working of steering handle and remote control. 	
Other Parts	<ul style="list-style-type: none"> ● Check if the anode and trim tab are securely installed. ● Check the anode and trim tab for corrosion and deformation. 	Repair if necessary Replace

① Washing with fresh water

When the engine has been used in salt water or polluted water, wash the exterior and flush the cooling passage with fresh water using the flushing attachment.

Screw the included flushing attachment into the wash hole on the gear case. Connect a water hose to the flushing attachment and flush out with water. (Be sure to secure the water strainer and sub-water strainer on the gear case beforehand.)

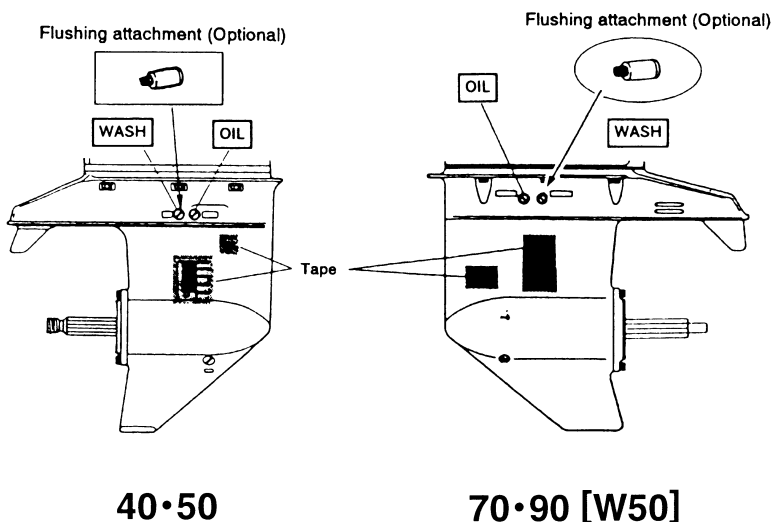

▲ WARNING

To prevent rotation of the propeller, remove it before flushing the passage.

Wash the engine before long-term storage.

Run the engine at low speed with the Remote Control lever (or Shift lever) set to Neutral to flush out fresh water from the cooling system and in the process remove salt, mud and other foreign particles.

Note:

Run the engine at low speed when flushing the cooling system.

② Replacing the propeller

A worn or bent propeller will affect engine performance and may cause engine trouble.

1. Pull out the split pin and remove the propeller nut and washer.
2. Remove the propeller by pulling toward you.
3. Apply genuine grease to the propeller shaft before mounting the new propeller.
4. Fit the washer, securely tighten the nut and insert the split pin.

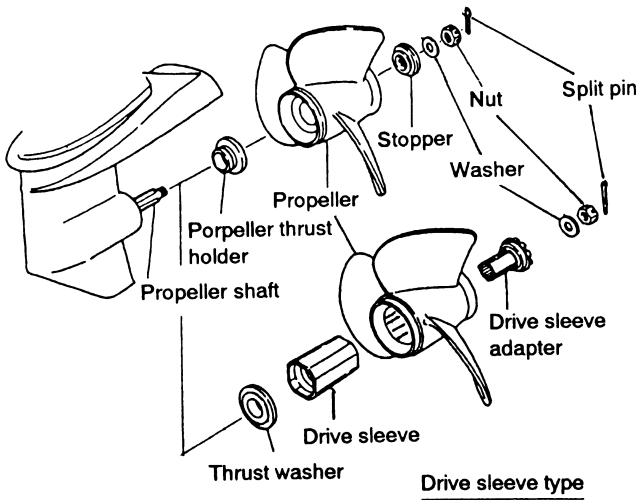

▲ CAUTION

Before removing the propeller, remove the spark plug caps from the spark plugs for your safety.

③ Replacing the spark plugs

1. Remove the upper engine cover.
2. Remove the spark plugs by turning counter-clockwise with the socket wrench (16mm: 5/8 in) fitted with the handle. Tap lightly on the spark plugs if they are hard to turn.

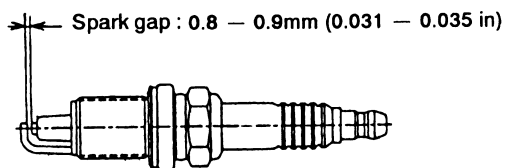

▲ CAUTION

Do not touch the high tension cords running from the ignition coil to the spark plugs while the engine is running or is turned by the electric starter motor, not even for testing the high tension cords or the spark plugs.

The high tension cords and the spark plugs generate very high electric voltage, which can cause a serious electric shock if touched.

2 Periodic Inspection

It is important to inspect and maintain your outboard motor regularly. At each interval on the chart below, be sure to perform the indicated servicing. Maintenance intervals should be determined according to the number of hours or number of months, whichever comes first.

For periodic inspection and maintenance, consult your servicing dealer.

Note:

Your outboard motor should receive careful, and complete inspection at 300 hours. This is the best time for major maintenance procedures to be carried out.

Item		Servicing Interval					Action	Remarks
		10 hours or 1 month	50 hours or 3 months	Every 100 hours or 6 months	Every 150 hours or 1 year	Every 200 hours or 2 years		
Fuel System · Compression System	Fuel filter		○	○	○	Replace	Check and clean.	For high-pressure
	Piping		○	○	○	Replace	Check and clean.	
	Fuel tank		○	○	○	○	Clean	Including filter
	Air filter			○		Replace		
	Drive belt			○		Replace		
	Fuel pressure			○		○		
	Air pressure			○		○		
Ignition	Spark plugs		○	○	○	○	Check gaps. Remove carbon deposits.	
Starting System	Starter motor		○	○	○	○	Check for salt deposits and battery cable condition.	
	Battery	○	○	○	○	○	Installation, fluid quantity, gravity	

Item		Servicing Interval					Action	Remarks
		10 hours or 1 month	50 hours or 3 months	Every 100 hours or 6 months	Every 150 hours or 1 year	Every 200 hours or 2 years		
Lower Unit	Propeller	○	○	○	○	○	Bend of blades damage, wear	
	Gear oil	Change	○	○	○	○	Change of oil or replenishment and water leak	
	Water pump		○	○	Replace	○	Check for Wear or damage	Replace impeller every 12 months
Bolt and Nuts		○	○	○	○	○	Retighten	
Sliding and Rotating Parts. Grease Nipples			○	○	○	○	Apply and pump in grease.	
Power Trim & Tilt		○		○	○	○	Check power unit oil level and refill. Check function of manual release valve.	
Engine Oil System	Oil tank						Check for leakage, damage, position of clips, and filter conditions.	Repair or replace
	Oil pipe	○		○	○	○		
	Oil filter							
Warning System			○	○	○	○		
Anode			○	○	○	○	Check corrosion and deformation	Replace

1) Changing Gear Oil

- ① Remove the oil plugs (upper and lower), and drain the gear oil completely.

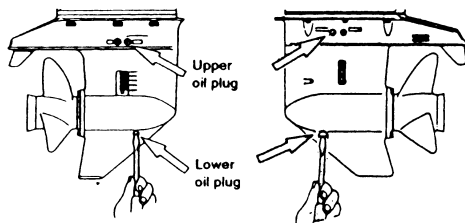

40·50

70·90 [W50]

- ② Insert the oil tube nozzle into the lower oil plug hole, and squeeze the tube until the oil flows out of the upper plug hole.

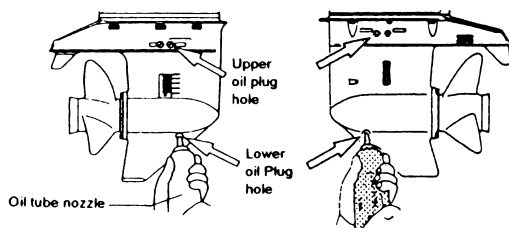

- ③ Install the upper oil plug. Then remove the oil tube nozzle and install the lower oil plug.

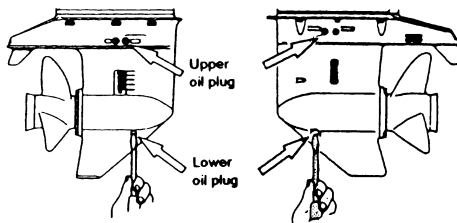

Note:

Use only genuine or recommended gear oil or, if not available, an API (American Petroleum Institute) oil grade of GL5 SAE #80 ~ SAE #90.

Required volume: 40 · 50 approx. 500mL (16.89 U.S. fluid oz)

: W50 approx. 700mL (23.65 U.S. fluid oz)

: 70 · 90 approx. 900mL (30.40 U.S. fluid oz)

2) Cleaning Tanks and Filters

- ① Fuel filters are provided inside the fuel tank and on the engine.

Loosen a Fuel Pick-up Elbow and remove it.
Then clean the Fuel Filter

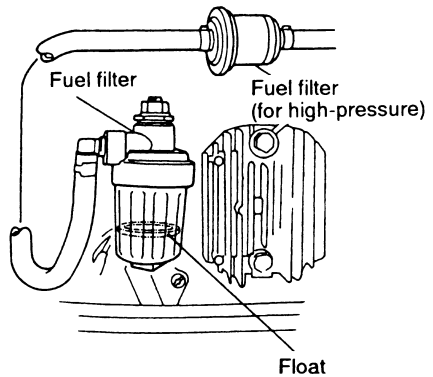
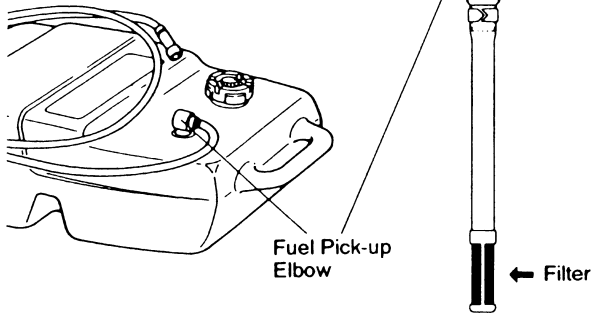

Cleaning Fuel Tank

Water or dirt in the fuel tank may cause engine trouble.

Clean the tank at specified times or after long time storage (over three months).

Clean the filters on the engine after removing the fuel filter cases.

If the red float is floating in the fuel filter, water is present. In such the case, immediately remove the cup and drain out the water.

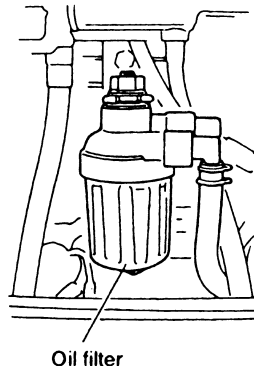

-
- ② Oil filter and oil tank. Check the oil tank and/or filter for entrapped water and dust.
1. Disconnect all pipes between the oil tank and oil pump.
 2. Clean out foreign matter.
 3. Refit the pipes to the oil tank and pumps, and then fill up with new engine oil
 4. For air purging, refer to Item No. 5 Fuel and Engine Oil.

3) Checking and Refilling Oil in the Power Trim & Tilt.

- ① Check the oil level of the reservoir tank as shown on the right while the tank is kept in a vertical position. Tilt the engine up to check the oil level in the tank.
- Remove the oil cap by turning counter-clockwise, then check if the oil level reaches the bottom line of the plug hole.

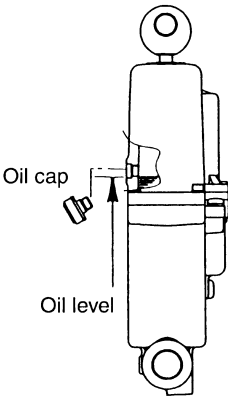

40•50

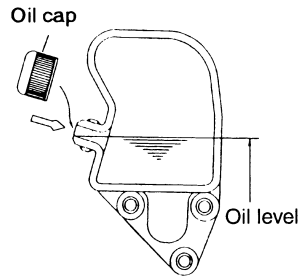

70•90

▲ CAUTION

Do not fully unscrew the oil plug with the engine tilted down. Pressurized oil in the oil tank may spurt out.

② Recommended oil

Use an automatic transmission fluid approved by GM.
Recommended oils are as shown below.

TYPE

F

FA

Dexron II

Dexron III

③ Air purging from the Power Trim and Tilt unit.

Entrapped air in the Power Trim & Tilt unit will cause poor tilting movement. With the engine mounted on the boat, set the manual release valve to the Manual side, and tilt the engine manually up/down 5–6 times while checking the oil level. When done, close the valve by turning it clockwise towards the Power side.

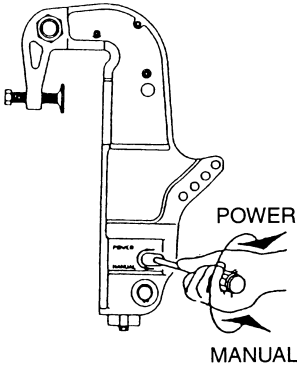

40•50

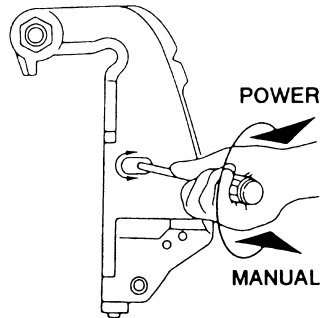

70•90

13. OFF-SEASON STORAGE

⚠ WARNING

1. When the motor is out of the water, being transported, or in storage, always remove the negative (–) battery cable to prevent accidental starting of the engine. Accidental starting when the motor is out of the water will cause water pump failure, overheating and damage to the engine due to a lack of cooling water.
2. Remove all spark plug connectors from the spark plugs when servicing the engine or propeller.

When your outboard motor is in storage, this is a good opportunity to have it serviced or overhauled by your dealer.

1 Engine

- ① Wash the engine exterior and flush the cooling water system thoroughly with fresh water. Let the water drain completely.
Wipe off any surface water with an oily rag.
- ② Drain the fuel out of the fuel tank and clean the inside of the tank and fuel filter.
- ③ Clean the engine fuel filter.
- ④ Clean the oil filter.
- ⑤ Remove the spark plugs and feed genuine Engine Oil or storage fogging oil through the spark plug holes.
Turn the engine over several times while feeding the oil into it and make sure it is evenly distributed.
- ⑥ Apply grease to the propeller shaft.
- ⑦ Change the gear oil in the gear case.
- ⑧ Apply grease to all sliding parts, joints, nuts and bolts.
- ⑨ Use a dry cloth to completely wipe off water and salt from the electrical components.
- ⑩ Stand the engine vertically in a dry place.

2 Battery

- ① Disconnect the battery cables.
- ② Clean the exterior of the battery with fresh water or compressed air. Wipe off any chemical deposits, dirt and grease from the battery.
- ③ Apply grease to the battery terminals.
- ④ Charge the battery completely before storing it for the winter.
- ⑤ Recharge the battery once a month to prevent it from discharging and the electrolyte from deteriorating.
- ⑥ Store the battery in a dry place with its cover attached.

▲ CAUTION

1. Do not allow the battery to discharge, since it can be damaged by freezing.
2. When storing your outboard for the winter, open up all the water drain holes in the gear case to permit any remaining water to drain out. If a speedometer is installed, disconnect the pickup tube and allow it to drain, then reconnect it after draining. Trapped water may crack the gear case or water pump case as a result of expansion when frozen. Check and replenish the gear case with case specified Gear Oil before storing the motor, to avoid water leakage into the gear case due to a loose lubricant vent plug or grease fill plug. Inspect the gaskets under the lubricant vent and grease plugs, replace them if necessary, and reinstall the plugs.

3 Electric Starter Motor

Coat the pinion gear and shaft of the electric starter motor with grease.

14. PRE-SEASON CHECK

Have your dealer check the engine before the season starts, or if you prefer, be sure to check the following items yourself:

- ① Check the electrolyte level, and measure the voltage and specific gravity of the battery.

Specific Gravity at 20°C	Terminal Voltage (V)	Charge Condition
1.120	10.5	Fully discharged
1.160	11.1	1/4 charged
1.210	11.7	1/2 charged
1.250	12.0	3/4 charged
1.280	13.2	Fully charged

- ② Check that the battery is secure and the battery cables installed properly.
- ③ Clean the engine oil filter.
- ④ Purge air in the vinyl pipe connecting the oil tank to the oil pump.
- ⑤ Check that the shift and throttle function properly.
(Be sure to turn the propeller shaft when checking the shift function or else the shift linkage may be damaged.)
- ⑥ If the engine has been kept without running for a long time, the following operation is required before starting it.
 - Air purging for oil line—Refer to Item No. 5 Fuel and Engine Oil, Oil pump air vent.
 - Forced fuel feeding—Refer to Item No. 6 Running, 2 Starting.
 - Forced engine oil feeding—Refer to the same as above.

15. CHECKING AFTER STRIKING UNDERWATER OBJECT

Striking sea bottom or underwater object may severely damage the outboard. Immediately bring the outboard to your dealer and ask for the following checks.

(1) Looseness or damage of power unit installation bolts, gear case and extension case bolts, propeller shaft housing bolts, upper and lower mount rubber bolts and nuts, power trim and tilt bolts, and mount rubber cap bolts.

Ask to tighten loose bolts and nuts, and to replace damaged parts.

(2) Deformation and damage of mount rubber, tilt stopper, thrust rod, gears and clutch, and propeller.

Ask to replace damaged or deformed parts.

16. IF THE ENGINE BECOMES SUBMERGED IN WATER

After picking up, immediately bring the outboard to your dealer.

Following are the emergency measures to be taken on the submerged outboard.

- ① Take it out of water immediately and wash it with fresh water to remove all traces of salt and dirt.
- ② After picking up the engine, ask the dealer to perform the necessary actions to make sure the engine is brought back to a safe operating condition.

17. PRECAUTIONS IN COLD WEATHER

When mooring in cold weather at sub-zero temperatures the water in the cooling water pump may freeze and severely damage the pump, impeller, and associated parts. To avoid this, submerge the lower half of the engine into the water, or tilt the engine and operate the electric starter motor for 5 seconds with the stop switch lock plate taken away to allow the water to drain completely.

18. TROUBLESHOOTING

If you encounter a problem with the engine, check the list below and locate the problem you are experiencing. Then follow the suggested remedies.

Do not hesitate to contact your dealer, as professional advice and assistance is the best way to keep the engine in optimum condition.

Difficult to start engine	Engine runs erratically	Boat speed loss	Battery will not hold charge	Starter motor will not crank	Power Trim & Tilt inoperative	Possible Causes
●						Empty fuel tank
●	●					Incorrect connection of fuel system
●	●					Air enters fuel line
●	●					Deformed or damaged fuel pipe
●						Closed air vent on fuel tank cap
●	●					Fuel filter/fuel pump is clogged with dust.
●						Use of improper gasoline
●						Incomplete forced fuel feeding by primer bulb
●	●					Poor connection in compression system
●	●					Use of non-specified spark plugs
●	●					Dirt or carbon deposits on spark plugs
●	●					No sparking or poor sparking (Failure in component of ignition system)
	●					Insufficient cooling water flow

Difficult to start engine	Engine runs erratically	Boat speed loss	Battery will not hold charge	Starter motor will not crank	Power Trim & Tilt inoperative	Possible Causes
	●	●				Propeller cavitation
		●				Incorrect propeller selection
	●	●				Damaged or bent propeller
		●				Unbalanced loading. Overload
		●				Transom is too high/low.
		●				Bottom of the boat is stained or damaged.
●		●				Insufficient throttle aperture.
				●	●	Battery is charged insufficiently.
●			●	●	●	Battery is nearly dead, Poor connection of battery terminal, Low level of electrolyte
					●	Power trim & tilt switch is defective.
●				●		Wrong positioning of shift lever at N (neutral) position.
●			●	●	●	Main switch is defective.
●						Lock plate is not inserted or poorly inserted into stop switch.
●			●	●	●	Wrong wiring, disconnection, poor connection.
●				●		Faulty operation of starter motor/starter solenoid
					●	A great deal of air is contained inside pump.

19. TOOL KIT AND SPARE PARTS

Name			Remark
Servicing Tools	Tool Bag	1	Adapter-type
	Socket Wrench (16mm)	1	
	Socket Wrench (10 x 13)	1	
	Socket Wrench Handle	1	
	Pliers	1	
	Screwdriver (Phillips-type and flat head)	1	
Spare Parts	Rope (1,600mm)	1	NGK PZFR6H Diameter x length 3 x 25mm
	Spark Plug	3	
	Slit Pin	1	
Parts Packaged with Engine ※	Bracket Fixing Bolts	4	12 mm 12 mm A (large), B (small) } for EPTO
	Bracket Fixing Nuts	4	
	Washers A, B	4 each	
	Fuel Tank (with primer bulb)	1	
	Remote Control Box	1	
	Drag Link	1	
	Tachometer	1	
	Trim meter	1	
	Lead Wire for Meter	1	

※ Not included as standard accessories in some markets.

20. PROPELLER TABLE

To ensure optimum performance, the propeller should match the boat type and its load.

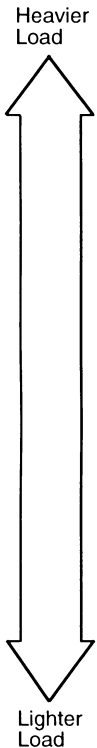

Mark	40	50	Mark	W50	Mark	70 · 90
※ 7			9		M-11	
CS9			10		M-13	
CS11			11		M-15	L · UL transom
CS12	S · L · UL transom		12	L · UL transom	M-16	
CS13		S · L · UL transom	13		M-17	
CS14			14		M-19	
CS15			15		M-21	
			16.5			
			17.5			

NOTE: “※” shows propeller with four blades.

PROPELLER

Use a genuine propeller.

A propeller must be selected so that the engine rpm measured at wide open throttle, while cruising, is within the recommended range.

5150 to 5850 rpm

21. OPTIONAL ACCESSORIES

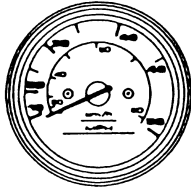

Speedometer
(50MPH)

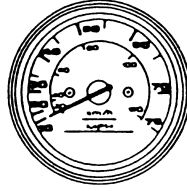

Speedometer
(75MPH)

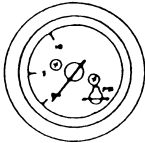

water Pressure
Meter

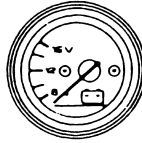

Voltmeter

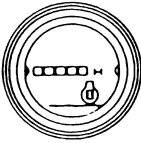

Hour Meter
(engine operation
hour counter)

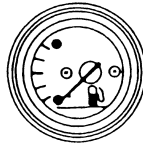

Fuel Meter

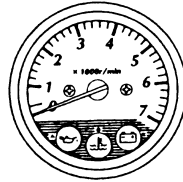

Tachometer



Flushing attachment

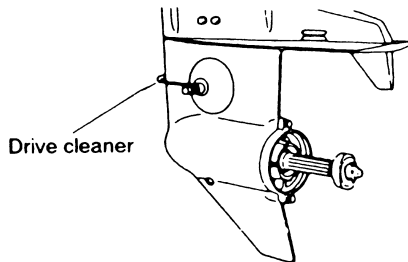

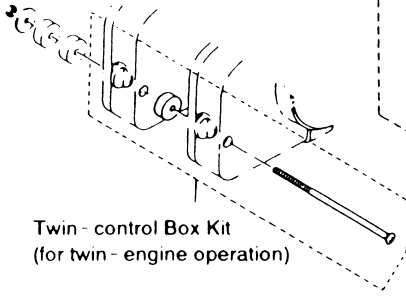

Twin-control Box Kit
(for twin-engine operation)

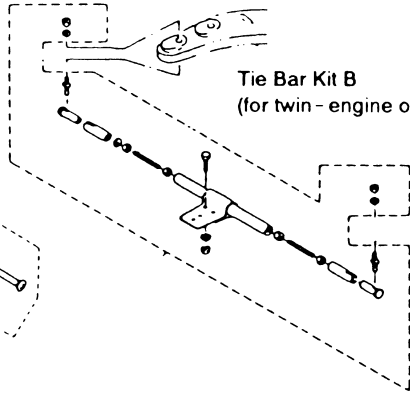

Tie Bar Kit B
(for twin-engine operation)



Propeller

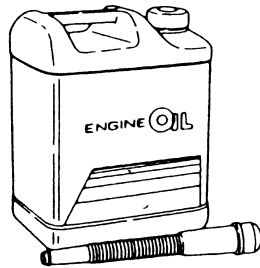

Engine Oil
(4L)



Grease
(250g)

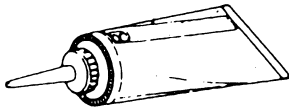

Grease Oil
(500mL)



Touch-up Spray Paint



Address: 5-4, 3-chome, Azusawa, Itabashi-ku, Tokyo 174-0051, Japan
Facsimile: (03) 3966-2951
Phone: (03) 3966-3117

No. 003-11075-6
03-01-MH500
Printed in Japan