

OWNER'S MANUAL

 **TOHATSU**

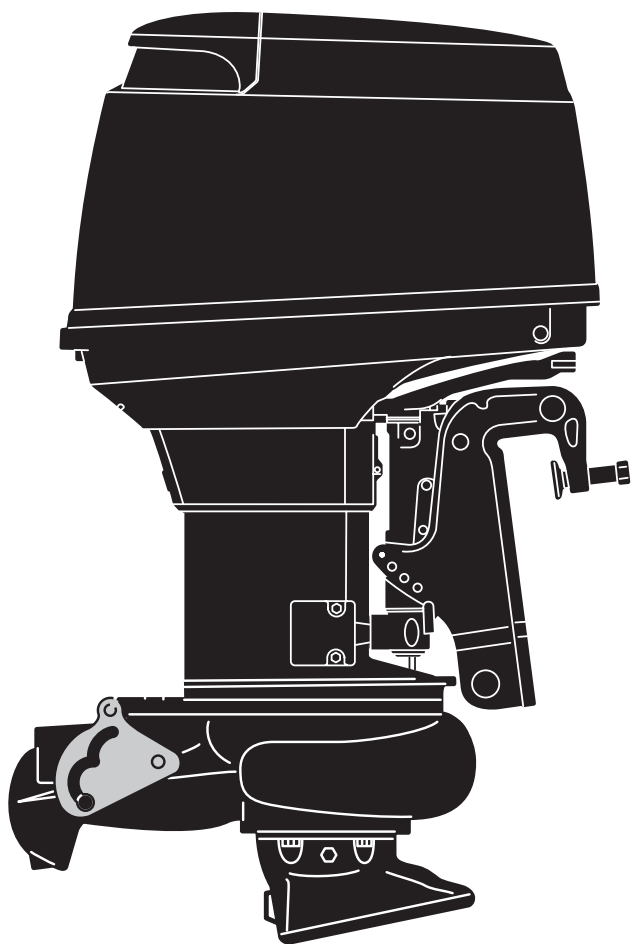

MD 35B₂

JET

Supplement

No.003-11095-0

Copyright © 2010 Tohatsu Corporation. All rights reserved. No part of this manual may be reproduced or transmitted in any form or by any means without the express written permission of Tohatsu Corporation.

Index

GENERAL INFORMATION	2
Before Operating Your Outboard	2
Specifications	3
Components	4
OPERATION	5
How the Jet Drive Operates	5
Stopping the Boat in an Emergency	6
Steering the Boat	6
Mooring The Boat	7
Water Intake Blockage	8
Clearing A Lodged Impeller	8
Lubricating the Driveshaft Bearing	9
Operating In Freezing Temperatures	9
Pre-Starting Check List	9
Operating In Salt Water Or Polluted Water	10
Operating In Shallow Water	10
MAINTENANCE.....	11
Impeller Removal and Installation	11
Worn/Dull Impeller	13
Steering Pull Adjustment	13
Impeller Clearance Adjustment	13
Replaceable Jet Drive Shear Key	14
Shift Cable Adjustment	15
Corrosion Control Anode	17
Lubricating the Driveshaft Bearing	17
TROUBLESHOOTING.....	19
Engine Over-Speed (Excessive RPM)	19
Performance Loss	19
ENGINE INSTALLATION	20
Transom height of the boat	20
Locate center line of the outboard	20
Determining the Mounting Height of the Outboard	21
Water Testing	22

GENERAL INFORMATION

Before Operating Your Outboard

Read this manual carefully. Learn the difference in handling characteristics between a jet drive boat and a propeller driven boat. If you have any questions, contact your dealer.

STEERING AT LOW SPEEDS

Unlike propeller driven boats, the jet drive boat tends to lose steering control as less water is drawn in and expelled. Increase speed slightly to regain steering.

MANEUVERABILITY

The jet drive is highly maneuverable at higher speeds, more so, than propeller driven boats. Use caution when turning to prevent spin - outs.

IN NEUTRAL

The impeller will continue to rotate while the engine is in neutral. Although the approximate balancing of forward and reverse thrust will minimize boat movement, the boat may tend to move slowly forward or backward. This is normal for a direct - drive jet driven boat. The operator should be aware of this and use caution whenever the engine is running.

Safety and operating information that is practiced, along with using good common sense, can help prevent personal injury and product damage.

This manual as well as safety labels posted on the outboard use the following safety alerts¹. to draw your attention to special safety instructions that should be followed.

DANGER

Indicates a hazardous situation which, if not avoided, will result in death or serious injury.

WARNING

Indicates a hazardous situation which, if not avoided, could result in death or serious injury.

Watch for boat movement in neutral. When the jet drive is in neutral, the drive impeller continues to rotate. Although the approximate balancing of forward and reverse thrust will minimize boat movement, the boat may tend to move slowly forward or backward. This is normal for a direct - drive jet driven boat. The operator should be aware of this and use caution whenever the engine is running.

Specifications

Owner's manual requires the correction. Please replace specification with below specification.

MODEL		MD 35B2 JET
Overall Length, in/mm		24.8/630
Overall Width, in/mm		13.6/345
Overall Height, in/mm		42.2/1,072
Recommended Transom Height, in/mm		20.5/521
Weight, lbs/kg		196.2/89
Output	Jet power, HP/kW	35/26.1
	Horsepower, HP/kW	50/36.8
Max, Operating Range		5,150 - 5,850
Number of Cylinders		3
Piston Displacement, Cu in/cc		42.5/697
Bore x Stroke, in/mm		2.68x2.52/68x64
Exhaust System		Jet Exhaust
Lubrication System		Oil injection
Cooling System		Water cooling
Starting System		Electric starter motor
Ignition		Inductive Ignition
Spark Plugs		NGK IZFR6Q
Alternator V · W		12V - 280W 23A
Trim Stages		4
Grease Driveshaft Bearing		3HT-65319-0
Gear Reduction Ratio		1 : 1

Components

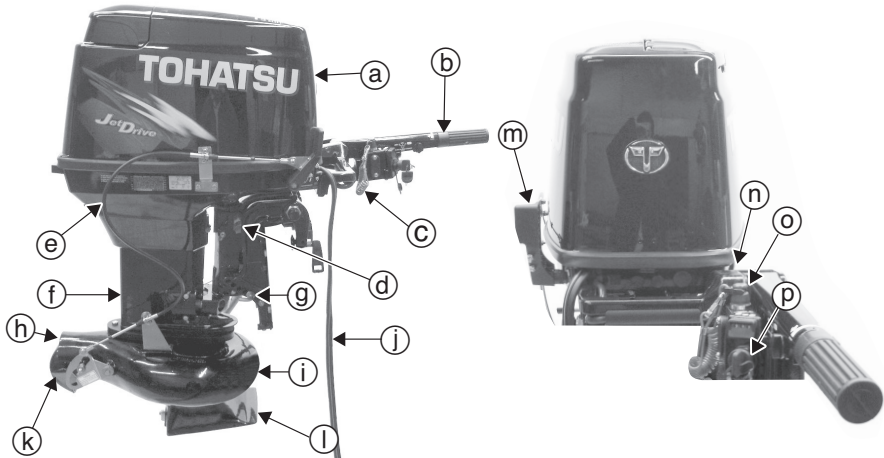

- Ⓐ Top Cowl
- Ⓑ Throttle Grip
- Ⓒ Stop Switch Lanyard
- Ⓓ Reverse Lock lever
- Ⓔ Shift Cable
- Ⓕ Drive Shaft Housing
- Ⓖ Thrust Rod
- Ⓗ Water Outlet
- Ⓙ Jet Drive Housing
- ⓫ Reverse Gate
- ⓬ Water Intake Housing
- Ⓜ Shift Lever
- Ⓝ Fuel Connector
- Ⓞ Stop Switch
- Ⓟ Main Switch

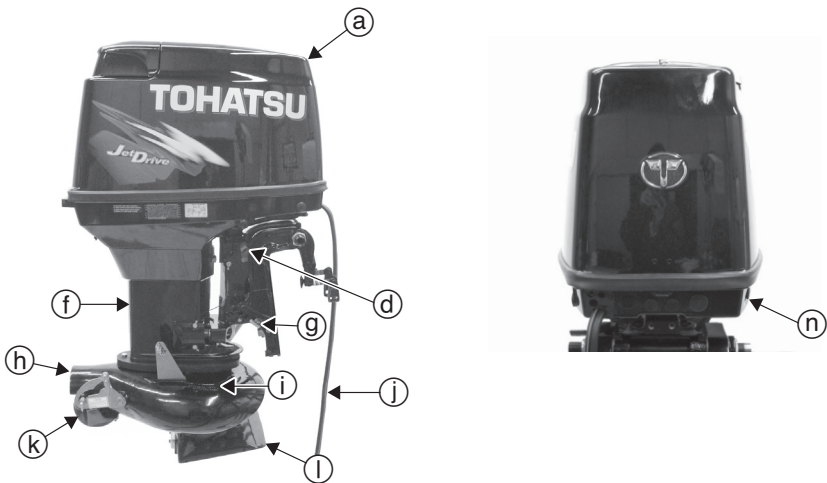

OPERATION

How the Jet Drive Operates

A jet driven boat has substantially different handling characteristics compared to a propeller driven boat. It is recommended that the operator adjusts to these characteristics by experimenting in open water at both high and low speeds. The driveshaft driven impeller draws water up through the water intake and then redirects it at a high pressure through the water outlet nozzle to create forward thrust. To obtain reverse, the reverse gate moves over the outlet nozzle to direct the water in the opposite direction.

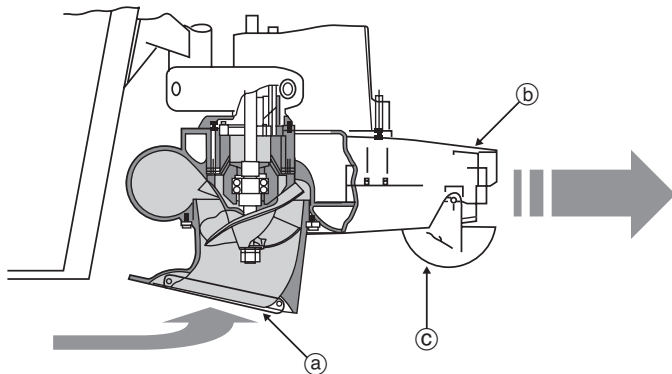

a - Water intake

b - Water outlet nozzle

c - Reverse gate

When the jet drive is in neutral, the impeller continues to rotate. However, the reverse gate is positioned so that some of the forward thrust is diverted to create reverse thrust. This approximate balancing of forward and reverse thrust will minimize any boat movement. Because the impeller is always rotating and creating thrust when the engine is running, the boat may tend to move slowly forward or backward. This is normal for a direct-drive jet driven boat. The operator should be aware of this and use caution whenever the engine is running.

⚠ WARNING

Avoid injury resulting from contacting the rotating impeller or having hair, clothing, or loose objects drawn into the water intake and wrapping around the impeller shaft. Stay away from the water intake and never insert an object into the water intake or water outlet nozzle when the engine is running.

The jet drive is always drawing water into the housing when the engine is running. Do not operate the jet drive with the grate removed from the water intake. Keep hands, feet, hair, loose clothing, life jackets, etc., away from the water intake. Never insert an object into the water intake or water outlet nozzle when the engine is running.

Stopping the Boat in an Emergency

A jet powered boat has emergency stopping capability unique to this form of propulsion.

⚠ WARNING

Using the emergency stopping capability of a jet drive unit will slow down the boat in an emergency. However, sudden stopping may cause the occupants of the boat to be thrown forward or out of the boat resulting in serious injury or death. Use caution when performing the emergency stopping procedure, and be sure to practice in a safe area.

In an emergency, putting the jet outboard into reverse and applying reverse throttle can rapidly slow down the boat and reduce stopping distance. However, such a maneuver may cause occupants in the boat to be thrown forward or possibly out of the boat.

Steering the Boat

The jet drive is dependent on water jet thrust for steering the boat. If the water jet thrust should ever stop (water blockage, engine stops, etc.), the boat will slow to a stop. However, while slowing there will be a reduced ability to steer the boat.

WARNING

Steering the vessel in a tight turn can result in loss of boat control. In some cases, the boat can spin out or roll over, causing serious injury or death. Avoid steering beyond the capabilities of the vessel, especially at high speeds.

WARNING

A loss or reduction in water jet thrust will directly affect boat directional control, and may result in property damage, personal injury, or death. Boat directional control can also be substantially reduced or lost altogether by a sudden loss of power such as running out of gas, quickly backing off the throttle, turning off the ignition switch, activating the lanyard stop switch, or plugging the water intake to the jet pump. Use caution when maneuvering at high speeds in areas where debris (weeds, logs, gravel, etc.) could be picked up into the jet drive. The ability to take evasive action is dependent on sufficient water jet thrust to control the boat.

While steering the boat at engine speeds above idle, the boat will respond quickly; but, due to the relatively flat-bottom hulls and lack of a gearcase in the water, the boat will tend to skid on turns. Turns must be started early and use sufficient power to maintain steering control.

Mooring The Boat

Be sure to tilt the jet drive out of the water when the boat is pulled onto a beach or tied to a dock in shallow water. Failure to do this may cause the water intake housing to fill with sand or debris and could prevent the outboard from cranking over for starting.

Water Intake Blockage

WARNING

A rotating impeller could cause injury if contact is made with hands, clothing, or tools. To avoid injury, keep hands and clothing away from the inlet or outlet of the jetdrive, regardless of whether the boat is in the water. Secure tools and loose items to avoid being struck by projectiles as a result of contact with the rotating impeller, and to prevent damage to the impeller.

A large amount of debris being drawn into the water intake may result in a loss of power. Intake suction holding debris against the grate will result in restricted water flow. Shutting the engine off may allow the debris to fall off the intake grate allowing full power to be restored. If debris does not fall off the intake grate, the engine must be shut off and debris physically removed from the grate.

Clearing A Lodged Impeller

WARNING

Rotating the flywheel to free a lodged impeller can accidentally start the engine, resulting in serious injury or death. Always turn the ignition key or lanyard stop switch to the “OFF” position and remove all spark plug leads from the spark plugs.

It is possible for debris to lodge between the impeller and jet housing wall, especially after the engine has been stopped. This will lock the driveshaft and will prevent the engine from being able to crank over for starting. Following are steps for dislodging the impeller.

- 1. Position lanyard stop switch to the “OFF” position.**
- 2. Remove spark plug leads to prevent the engine from accidentally starting.**
- 3. Remove flywheel or rewind cover and rotate the engine flywheel counterclockwise.**

If this does not dislodge the impeller, it will be necessary to remove the six screws and water intake housing.

Lubricating the Driveshaft Bearing

Before each use, lubricate the driveshaft bearing. Refer to **Maintenance - Lubricating the Driveshaft Bearing**.



Operating In Freezing Temperatures

If there is a chance of ice forming on the water, the jet drive should be raised out of the water and drained completely of water. If ice should form at the water level inside the outboard driveshaft housing, it will block water flow to the engine causing possible damage. Do not start the engine until the ice is clear.

Pre-Starting Check List

- Operator knows safe navigation, boating, and operating procedures.
- An approved personal flotation device of suitable size for each person aboard and readily accessible (it is the law).
- A ring type life buoy or buoyant cushion designed to be thrown to a person in the water.
- Know your boats maximum load capacity. Look at the boat capacity plate.
- Fuel supply OK.
- Ensure the boat drain plug is installed.
- Arrange passengers and load in the boat so the weight is distributed evenly and everyone is seated in a proper seat.
- Tell someone where you are going and when you expect to return.

-
- Know the waters and area you will be boating; tides, currents, sand bars, rocks, and other hazards.
 - Check steering for free operation.
 - Check for debris around the rudder and reverse gate which may jam or hinder operation.
 - Before launching, examine the jet drive water intake for obstructions which may prevent pumping of water.
 - Ensure the driveshaft bearing on the jet drive is lubricated.

Operating In Salt Water Or Polluted Water

If the boat is kept moored in the water, always tilt the outboard so the water intake is completely out of water when not in use.

Wash down the outboard exterior and flush out the exhaust outlet of the jet drive with fresh water after each use.

When used in salt water more than in fresh water, remove mounting hardware, grease, and reassemble once a year. Failure to do this may result in hardware that is difficult if not impossible to remove at a later date.

Operating In Shallow Water

The life of the impeller and water intake can be greatly increased by avoiding the intake of sand and gravel. The intake suction will act like a dredge when the water intake comes close to the bottom. It is better to stop the engine and drift up to shore when landing, and to shove off with an oar when leaving. The engine can idle through areas of water less than 61 cm (2 ft.) deep, but there should be more than 61 cm (2 ft.) of water under the boat when increasing speed to reach full plane.

Once the boat is on plane, the boat speed will prevent the ingestion of gravel and other debris from the bottom. The suction is still present, but the water intake passes too quickly over the bottom to allow debris to be drawn into the water intake.

When boating through shallow water areas, choose a course of travel that avoids sharp rocks and other underwater obstacles that could damage the boat. Running the boat through these areas on full plane may be helpful as the boat will be riding higher in the water. If the boat gets stuck on the bottom, immediately stop the engine and move the boat to deeper water.

MAINTENANCE

Impeller Removal and Installation

⚠ WARNING

Rotating the driveshaft may cause the engine to crank over and start. To prevent this type of accidental engine starting and possible serious injury caused from being struck by a rotating impeller, always turn the ignition key or lanyard stop switch to the “OFF” position and remove the spark plug leads from the spark plugs while servicing the impeller.

- 1.** Position the key switch or lanyard stop switch to the “OFF” position.
- 2.** Remove the spark plug leads to prevent the engine from starting.

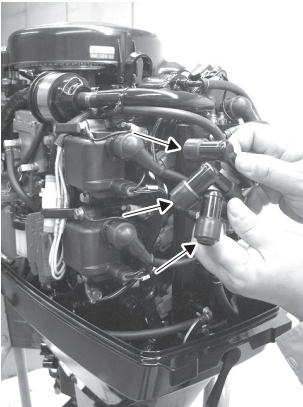

- 3.** Remove the six screws securing the water intake housing, and remove the water intake housing.

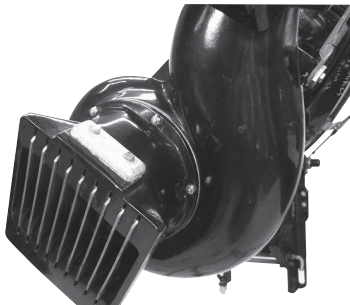

-
- 4.** Straighten the bent tabs on the impeller nut retainer and remove the impeller nut.

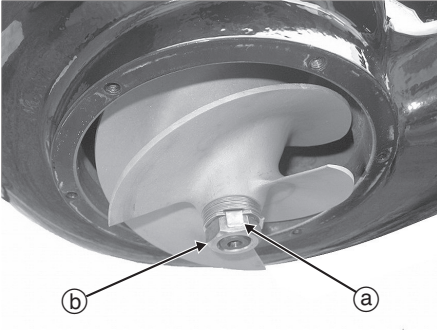

a - Tabs

b - Impeller nut

- 5 .** Pull the impeller straight off the shaft.

If the impeller is tight, use a hammer and a block of wood to rotate the impeller clockwise on the shaft until the keyway is directly above the flat on the shaft. This will free the jammed key and allow removal.

Worn/Dull Impeller

The intake of gravel through the pump can round off and wear the leading edges of the impeller. Some conditions that could be experienced from a worn/dull impeller are as follows:

- Noticeable performance loss, especially on acceleration
- Difficulty getting the boat on plane
- An increase in engine RPM at wide open throttle

IMPORTANT : Do not sharpen or alter the top side lifting angle. Check the impeller blades occasionally for damage. Use a flat file to resharpen the leading edges. Sharpen to a 0.8 mm (1/32 in.) radius by removing material from bottom side only.

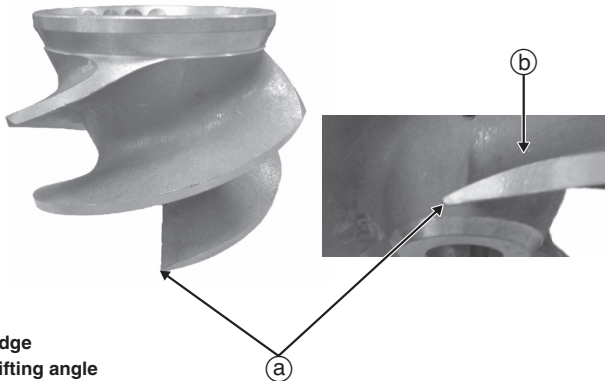

- a - Leading edge
- b - Top side lifting angle

Steering Pull Adjustment

The steering on some boats will have the tendency to pull towards starboard. This pulling condition can be corrected by using a pliers and bending the ends of the exhaust fins 1/16 in. (1.5mm) toward the starboard side of the outboard.

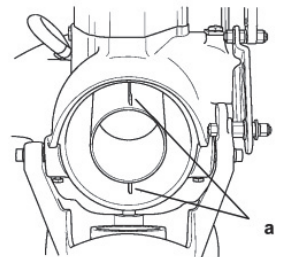

- a - Exhaust fin

Impeller Clearance Adjustment

The impeller should be adjusted so there is approximately 0.8 mm (0.031 in.) clearance between the impeller edge and liner. Operating the jet drive in waters that contain sand and gravel can cause wear to the impeller blades, and the clearance will start to exceed 0.8 mm (0.031 in.).

As the blades wear, shims located in the stack outside of the impeller can be transferred behind the impeller. This will move the impeller further down into the tapered liner to reduce the clearance.

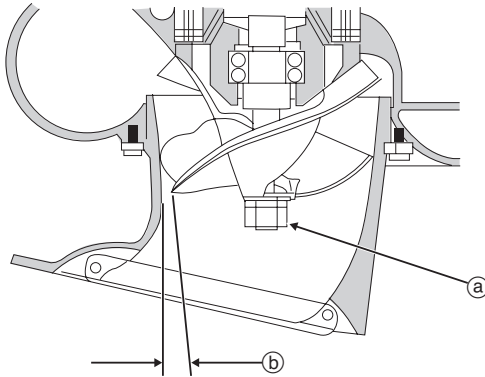

a - Shims

b - Clearance between impeller edge and liner

Check the impeller clearance by sliding a feeler gauge through the intake grate and measure the clearance between the impeller edge and liner. If adjustment is required, refer to **Impeller Removal and Installation**.

Replaceable Jet Drive Shear Key

The jet drive is equipped with a shear key to protect it in the event of a lodged impeller. The shear key can be reached by removing the water intake housing and impeller. Grease the drive shaft, shear key, and impeller bore when replace these parts. **Refer to Maintenance-Impeller Removal and Installation**.

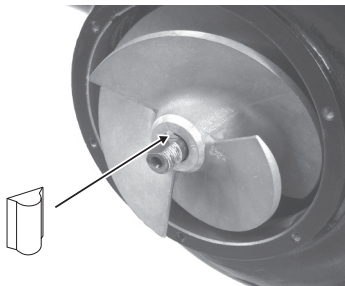

Shift Cable Adjustment

⚠ WARNING

Pressurized water hitting the reverse gate may cause it to engage, causing sudden and unexpected slowing of the boat. This can cause serious injury or death from occupants being thrown within or out of the boat. Adjust the shift link rod to lock the reverse gate, preventing it from interfering with water flow.

CHECKING SHIFT LINK ROD ADJUSTMENT

Check the shift link rod adjustment in forward shift position. The correct adjustment will position the shift cam far enough on the roller in order to lock the reverse gate into forward position. The reverse gate should not be able to be forced up towards neutral. Pull on the reverse gate by hand to verify.

F type

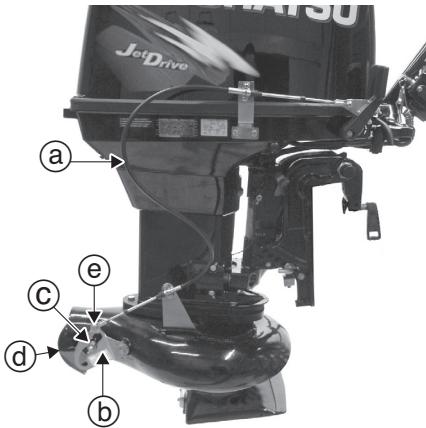

P type

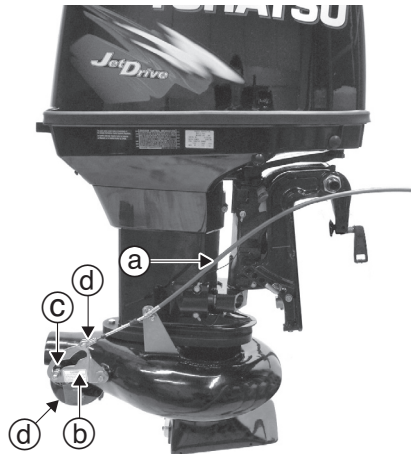

a - Shift cable
b - Shift cam

c - Roller
d - Reverse gate
e - Ball end

- 1.** Place roller at bottom of shift cam groove as shown.

Correct

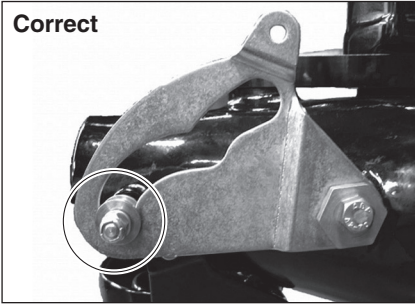

Incorrect

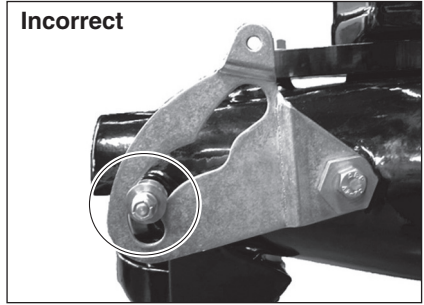

- 2.** Place the shift lever and shift cam into full forward position.

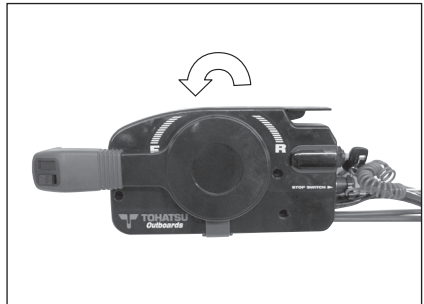
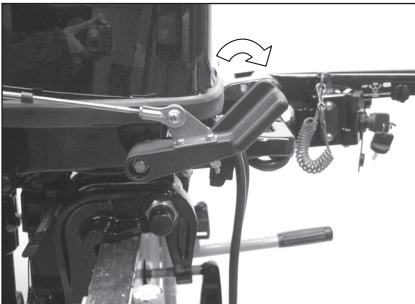

- 3.** Bring groove A to position B and secure the part.

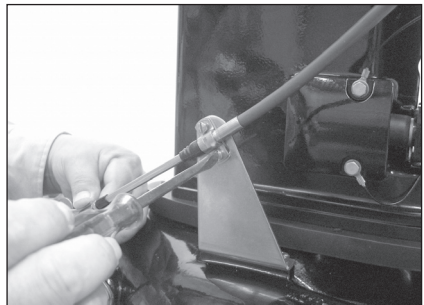
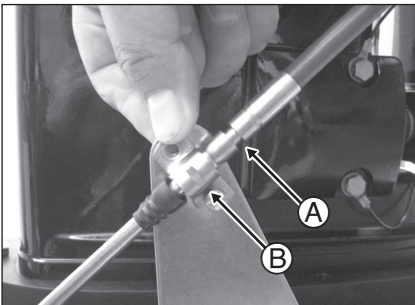

-
- 4.** Attach ball end to shift cable, align the hole as shown, and secure the part.

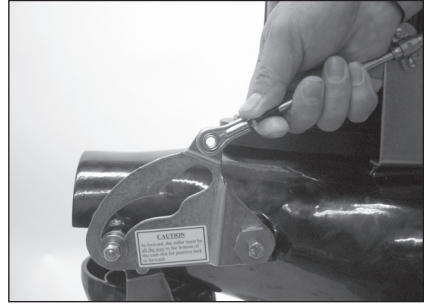
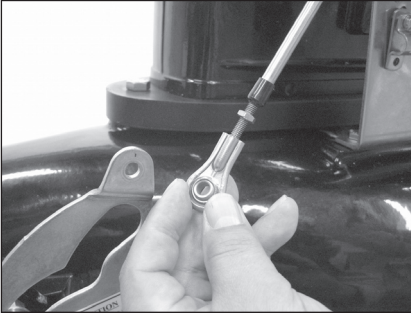

- 5.** The reverse gate should not be able to be forced up towards neutral.
Pull on the reverse gate by hand to verify.

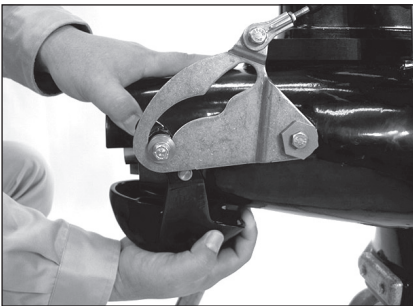

Corrosion Control Anode

An anode helps protect the outboard against galvanic corrosion by sacrificing its metal to be slowly corroded instead of the outboard metals.

An anode is located on the water intake housing. An anode requires periodic inspection, especially in salt water which will accelerate the erosion. To maintain this corrosion protection, always replace the anode before it is completely eroded. Never paint or apply a protective coating on the anode as this will reduce effectiveness of the anode.

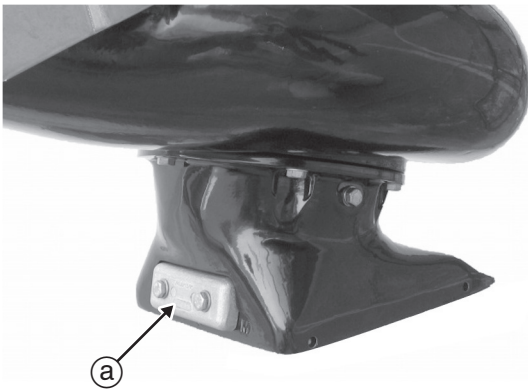

a - Water intake housing anode

Lubricating the Driveshaft Bearing

Lubricate the driveshaft bearing before each use.

Description	Where to used	Part No.
Grease	Drive shaft bearing	3HT-72309-0
Grease Gun	Drive shaft bearing	3HT-65324-0

IMPORTANT : It is important not to use a general all purpose grease for this bearing. The lubricant recommended is a water resistant grease of the proper consistency for this application. If a substitute is used, be sure that it is water resistant and of the same consistency.

- 1.** Pull the vent hose off of the grease fitting.
- 2.** Pump in grease through the grease fitting, using the grease gun provided, until excess grease starts to exit the vent hose.
- 3.** Reconnect the vent hose onto the grease fitting after greasing.



a - Grease fitting

b - Vent hose

NOTE : After 30 hours of operation, pump in extra grease to purge out any moisture.

Visually inspecting the purged grease at this time will give an indication of conditions inside the bearing housing. A gradual increase in moisture content indicates seal wear. If the grease begins to turn dark or dirty gray, the driveshaft bearing and seals should be inspected and replaced if necessary. Some discoloration of the grease is normal during the break-in period on a new set of seals.

TROUBLESHOOTING

Engine Over-Speed (Excessive RPM)

POSSIBLE CAUSES

- Outboard mounted too high on the transom.
- Worn jet pump impeller or liner.
- Incorrect jet pump impeller clearance adjustment.
- Tilting the outboard out beyond a vertical position.
- Cavitation of the impeller due to rough water or obstruction in the boat hull.
- Blockage of the water intake.

Performance Loss

POSSIBLE CAUSES

- Throttle not fully open.
- Damaged impeller.
- Incorrect engine timing, adjustments, or setup.
- Boat overloaded or load improperly distributed.
- Excessive water in bilge.
- Boat bottom is dirty or damaged.

ENGINE INSTALLATION

Transom height of the boat

Outboards with jet drives will be mounted approximately 7 inches higher on the transom than propeller driven outboards. This requires outboards that have a 15 in. shaft length to be installed on boats having a 22 in. transom height.

If the boat transom is of insufficient height, and the outboard cannot be installed to the recommended height, contact the boat manufacturer for recommended procedure to build up the boat transom.

Locate center line of the outboard

Locate (and mark with pencil) the vertical centerline (a) of boat transom.

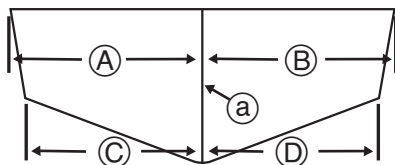

a - Centerline of transom

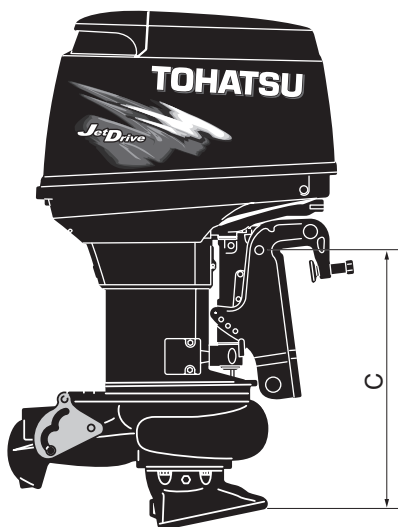

C = 521 mm / 20.5 in

Determining the Mounting Height of the Outboard

The following outboard mounting height settings will work good for most applications, however, because of different boat/hull designs, the setting should be rechecked by test running the boat. Refer to **Water Testing**.

- Installing the outboard too high on the transom will allow the water intake to suck in air and cause cavitation. Cavitation causes the engine to overspeed in spurts and reduce thrust. This condition should be avoided by proper height setting.
- Installing the outboard too low on the transom will allow excessive drag.

BOATS WITH A “V” BOTTOM HULL

1. Measure the width of the leading edge on the water intake housing.

Make a horizontal line on the transom up from the “V” bottom the same length as the width of the water intake housing.

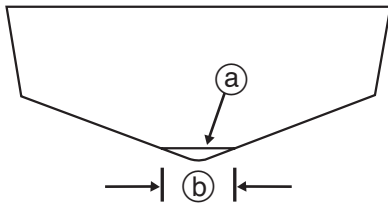

a - Horizontal line

b - Width of the leading edge on the water intake housing

2. Place (center) the outboard on the boat transom.

Set the height of the outboard on the boat transom so that the front edge of the water intake housing is in line with the horizontal line made in step 1. Fasten the outboard to the transom at this height.

BOATS WITH A FLAT BOTTOM HULL

1. Place (center) the outboard on the boat transom.

Set the height of the outboard on the boat transom so that the front edge of the water intake housing is in line with the bottom of the boat as shown. Fasten outboard to the transom at this height.

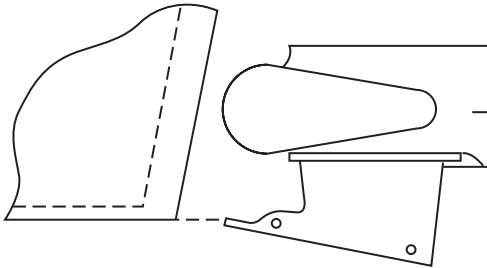

Water Testing

CHECKING FOR CAVITATION

The initial outboard height setting should be close to the optimum setting for the outboard. However, because of the hull design of some boats, obstructions, or imperfections in the hull ahead of the water intake, adjustments may be required to prevent cavitation at running speeds. When operating the boat, the outboard driveshaft housing should be vertical, or tilted toward the boat, when planing to provide a scooping angle on the water intake. Tilting the outboard out beyond a vertical position reduces the scoop angle and can cause impeller slippage and cavitation.

IMPORTANT : If the angle of the boat transom does not allow the driveshaft housing to be positioned vertical, a wedge kit should be installed behind the transom brackets to increase the tilt-in angle.

NOTE : Slight cavitation in sharp turns and rough water is acceptable, but excessive cavitation is harmful to the outboard and should be avoided. Test run the boat. If cavitation occurs (air enters the pump), the first thing to try is lowering the outboard mounting height.

If cavitation still exists after lowering the outboard, it may be helpful to seek advice from the boat manufacturer.

Another option to further reduce cavitation is a rough water plate. A rough water plate may be helpful in reducing cavitation when running in windy, rough water conditions where air is sucked into the water intake when jumping waves. Install a 0.8 mm (1/32 in.) metal plate that extends from the hull bottom to the top of the water intake housing. This plate tends to reduce air intake as well as reduce spray.

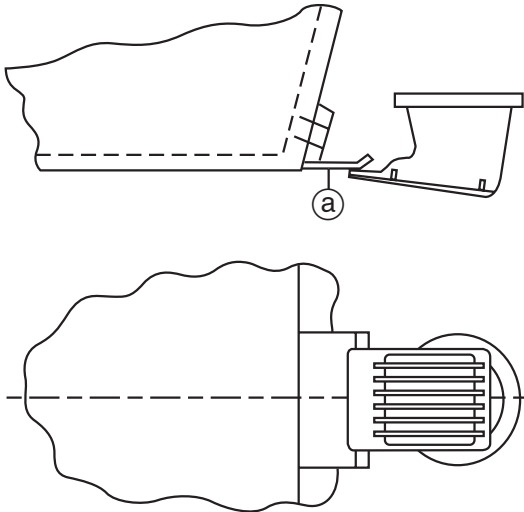

a - Rough water plate

TOHATSU CORPORATION

**Address : 5-4, 3-chome, Azusawa, Itabashi-ku,
TOKYO, 174-0051 JAPAN**

Phone : TOKYO (03)3966-3117

FAX : TOKYO (03)3966-2951

URL : www.tohatsu.co.jp

OWNER'S MANUAL

MD 35B₂

JET

Supplement