

V20E
 V20ES
 V20ES-R ポンプ性能曲線

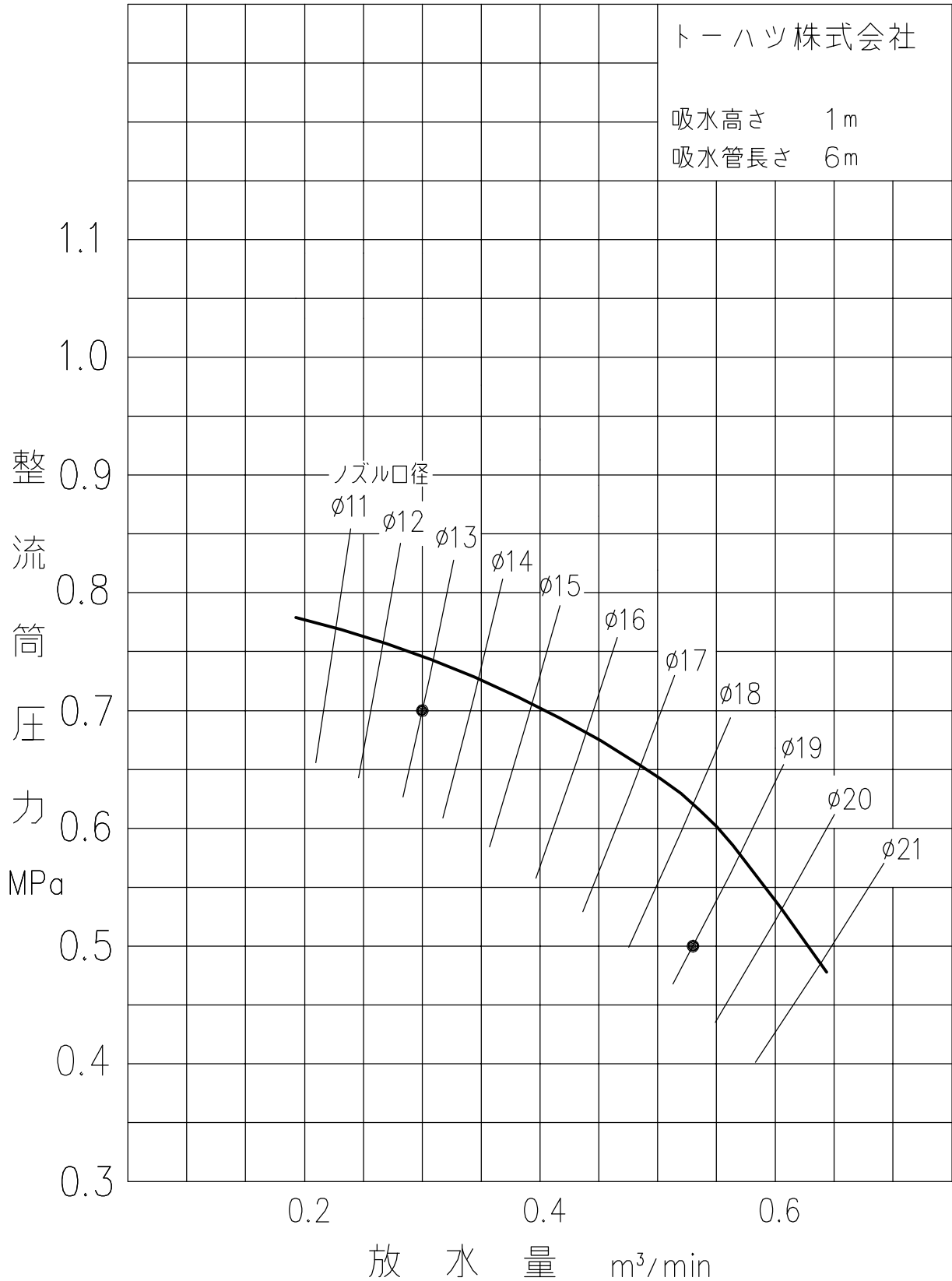

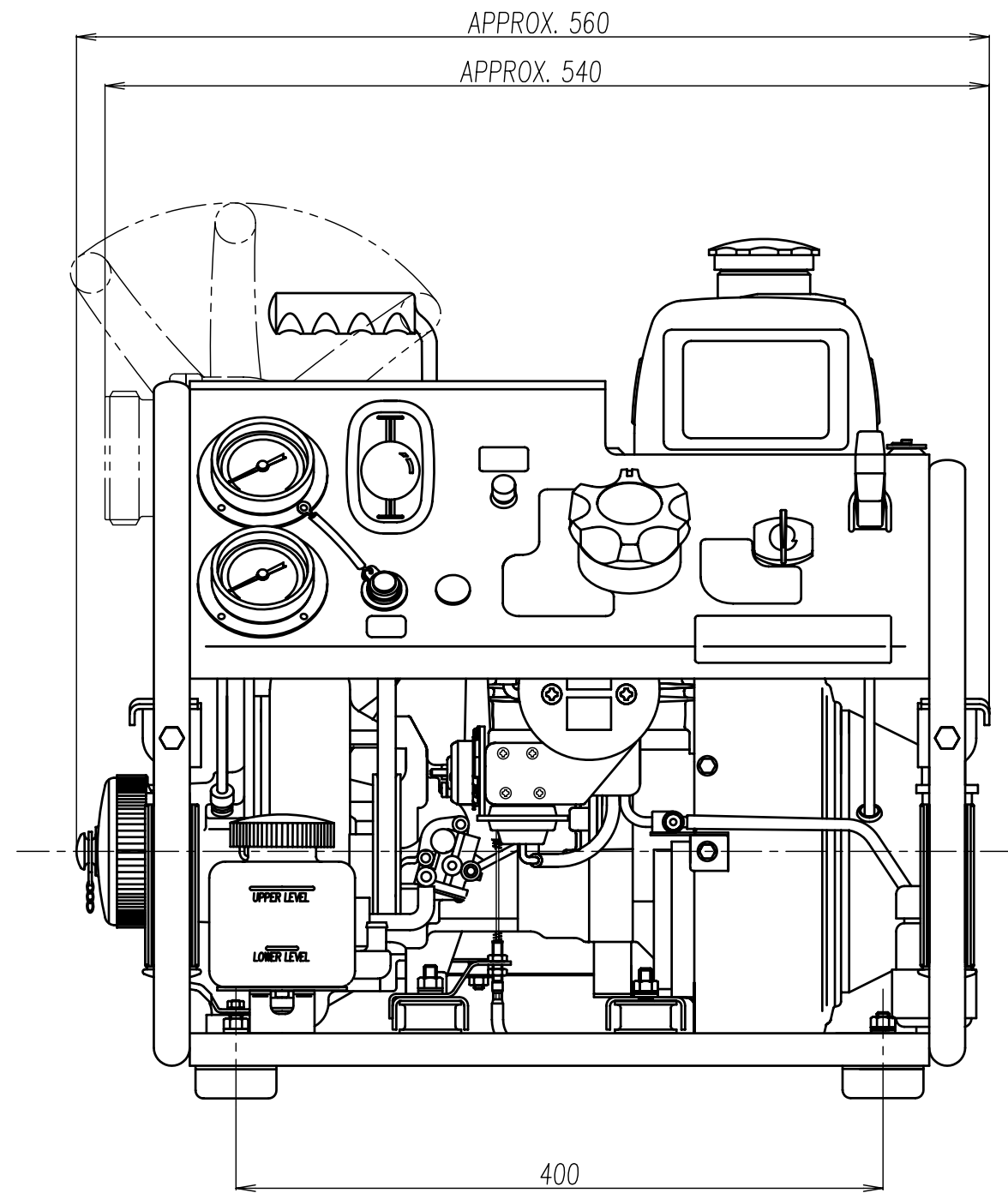
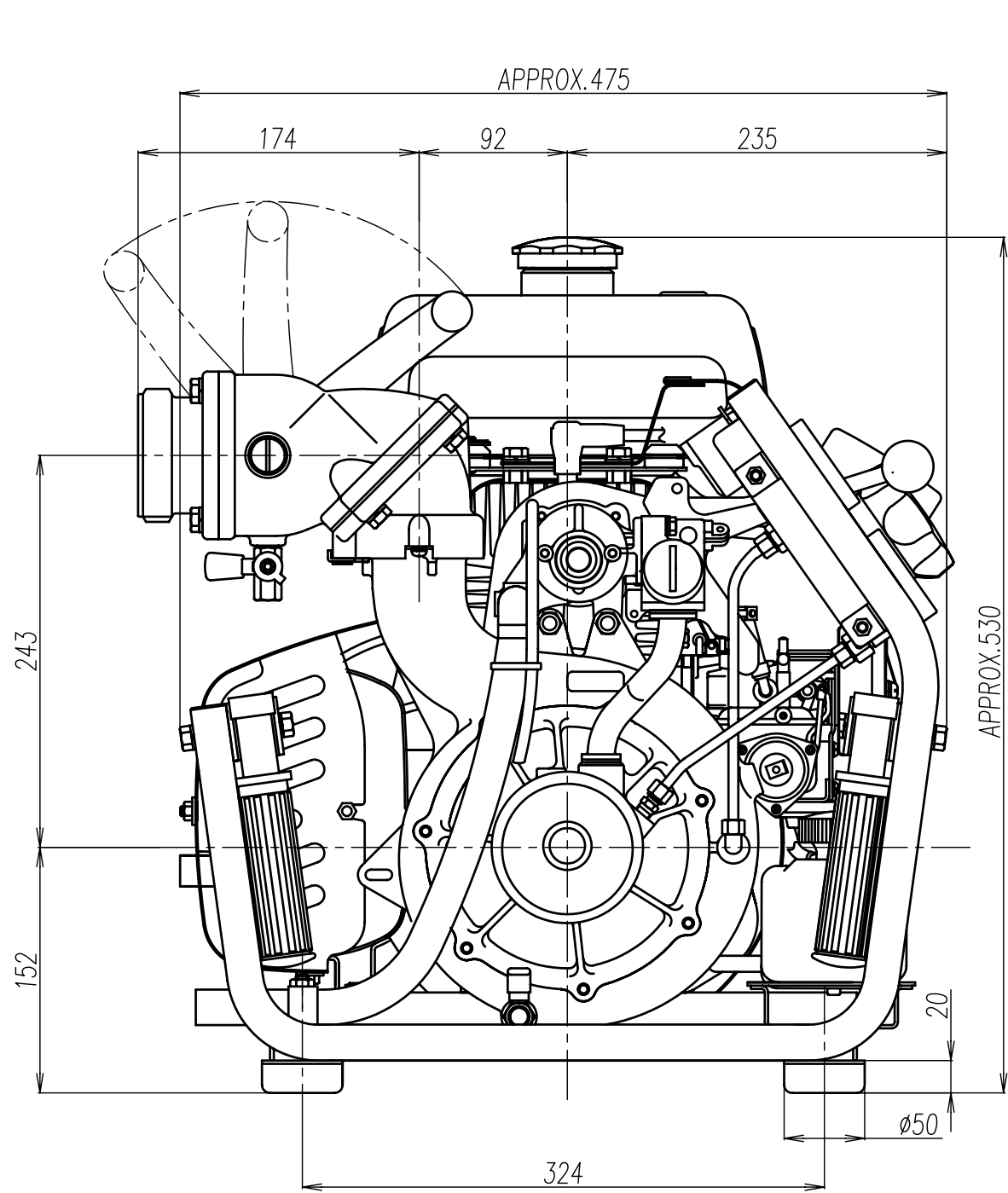

A	Thread of Discharge Port	JIS B-9912 Dimension of Screwed Type Coupling for Fire Hose 2-1/2" (ø82.5 5 Threads Per inch Angle of Threads 55°)	060301	MODEL	V20E
	吐出側ネジ	W ø82.5 ^{-0.46} / _{-0.73} JIS B-9912 消防ネジ結合金具 呼び 65 山 5/吋ネジ 山角度 55°			
B	Thread of Suction Port	JIS B-9912 Dimension of Screwed Type Coupling for Fire Hose 2-1/2" (ø82.5 5 Threads Per inch Angle of Threads 55°)	PART NO.	OUTLINE DRAWING	
	吸水側ネジ	W ø82.5 ^{-0.46} / _{-0.73} JIS B-9912 消防ネジ結合金具 呼び 65 山 5/吋ネジ 山角度 55°			
			TOHATSU		