

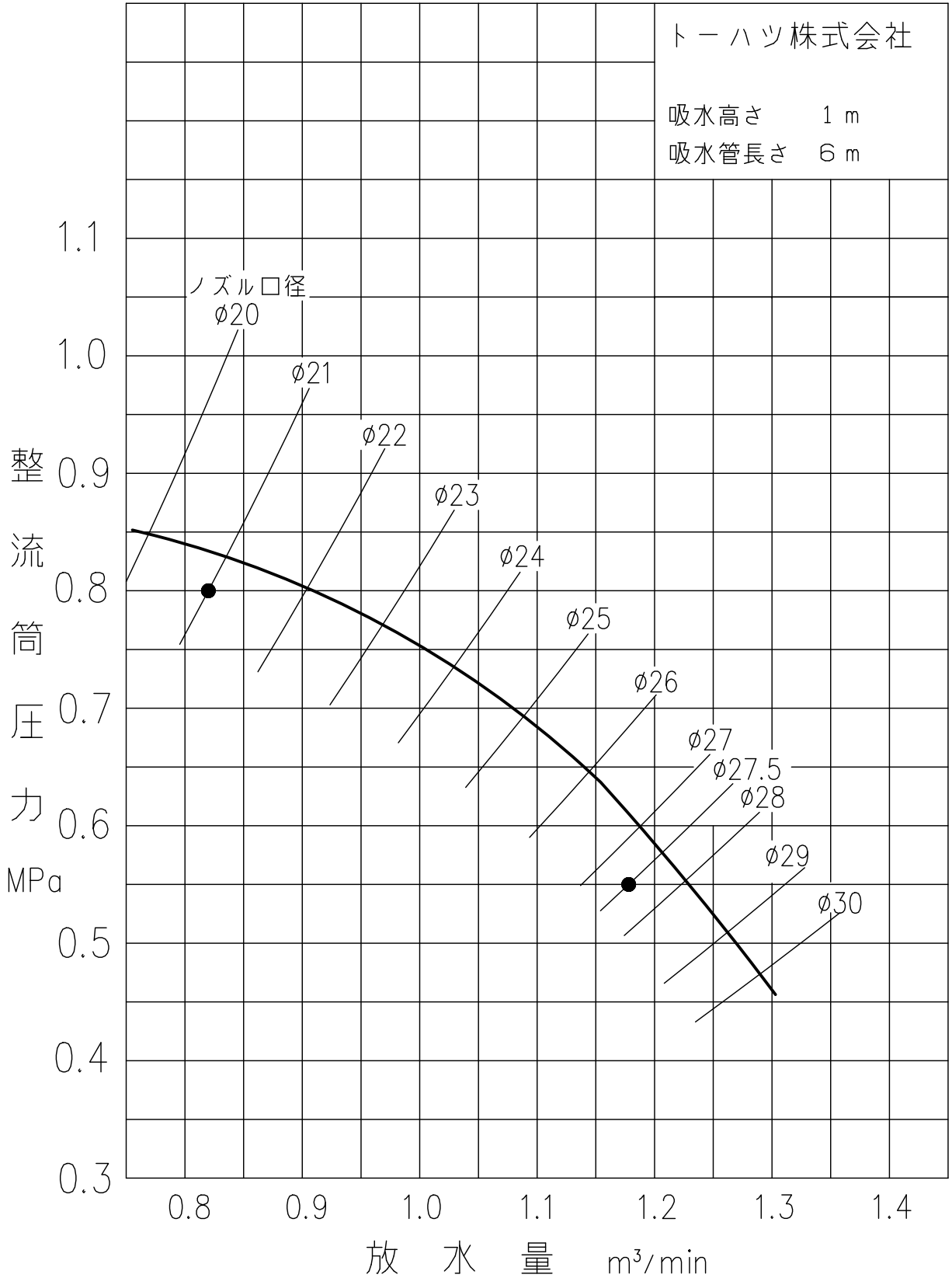

# V40BS ポンプ性能曲線

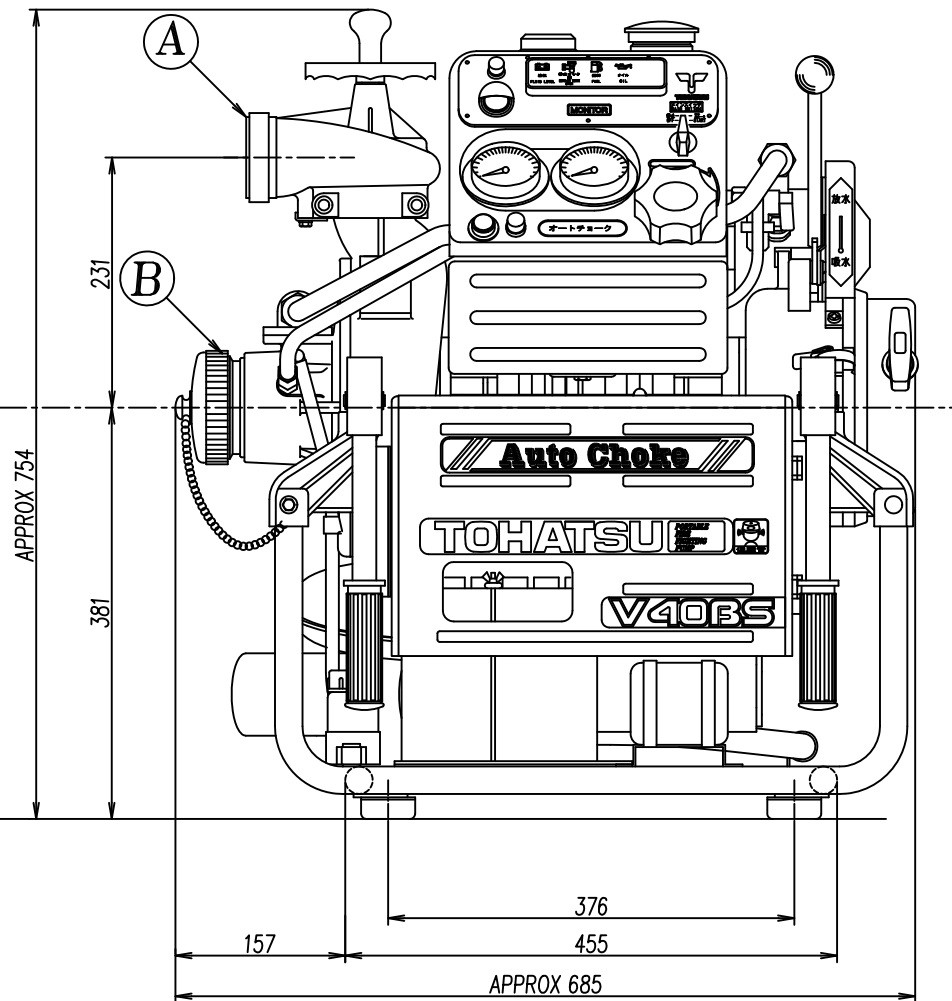

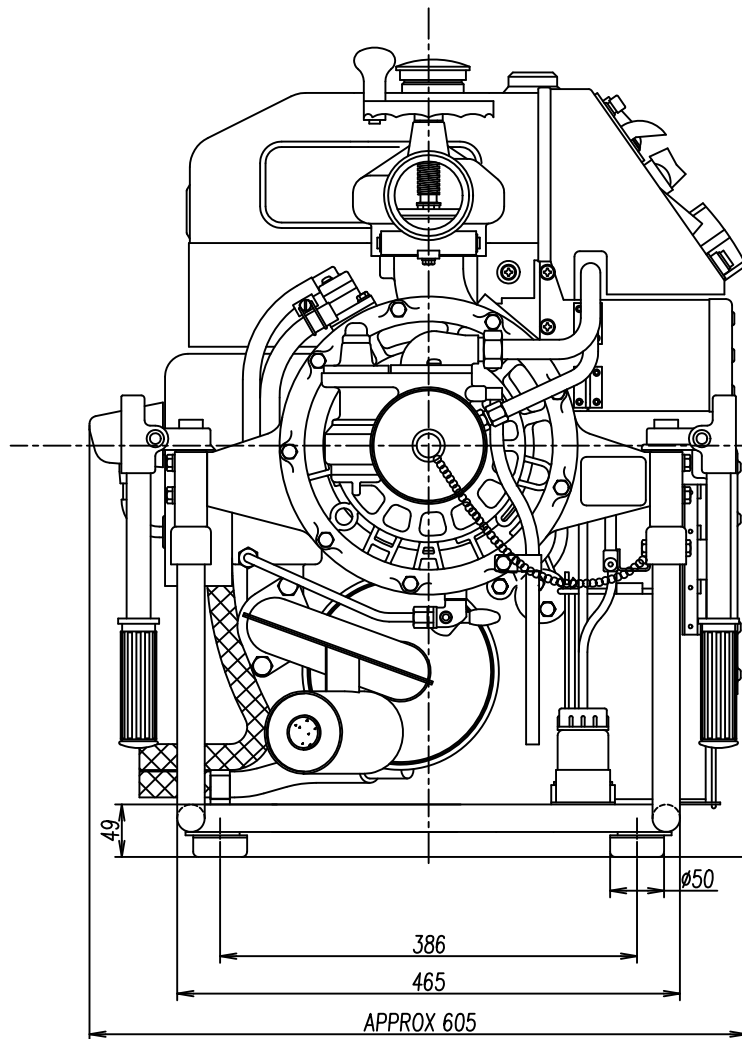

A	Thread of Discharge Port	JIS B-9912 Dimension of Screwed Type Coupling for Fire Hose 2-1/2" ( $\phi 82.5$ 5 Threads Per inch Angle of Threads 55°)	050630	MODEL	V40BS
	吐出側ネジ	W $\phi 82.5$ $-0.46$ 呼び 65 山 5/吋ネジ 山角度 55°	JIS B-9912 消防ネジ結合金具	PART NAME	OUTLINE DRAWING アウトライン ドローイング
B	Thread of Suction Port	JIS B-9912 Dimension of Screwed Type Coupling for Fire Hose 3" ( $\phi 95$ 4 Threads Per inch Angle of Threads 55°)	PART NO.	1A6-80023-000	
	吸水側ネジ	W $\phi 95$ $-0.55$ 呼び 75 山 4/吋ネジ 山角度 55°	TOHATSU		