

VF21A(S) 性能曲線

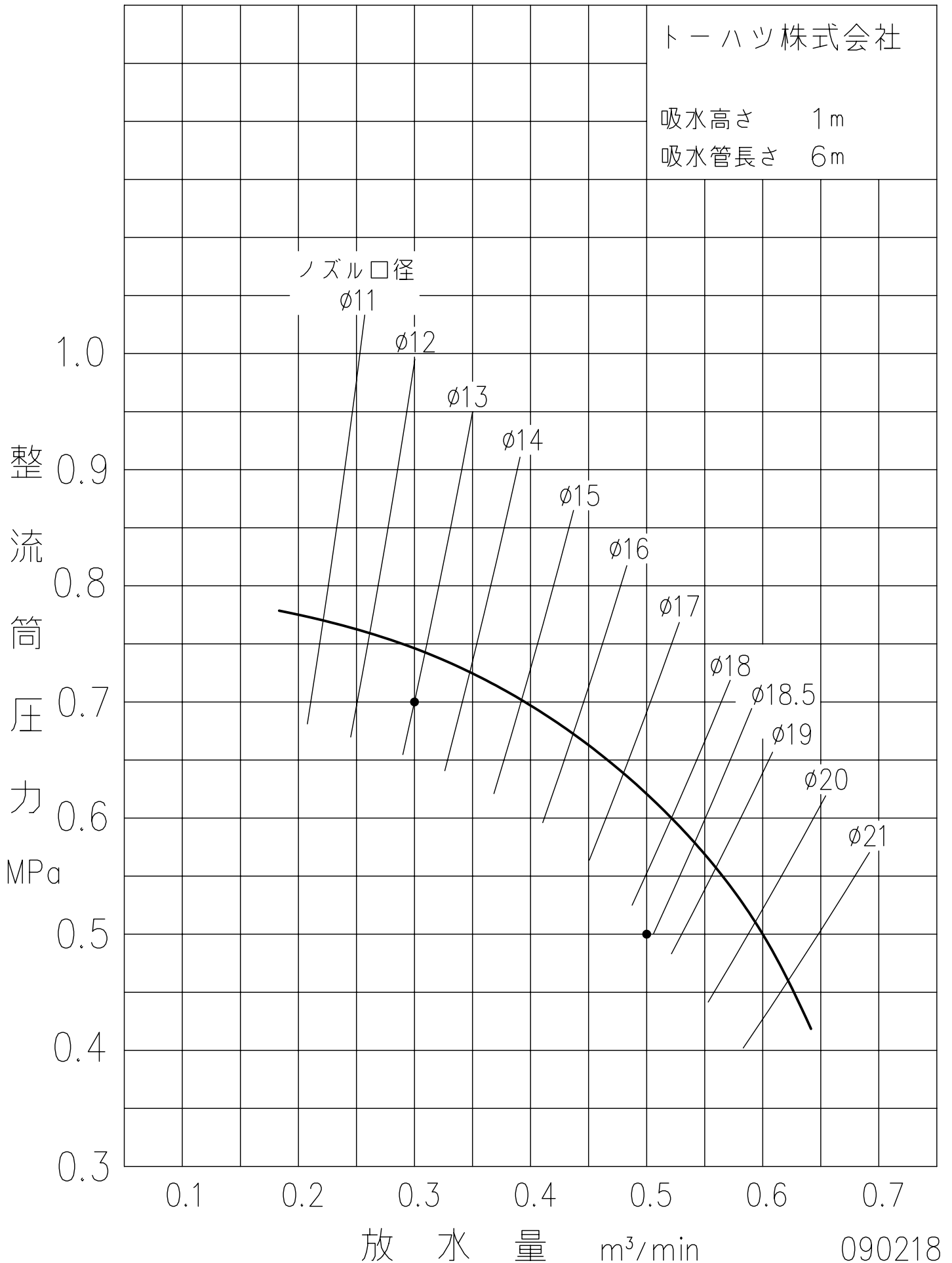

VF21A(S) 各部名称

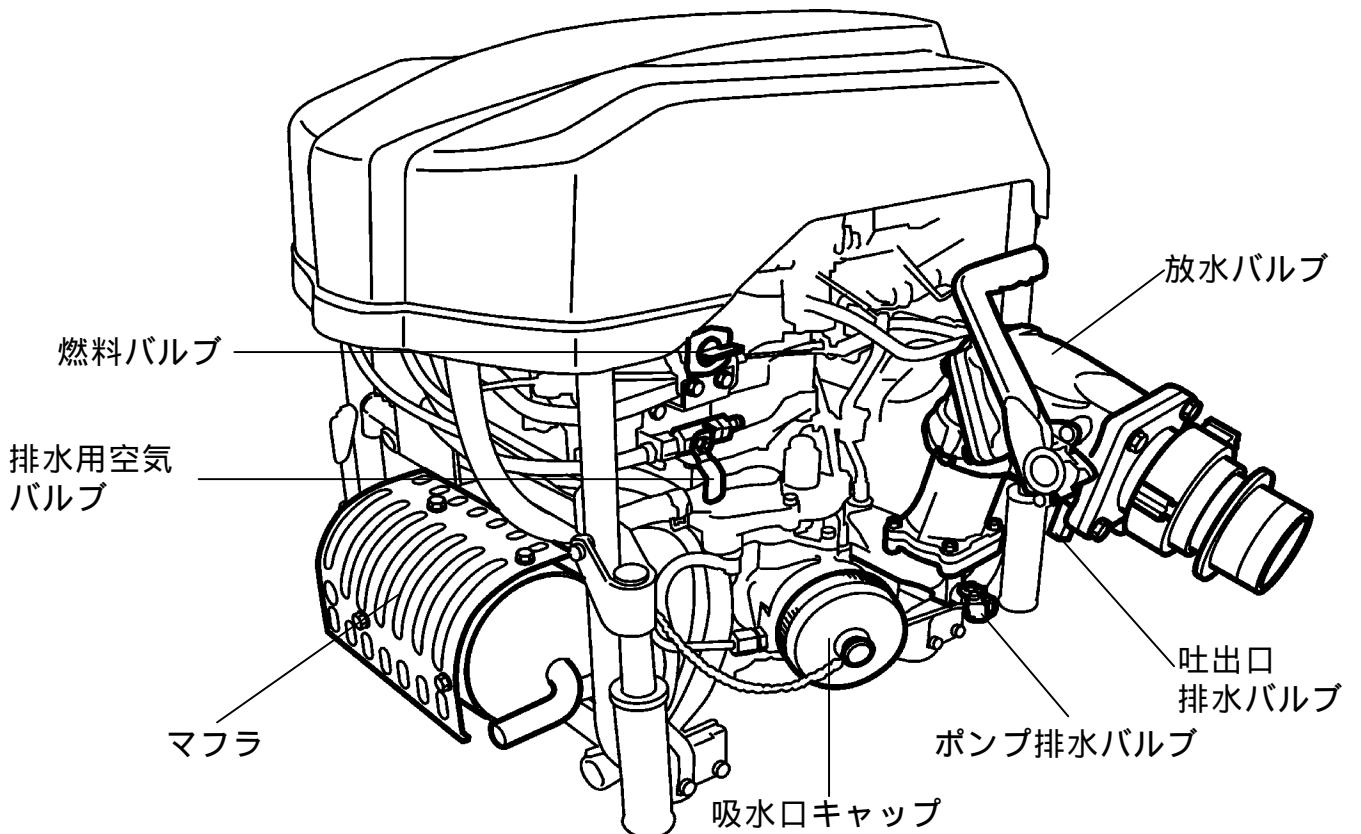

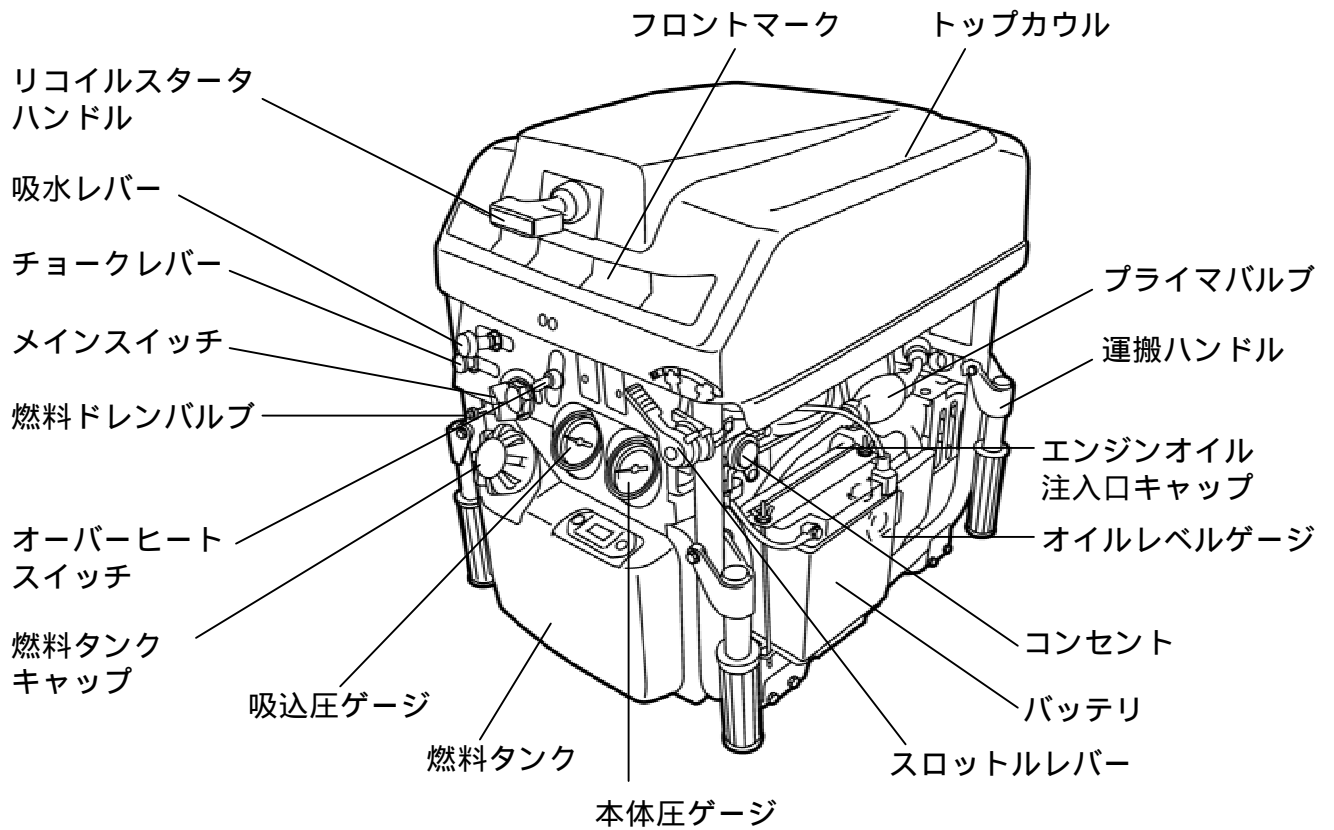
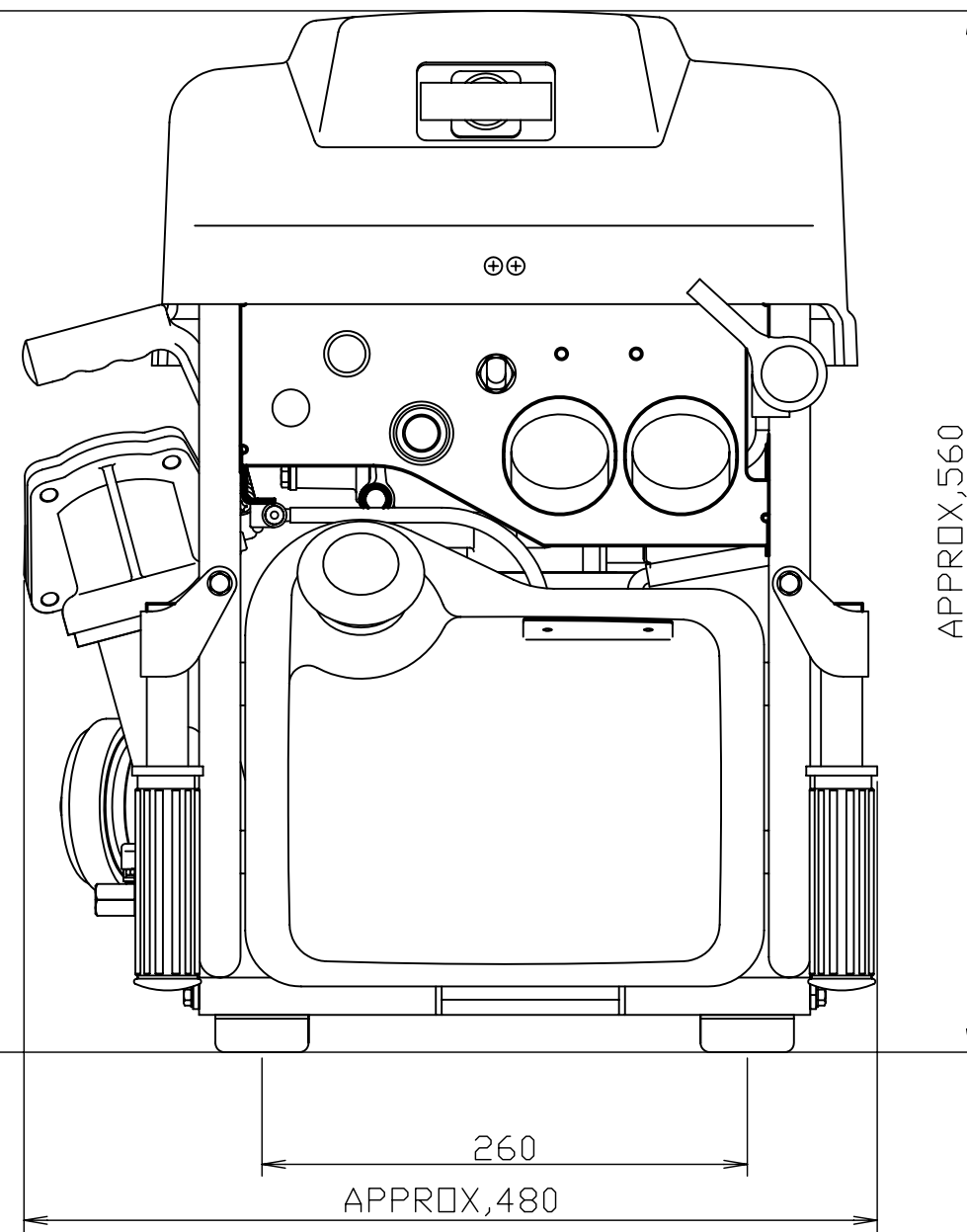
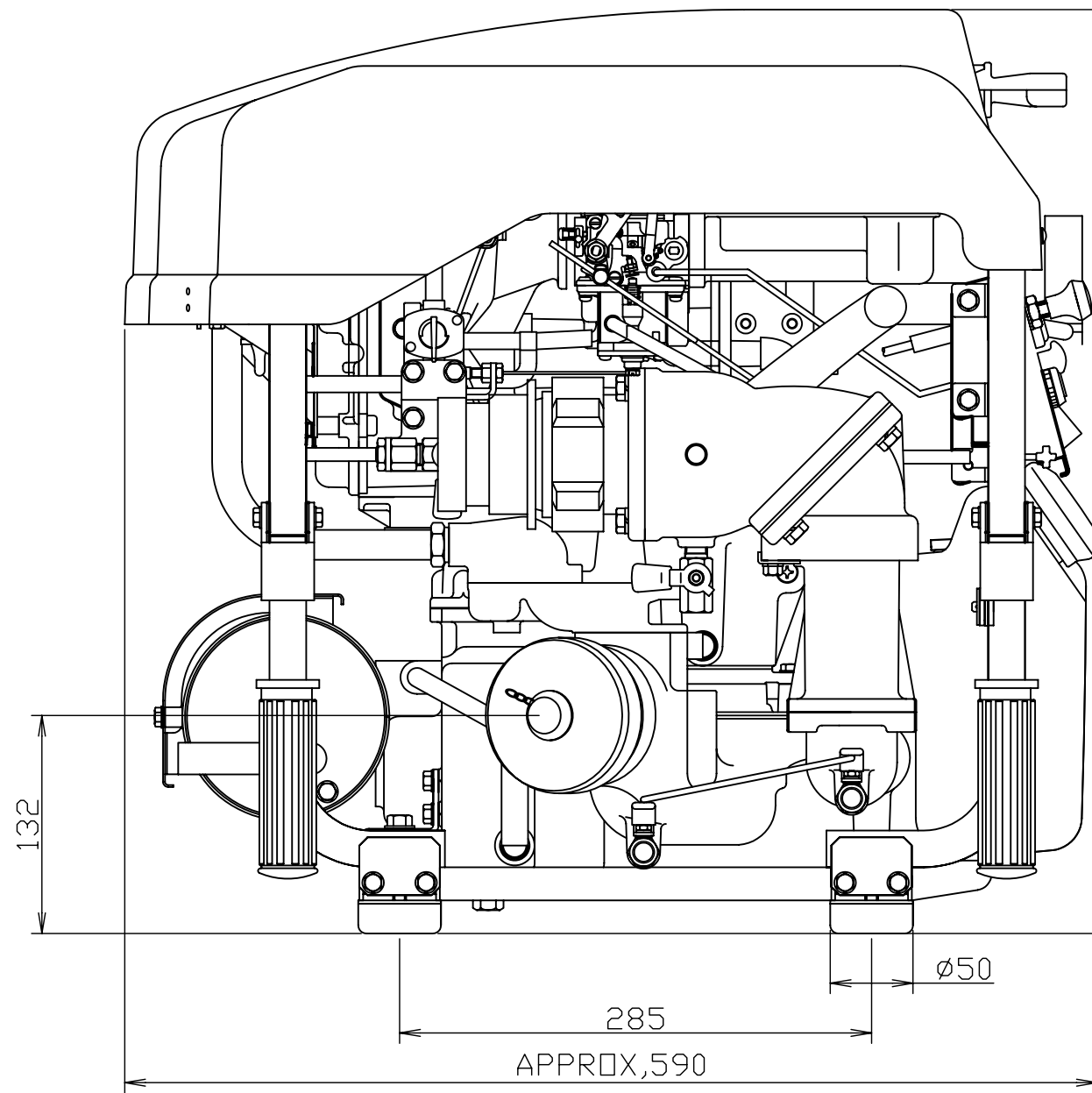

A	Thread of Discharge Port	JIS B-9912 Dimension of Screwed Type Coupling for Fire Hose 2-1/2" x ø82.5 5 Threads Per Inch Angle of Threads 55°	090218	MODEL	VF21A
	吐出側ネジ	W ø82.5 ^{-0.46} _{-0.73} JIS B-9912 消防ネジ結合金具 呼び 65 山 5/吋ネジ 山角度 55°	PART NAME	OUTLINE DRAWING	
B	Thread of Suction Port	JIS B-9912 Dimension of Screwed Type Coupling for Fire Hose 2-1/2" x ø82.5 5 Threads Per Inch Angle of Threads 55°	PART NO.	1P6-80067-000	
	吸水側ネジ	W ø82.5 ^{-0.46} _{-0.73} JIS B-9912 消防ネジ結合金具 呼び 65 山 5/吋ネジ 山角度 55°	TOHATSU		