

OWNER'S MANUAL



Original instructions

EN

EverRun
MX 15E₂
MX 18E₂
OB No.003-11103-ABC1

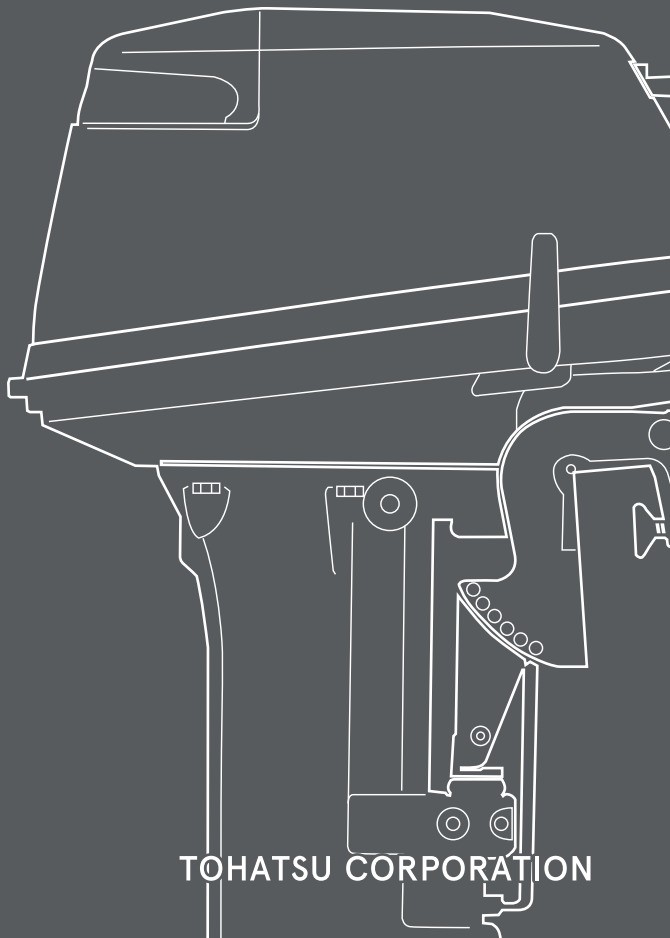

TOHATSU CORPORATION

ENOM00001-0

 **READ THIS MANUAL BEFORE USING THE OUTBOARD MOTOR. FAILURE TO FOLLOW THE INSTRUCTIONS AND SAFETY PRECAUTIONS IN THIS MANUAL CAN RESULT IN SERIOUS INJURY OR DEATH. KEEP THIS MANUAL IN A SAFE LOCATION FOR FUTURE REFERENCE.**

Copyright © 2023 Tohatsu Corporation. All rights reserved. No part of this manual may be reproduced or transmitted in any form or by any means without the express written permission of Tohatsu Corporation.

YOUR TOHATSU OUTBOARD MOTOR

ENOM00006-2

To You, Our Customer

Congratulations on your purchase of the TOHATSU outboard motor. You are now the proud owner of an excellent outboard motor that will serve you for many years to come. This owner's manual contains important safety, operational and maintenance information.

The efficiency and longevity of your outboard motor will depend heavily on your operating methods and periodic maintenance. Failure to operate and maintain your outboard motor according to the instruction in this owner's manual may void the limited warranty, as well as reduce the efficiency and reliability of the outboard motor.

Any person operating TOHATSU outboard motor must carefully read and fully understand the entire contents of this manual prior to operation. For safety, follow all safety warnings contained within the owner's manual and the labels applied to your outboard motor. You should keep this owner's manual where accessible while operating your outboard motor. If the outboard motor is resold, make sure the manual is passed on to the next owner. In case you encounter any problems, please contact an authorized TOHATSU service shop or dealer for assistance.

Tohatsu Corporation reserves the right to change, modify, add, or remove a part or whole of the owner's manual without prior notice and incurring any obligations.

We are excited to take a part in your boating adventures and wish for your great and safe boating experience.

TOHATSU CORPORATION

ENOM00003-1

PRE-DELIVERY INSPECTION

Make sure Pre-delivery inspection has been properly done by authorized TOHATSU dealer before operating your outboard motor.

ENOM00005-1

Serial Number

Your outboard motor has a unique serial number. The serial number is identification of outboard motor and is located on the outboard motor as shown in the figures below. The serial number is required for warranty registration, filing a warranty claim as well as making technical inquiries and may be required for other occasions. Therefore, please write down the serial number and date of purchase in the space below.

Serial Number:

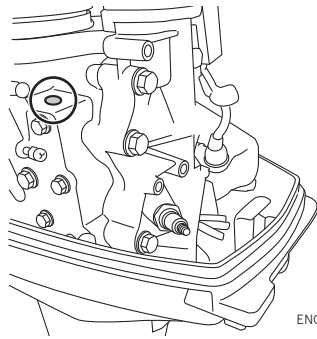
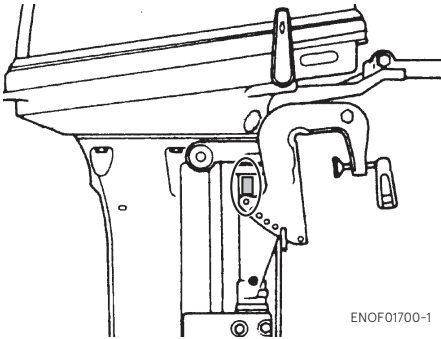

Serial Number:

Date of purchase:

ENOM00007-0

NOTICE: DANGER/WARNING/CAUTION/Note

Before installing, operating or otherwise handling your outboard motor, be sure to thoroughly read and understand this Owner's Manual and carefully follow all of the instructions. Of particular importance is information preceded by the words "DANGER," "WARNING," "CAUTION," and "Note." Always pay special attention to such information to ensure safe operation of the outboard motor at all times.

ENOW00001-0

 **DANGER**

Failure to observe will result in severe personal injury or death, and possibly property damage.

ENOW00002-0

 **WARNING**

Failure to observe could result in severe personal injury or death, or property damage.

ENOW00003-0

 **CAUTION**

Failure to observe could result in personal injury or property damage.

ENON00001-0

Note

This instruction provides special information to facilitate the use or maintenance of the outboard motor or to clarify important points.

CONTENTS

1. GENERAL SAFETY INFORMATION	10
2. SPECIFICATIONS	12
3. PARTS NAME	15
4. LABEL LOCATIONS	17
5. INSTALLATION	20
1. Mounting the outboard motor on boat	20
6. PRE-OPERATING PREPARATIONS	22
1. Fuel handling	22
2. Fuel filling	23
3. Engine oil recommendation	24
4. Break-In	26
7. ENGINE OPERATION	27
Before starting	27
1. Fuel feeding	27
2. Starting the engine	28
3. Warming up the engine	32
4. Forward, reverse, and acceleration	32
5. Stopping the engine	34
6. Steering	35
7. Trim angle	35
8. Tilt up and down	37
9. Shallow water operation	38
8. REMOVING AND CARRYING THE OUTBOARD MOTOR	40
1. Removing the outboard motor	40
2. Carrying the outboard motor	40
3. Traillering	41
9. ADJUSTMENT	43
1. Steering friction	43
2. Throttle grip friction	43
10. INSPECTION AND MAINTENANCE	44
1. Daily Inspection	45
2. Periodic Inspection	49
3. Off-season storage	58
4. Pre-season check	60
5. Submerged outboard motor	61
6. Cold weather precautions	61
7. Striking underwater object	61
8. Auxiliary outboard motor operation	61
11. TROUBLESHOOTING	62
12. TOOL KIT AND SPARE PARTS	64
13. PROPELLER TABLE	65

INDEX

1. GENERAL SAFETY INFORMATION	1
.....	
2. SPECIFICATIONS	2
.....	
3. PARTS NAME	3
.....	
4. LABEL LOCATIONS	4
.....	
5. INSTALLATION	5
.....	
6. PRE-OPERATING PREPARATIONS	6
.....	
7. ENGINE OPERATION	7
.....	
8. REMOVING AND CARRYING THE OUTBOARD MOTOR	8
.....	
9. ADJUSTMENT	9
.....	
10. INSPECTION AND MAINTENANCE	10
.....	
11. TROUBLESHOOTING	11
.....	
12. TOOL KIT AND SPARE PARTS	12
.....	
13. PROPELLER TABLE	13
.....	

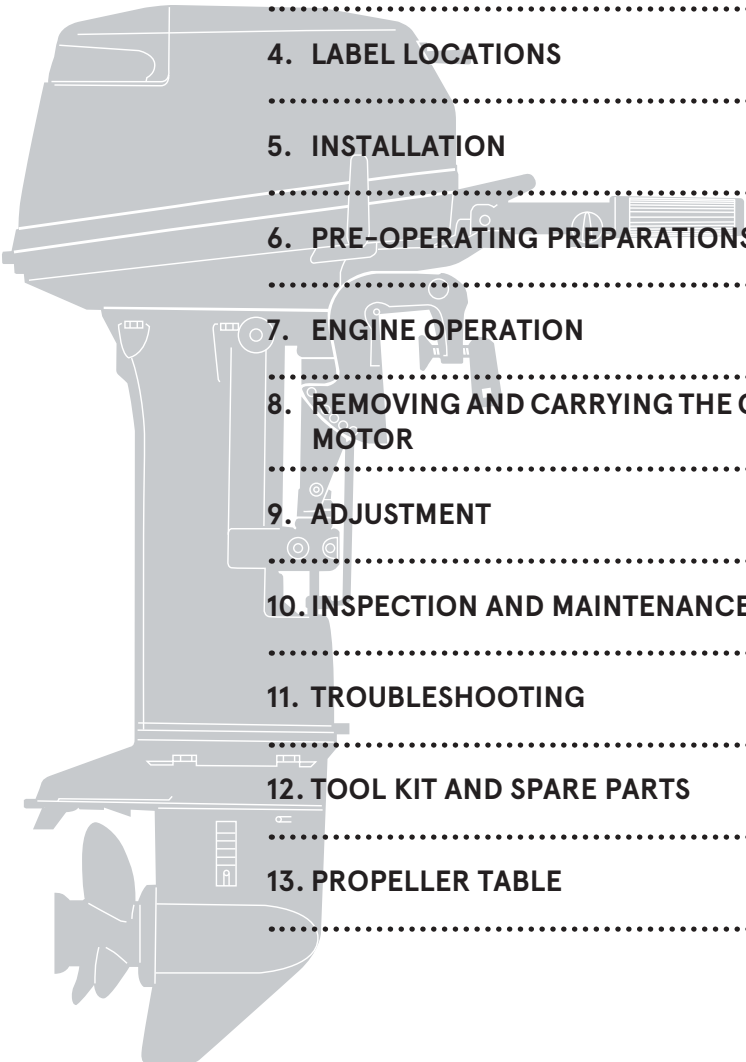

GENERAL SAFETY INFORMATION

1

ENOM00009-1

SAFE OPERATION OF BOAT

As the operator/driver of a boat, you are responsible for the safety of those aboard and those in other boats around yours, and for following local boating regulations. You should be thoroughly knowledgeable on how to correctly operate the boat, outboard motor, and accessories. To learn about the correct operation and maintenance of the outboard motor, please read through this manual carefully.

It is very difficult for a person in the water to take evasive action should he or she see a power boat heading in his/her direction, even at a slow speed.

Therefore, when your boat is in the immediate vicinity of people in the water, the outboard motor must be shifted to neutral and shut off.

ENOW00005-0

WARNING

SERIOUS INJURY IS LIKELY IF A PERSON IN THE WATER MAKES CONTACT WITH A MOVING BOAT, GEAR HOUSING, PROPELLER, OR ANY SOLID DEVICE RIGIDLY ATTACHED TO A BOAT OR GEAR HOUSING.

ENOM00247-1

STOP SWITCH LANYARD

The engine can be stopped by pulling out the stop switch lock from the stop switch. The stop switch lanyard is the coiled red cord with the stop switch lock on one end and a metal clip on the other end. With attaching the stop switch lanyard to the operator's body part or operator's personal flotation device (PFD), the engine will stop when the stop switch lanyard is being stretched and pulled out the lock from the switch if the operator accidentally falls overboard or leaves from operator's position. This function may prevent losing control of the boat and minimize or prevent risk of collision with other boats, people and other objects. It is operator's responsibility to use the stop switch lanyard.

ENOW00004-1

WARNING

Accidental activation of the Stop Switch (such as the tether being pulled out in heavy seas) could cause passengers to lose their balance and even fall overboard, or it could result in loss of power in heavy seas, strong currents, or high winds. Loss of control while mooring is another potential hazard.

To minimize accidental activation of the Stop Switch, the 500 mm (20 inch.) stop switch lanyard is coiled and can be extended to a full 1300 mm (51 inch.).

ENOM00800-A

PERSONAL FLOTATION DEVICE

As the operator/driver and passenger of a boat, you are responsible to wear a PFD (Personal Flotation Device) while on the boat.

ENOM00010-1

SERVICING, REPLACEMENT PARTS & LUBRICANTS

We recommend that only an authorized service shop perform service or maintenance on your outboard motor. Be sure to use genuine parts, genuine lubricants, or recommended lubricants. Be aware that the installation and use of parts not approved by Tohatsu Corporation will void warranty and may lead to unsafe operating conditions.

ENOM00011-1

MAINTENANCE

As the owner of the outboard motor, you should be acquainted with correct maintenance procedures following by maintenance section of this manual (See page 44). It is the operator's responsibility to perform all safety inspections, proper lubrication and to follow all maintenance instructions for safe operation. You should take the engine to an authorized dealer or service shop for periodic inspection at the prescribed intervals. Correct periodic maintenance and proper care of outboard motor will reduce the chance of problems, limit overall operating expenses and contribute to longevity of your outboard motor.

Carbon Monoxide Poisoning Hazard

Exhaust gas contains carbon monoxide, a colorless and odorless gas which can be fatal if inhaled for any length of time.

Never start or operate the engine indoors or in any space which is not well ventilated.

Gasoline

Gasoline and its vapors are very flammable and can be explosive. Use extreme care when handling gasoline. You should be thoroughly knowledgeable on how to correctly handle gasoline by reading this manual.

SPECIFICATIONS

ENOM00810-B

MODEL FEATURE

2

Model		MX15E2	MX18E2
Type		MF	MF
Transom heights	S	●	●
	L	●	●
	UL		●
Tiller Handle		●	●
Remote Control		(●)*1	(●)*1
Power Tilt			
Gas-assisted tilt			
Manual tilt		●	●

*1: Option

ENOM00811-B

MODEL NAME EXAMPLE

MX18E2MFL

MX	18	E	2	M	F	L
Model description	Horse power	Product generation	Minor change	Starter system	Steering system	Shaft length
M(X) = Two stroke	-	A and up	2 and up	E = Electrical start M = Manual start	P = Remote control F = Tiller handle	S = Short 15 in L = Long 20 in UL = Ultra long 25 in

ENOM01000-0

X15/18E2MF

2

Item	Model	MX 15/18E2
		MF
Overall Length	mm (in)	869 (34.2)
Overall Width	mm (in)	345(13.6)
Overall Height	S mm (in)	1067 (42.0)
	L mm (in)	1194 (47.0)
	UL mm (in)	1321 (52.0)
Transom Height	S mm (in)	435 (17.1)
	L mm (in)	562 (22.1)
	UL mm(in)	689 (27.1)
Weight*1	S kg (lb)	41 (90)
	L kg (lb)	42 (93)
	UL kg (lb)	43 (95)
Engine Type		2 stroke
Number of Cylinder		2
Piston Displacement	cm ³ (Cu.in.)	294 (17.94)
Bore x Stroke	mm (in)	60 x 52 (2.36 x2.05)
Max. Output	kW (PS)	11.0 (15) 13.2 (18)
Max. Operating Range	min ⁻¹ (rpm)	MX15E2 : 4500 - 5500 MX18E2 : 5200 - 5800
Idle Speed in Forward Gear	min ⁻¹ (rpm)	800
Idle Speed in Neutral Gear	min ⁻¹ (rpm)	950
Exhaust System		Through hub exhaust
Lubrication System		Gasoline oil mixed type
Cooling System		Water cooling (with thermostat)
Starting System		Manual starter
Ignition System		Flywheel Magneto CD Ignition
Steering Angle	Degree	80
Trim Angle*2	Degree	-7 - 13
Trim Position		6
Tilt Up Angle*2	Degree	58
Gear Shift		Dog clutch (F-N-R)
Gear Reduction Ratio		1.85 (24:13)

Remark: Specifications subject to change without notice.

*1 With propeller.

*2 Transom angle is at -12°

Tohatsu outboard is power rated in accordance with ISO8665 (propeller shaft output).

Service data

Item		Model	MX 15/18E2
			MF
Fuel			Unleaded Regular Gasoline : R+M/2: 87 or higher RON: 91 or higher
Fuel Tank Capacity		L (US gal)	25 (6.60) Separate
Engine Oil		Grade	Genuine two stroke engine oil or NMMA certified TC-W3 outboard oil
Engine Oil Mixing Ratio			Unleaded Gasoline 50 : Genuine 2-stroke Engine Oil 1
Gear Oil		Grade	API:GL-5, SAE:80-90
		mL (US/Imp.oz)	370 (12.5/13.0)
Battery (minimum requirements)			-
Spark Plug			NGK BP7HS-10 or BPR7HS-10
Spark Plug Gap		mm (in)	0.9-1.0 (0.035-0.039)

Tightening torque

Gear Oil Plug	4N · m (3ft · lb, 0.4kgf · m)
Propeller Nut	25N · m (18ft · lb, 2.5kgf · m)
Spark Plug	27N · m (20ft · lb, 2.7kgf · m)

PARTS NAME

ENOM00820-0

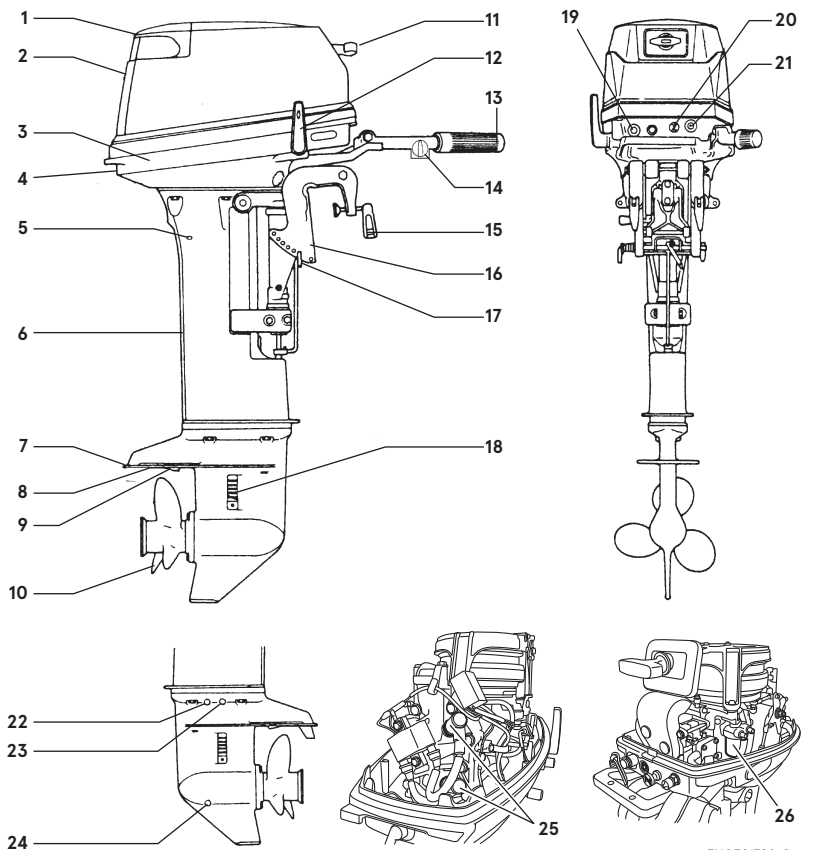
MF

- | | | |
|----------------------------|----------------------------|--------------------------|
| 1 Tilt Handle | 11 Starter Handle | 21 Fuel Connector (Male) |
| 2 Top Cowl | 12 Shift Lever | 22 Oil Plug (Upper) |
| 3 Bottom Cowl | 13 Throttle Grip | 23 Water Plug |
| 4 Cowl Hook Lever | 14 Throttle Friction Screw | 24 Oil Plug (Lower) |
| 5 Cooling Water Check Port | 15 Clamp Screw | 25 Spark Plug |
| 6 Drive Shaft Housing | 16 Clamp Bracket | 26 Fuel Filter |
| 7 Anti-Ventilation Plate | 17 Thrust Rod | |
| 8 Anode | 18 Water Inlet | |
| 9 Sub-Water Inlet | 19 Stop Switch | |
| 10 Propeller | 20 Choke Knob | |

ENOF01702-0

ENOM00822-0

Fuel tank

3

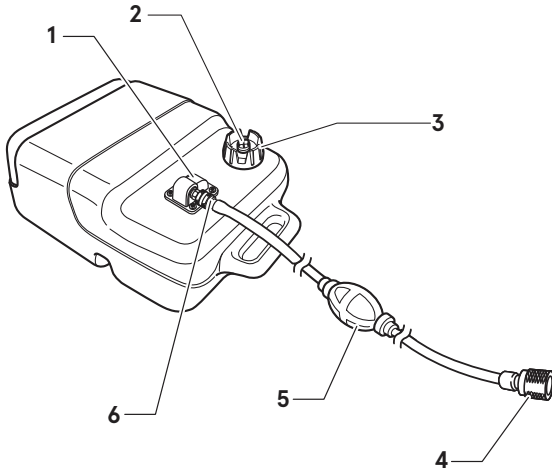

ENOF00127-F3

- 1 Fuel Gauge
- 2 Air Vent Screw
- 3 Fuel Tank Cap
- 4 Fuel Connector (Engine side)
- 5 Primer Bulb
- 6 Fuel Connector (Fuel tank side)

LABEL LOCATIONS

ENOM00019-A

Warning label locations

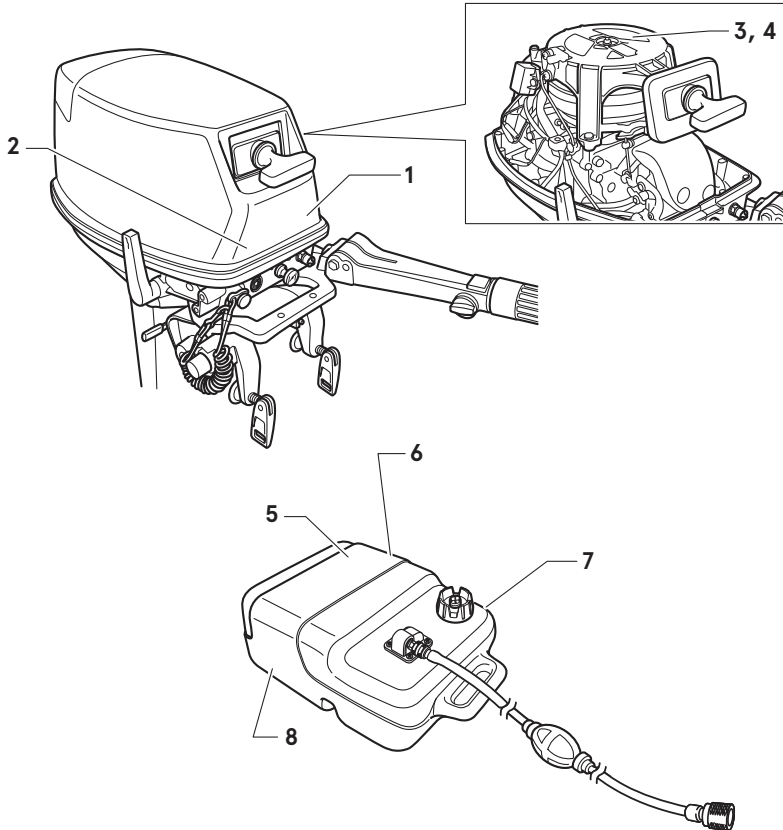

4

1, 3. Read owner's manual.

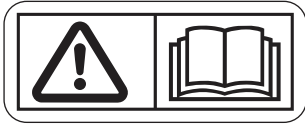

3FOX72185-0

2. Engine stop switch (See page 35).



ENOF00131-B

4. HOT SURFACE

Can cause burns.

Do not touch when operating or immediately after the engine has stopped.

ELECTRICAL SHOCK HAZARD

High voltage can cause severe electrical shock.

Do not touch electrical components such as ignition coil or spark plug cord when starting or while the engine is in operation.

HAZARD CAUSED BY ROTATING PARTS

Rotating parts can cause severe injury.

Keep hands, feet, hair, and clothing away from all rotating parts to prevent injury.



314X72185-0

5. Warning regarding gasoline.

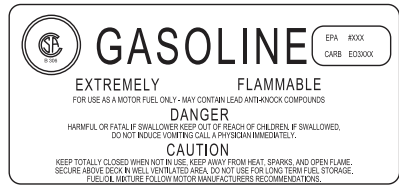

ENOF00005-E

6. Warning regarding gasoline (See page 22).



ENOF00005-L

7. Warning regarding gasoline (See page 22).



ENOF00005-M

8. Warning regarding gasoline (See page 22).



ENOF00005-F

ENOM01001-0

Serial number label locations

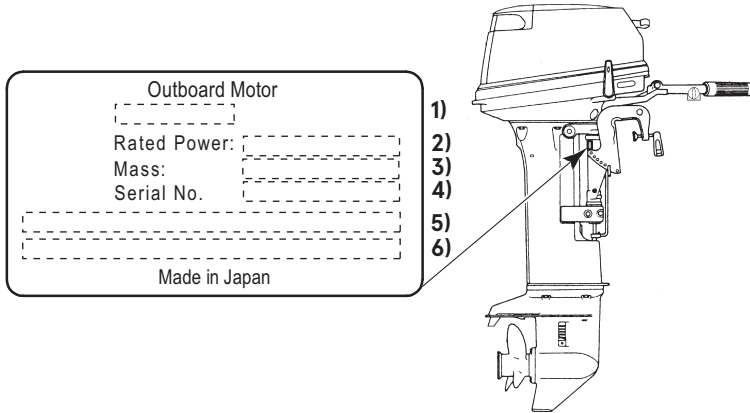

4

ENOF01704-A

1. Model code (Model name)
2. Rated power
3. Dry mass weight
4. Serial No.
5. Manufacture name
6. Manufacture address

Description of serial number year code

Last two digits of alphabet represent production year as below.

Year Code	BC	BD	BE	BF	BG
Year of manufacture	2023	2024	2025	2026	2027

INSTALLATION

ENOM00024-B

1. Mounting the outboard motor on boat

ENOW00006-1

WARNING

Most boats are rated and certified for their maximum allowable horsepower, as shown on the boat's certification plate. Do not equip your boat with an outboard motor that exceeds this limit. If in doubt, contact your dealer.

Do not operate the outboard motor until it has been securely mounted on the boat in accordance with the instructions below.

5

ENOW00009-2B

WARNING

- Mounting the outboard motor without following this manual can lead to unsafe conditions such as poor maneuverability, lack of control or fire.
- Loose clamp screws and/or mounting hardware can lead to the release or displacement of the outboard motor, possibly resulting in loss of control and/or serious personal injury. Check the fasteners for tightness before operating your outboard.
- Be sure to use outboard mounting hardware that meet in terms of size, material, quality and strength.

Keep the outboard motor in a vertical position when mounting.



ENOF01705-0

ENOM00025-B

Position ... Above keel line

Place the outboard motor in the center of the boat's transom.

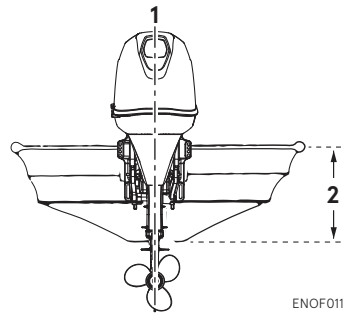

ENOF01141-0

1. Center of boat
2. Boat transom

ENOM00026-0

Transom matching

Be sure that the anti ventilation plate of the outboard motor is 30–50 mm (1.2–2 in) below the bottom of hull.

If the above condition cannot be met due to the shape of the bottom of your boat, please consult your authorized dealer.

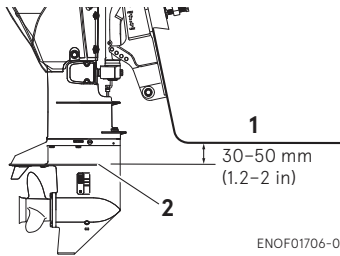

1. Bottom of hull
2. Anti ventilation plate

ENOW00007-1

CAUTION

- Before running test, check the boat with maximum loading capacity. Overloading or incorrect weight distribution of the weight may result in boat to lose control, even swamping or capsizing. Make sure that there is enough distance between bottom cowl and water surface to prevent water from entering the engine.
- Make sure to mount the engine in correct position. If outboard motor is mounted incorrectly, water may intrude the engine from openings of the bottom cowl while cruising. Exposing the engine to such condition may result in severe damage to the engine.

ENOM00832-D

Mounting the outboard motor

1. Set the outboard motor to appropriate position.
2. Tighten the clamp screws by turning their handles.
3. Secure the clamp brackets to the transom board using bolts, flat washers and nylon locking nuts.
4. Secure the outboard motor to the boat with a rope to prevent accidental loss of the outboard motor overboard.

ENON00930-1

Note

- Do not use tools to tighten clamp screws. Over tightening could result in damage to the clamp screws and clamp brackets.
- Do not reuse Nylon locking nut.

ENON00002-1

Note

Mounting hardware and rope are not included in the standard accessories.

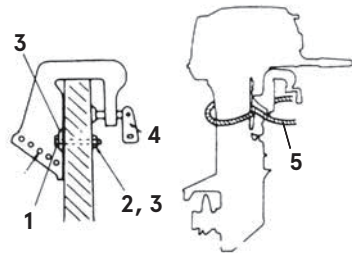

1. Bolt (8 × 85)
2. Nylon locking nut
3. Washer
4. Clamp screw
5. Rope

ENON00003-B

Note

Apply sealing agent, such as silicone sealed between the bolts and the transom board holes before tightening the bolts.

PRE-OPERATING PREPARATIONS

ENOM00030-A

1. Fuel handling

ENOW000017-0

CAUTION

Use of improper gasoline can damage your engine. Engine damage resulting from the use of improper gasoline is considered misuse of the engine, and damage caused thereby will not be covered under the limited warranty.

ENOM00031-1

FUEL RATING

Use only major brand unleaded fuel meeting the following specifications:

USA and Canada – having a posted pump Octane Rating of 87 (R+M)/2 minimum. Premium gasoline (92 [R+M]/2 Octane) is also acceptable. Do not use leaded gasoline.

Outside USA and Canada – Use unleaded gasoline with declared octane rating of 91 RON or over. Use of premium gasoline of 98 RON is also allowed.

ENOM00032-1

GASOLINES CONTAINING ETHANOL

The fuel system components on your TOHATSU outboard motor will withstand up to 10% ethyl alcohol (hereinafter referred to as the "ethanol") content in the gasoline. If the gasoline in your area contains ethanol, be aware of certain adverse effects that can occur. Increasing the percentage of ethanol in the fuel can also worsen these adverse effects. Some of these adverse effects are caused by ethanol absorbing moisture in

the air, which leads to separation of the water/ethanol from the gasoline in the fuel tank.

Use of gasoline containing ethanol may accelerate:

- Corrosion of metal parts
- Deterioration of rubber or plastic parts
- Fuel permeation through rubber fuel lines
- Starting and operating difficulties

If the use of gasoline containing ethanol cannot be avoided or presence of ethanol is suspected in the gasoline, it is recommended to use a filter to separate water, and frequently check the fuel system for leaks, mechanical parts for corrosion and abnormal wear.

In case any of such abnormality is found, discontinue the use of such gasoline and contact our dealer immediately.

If the outboard motor will only be used infrequently, please see the remarks on fuel deterioration in the STORAGE chapter (P 58) for additional information.

ENOW00975-0

CAUTION

When operating an outboard motor with gasoline containing ethanol, storing gasoline in the fuel tank for long periods should be avoided. Storing gasoline for long periods creates unique problems. In cars, ethanol blended fuels are normally consumed before they can absorb enough moisture to cause problems, but boats often sit idle long enough for separation phase to take place. In addition, internal corrosion may take place during storage if ethanol washes away the oil films protecting internal components.

ENOW00018-1

⚠ WARNING

Fuel leakage can cause fire or explosion, potentially leading to severe injury or loss of life. Every part of fuel system should be inspected periodically. Inspect for fuel leak, hardness or any alteration of rubber, expansion and/or corrosion of metals especially after long term storage. In case any indication of fuel leakage or degradation in fuel system is found, replace the part immediately before using the outboard motor.

ENOM00043-B

2. Fuel filling

ENOW00976-0

⚠ WARNING

Do not fill the fuel tank over capacity. Under high temperature conditions, excessive gasoline may evaporate/leak through air vent screw when it is loose or open. Leaking of gasoline is a may lead to a dangerous fire hazard.

ENOW00028-1

⚠ WARNING

Consult an authorized dealer for details on handling gasoline, if necessary.

Gasoline and its vapor are very flammable and can be explosive.

When carrying a fuel tank containing gasoline:

- Close the fuel tank cap and air vent screw of fuel tank cap, or gasoline may evaporate through the air vent screw and may lead to a fire hazard.
- Do not smoke.

When or before refueling:

- Be sure to remove the static electricity charged in your body before refueling.

- The static electricity may ignite the gasoline vapor during refueling.
- Stop the engine, and do not start the engine during refueling.
- Do not smoke.
- Be careful not to overfill fuel tank. Wipe up any spilled gasoline immediately.

When or before cleaning the gasoline tank:

- Dismount fuel tank from the boat.
- Place the fuel tank away from every source of ignition, such as sparks or open flames.
- Do the work outdoors or in a well ventilated area.
- Wipe up gasoline well immediately if spilled.

After cleaning gasoline tank:

- Wipe up gasoline well immediately if spilled.
- If the fuel tank is disassembled for cleaning, reassemble carefully. Incorrect assembly may cause a fuel leak, possibly leading to fire or explosion.
- Dispose aged or contaminated gasoline in accordance with local regulations.

ENOW00029-1

⚠ WARNING

When opening fuel tank cap, be sure to follow the procedure described below. Fuel could blast out if the fuel tank cap is opened by using another procedure when internal pressure of fuel tank is raised by heat from sources such as sun light.

1. Fully open the air vent screw on the fuel tank cap and release internal pressure.

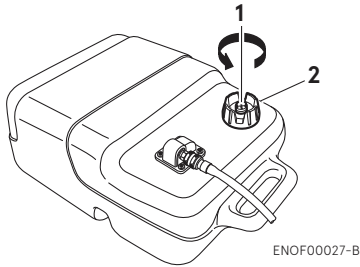

1. Air vent screw
2. Fuel tank cap

6

2. Open the fuel tank cap slowly.
3. Fill the fuel carefully not to overflow.

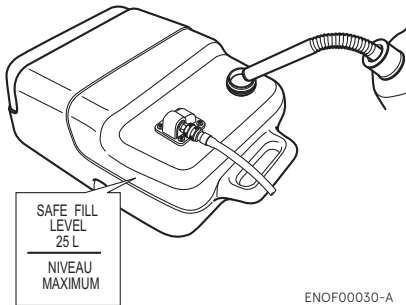

4. After filling the tank, close the fuel tank cap.

ENOM01002-0

3. Engine oil recommendation

ENOW0002A-A

! CAUTION

Use of engine oils that do not meet these requirements will result in reduced engine life, and other engine problems.

Use a genuine two stroke engine oil or ones recommended (TC-W3). Refer to your Distributor.

Use of other two stroke engine oil is not recommended.

Add engine oil into fuel tank. The mixing ratio of gasoline and oil is 50:1. Make sure that gasoline and oil are mixed well. The mixing ratio during break in is 25:1.

Mixing Ratio

	Gasoline : Engine Oil
During break-in	25 : 1
After break-in	50 : 1

Fuel by Oil Mixing (25:1, 50:1)

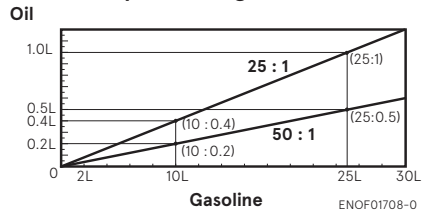

ENOM01003-0

Engine oil – gasoline mixing procedure

ENOW00937-1

! CAUTION

- Do not use other than two stroke engine oil with specified grade, or the engine may be damaged.
- Do not use fuel prepared in other than specified mixing ratio.
 - Lack of engine oil can cause severe engine problems such as piston seizure.
 - Excess of engine oil can shorten spark plug life, and/or cause increase of noxious exhaust.

For engine oil and gasoline mixing ratio, refer to table in previous page.

■ **When portable fuel tank is used for operation of outboard motor(s):**

- 1 Pour engine oil into fuel tank, and then, gasoline.
- 2 Put cap on the tank, and close tightly.
- 3 Close air vent plug tightly.

ENOW00938-0

⚠ WARNING

Loose cap or air vent plug can cause leak of fuel.

- 4 Shake the tank to mix engine oil and gasoline well.

■ **For boat with built in fuel tank:**

- 1 Prepare separate fuel container for pre-mixing.

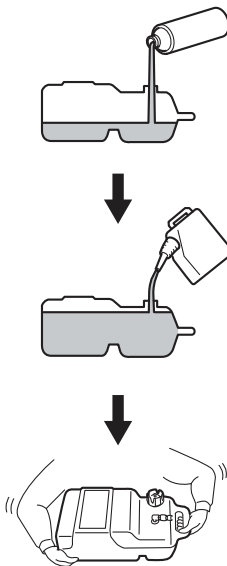

ENOF01709-0

- 2 Pour engine oil into fuel container, and then, gasoline.
- 3 Put cap on the container, and close tightly.
- 4 Shake the container to mix engine oil and gasoline well.
- 5 Pour the fuel into fuel tank.

ENON00922-1

Notes

- It is recommended to pre-mix by using separate fuel container. Avoid mixing the oil and gasoline in the built in fuel tank on the boat.
- If mixing in built-in fuel tank on the boat, allow it to mix well by pouring engine oil into the tank little by little while pouring gasoline into the tank.

ENOM00033-B

4. Break-In

Your new outboard motor and lower unit require break-in for the moving components according to the conditions described in the following timetable.

ENOW00024-1

DANGER

Do not operate the outboard motor in closed area or area with not enough ventilation.

Exhaust gas emitted by the outboard motor contains carbon monoxide that may cause dizziness, nausea, other health problem or even death if inhaled continuously.

During operation of the outboard motor:

- **Keep peripheral area well ventilated.**
- **Always stay on the windward side of emission.**

ENOW00023-1

CAUTION

Operating the outboard motor without break-in can shorten life of the product.

If any abnormality is experienced during the break-in:

- **Discontinue the operation immediately.**
- **Have the dealer check the product and take proper action(s) if necessary.**

ENOM01004-0

Fuel mix ratio for break-in

Gasoline 25: Genuine Engine Oil 1

ENON00008-2

Note

- During Break-in, run the outboard motor at varied RPM less than specified engine speed. Not following the procedure may result in problems and may shorten the product life.
- Break-in must be conducted under load in the water in-gear with propeller installed.

6

	1-10 min	10 min - 2 hrs	2-3 hrs	3-10 hrs	After 10 hrs
Throttle Position	Idle	Less than 1/2 throttle	Less than 3/4 throttle	3/4 throttle	Full throttle available
Speed		Approx. 3000 min ⁻¹ (rpm) max	Full throttle run allowed for 1 min every 10 min	Approx. 4000 min ⁻¹ (rpm). Full throttle run allowed for 2 min every 10 min	

ENGINE OPERATION

ENOM00042-0

Before starting

ENOW00022-B

CAUTION

Be sure to fill the engine before starting engine. (To properly fill the engine with oil follow the instructions. See page 24)

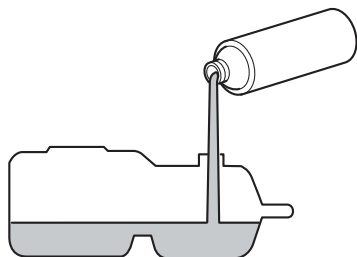

ENOF01710-0

ENOM00044-E

1. Fuel feeding

ENOW00029-1

WARNING

When opening fuel tank cap, be sure to follow the procedure described below. Fuel could blast out if the fuel tank cap is opened by using another procedure when internal pressure of fuel tank is raised by heat from sources such as sun light.

1. Fully open the air vent screw on the fuel tank cap.

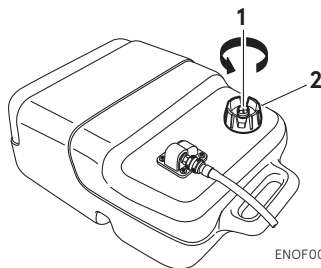

ENOF00027-B

1. Air vent screw
 2. Fuel tank cap
2. Open the fuel tank cap slowly and release internal pressure completely. After that, close the fuel tank.
 3. Connect the fuel connector to the engine and fuel tank.

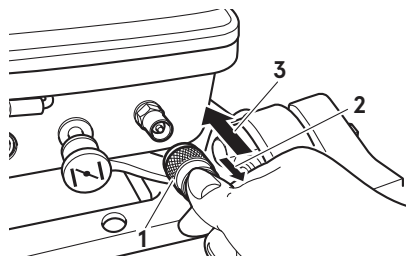

ENOF01711-0

1. Fuel connector
2. Push
3. Insert

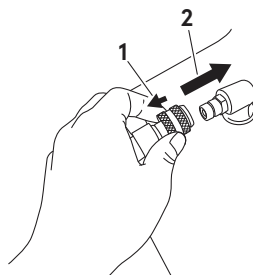

ENOF00861-A

1. Pull
2. Insert

- Squeeze primer bulb until it becomes stiff to feed fuel to carburetor. Point the arrow mark upward when priming.



ENOF00862-0

- Engine side
- Fuel tank side

Do not squeeze primer bulb with engine running or when the outboard motor is tilted up. Otherwise, fuel could overflow.

ENOW00045-A

2. Starting the engine

ENOW00958-1

! WARNING

- Do not remove or install the top cowl after the engine has started.
- The exposed rotating engine parts cause serious injury.

ENOW00959-0

! CAUTION

The top cowl must be installed while the engine running except in an emergency. If the top cowl is not installed correctly, water splash can damage the engine.

ENOW00036-1A

! CAUTION

When starting the outboard motor in the test tank, make sure that:

- Water level is at least 10 cm (4 in.) above the anti-ventilation plate to avoid overheating of the engine.

- Run at idling only
- Remove the propeller (See page 53)

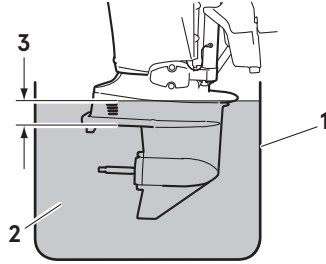

ENOF00863-0

- Test tank
- Water
- Over 10 cm (4 in.)

ENOW00036-1

! CAUTION

Operating outboard motor without cooling water will lead to overheating and damage on the outboard motor severely. In case the cooling water check port is not discharging water, stop the outboard motor immediately, check for any object, debris which may be blocking the cooling water check port. If you are unable to locate the cause, consult an authorized dealer immediately.

This model is provided with start in gear protection.

ENON00010-1

Note

Start-in-gear protection prevents the engine from starting at other than neutral shift. In-gear starting of engine will move the boat immediately, potentially leading to fall down or causing passenger(s) to be thrown overboard.

ENOM01005-C

Tiller handle type

1. Be sure to install the stop switch lock to the stop switch, and attach the stop switch lanyard securely to the operator or to the operator's PFD (Personal Flotation Device.)

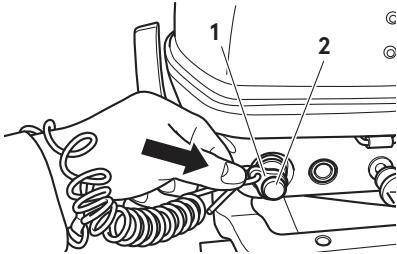

ENOF01712-0

1. Stop switch lock
 2. Stop switch
2. Set the shift lever in the Neutral position.

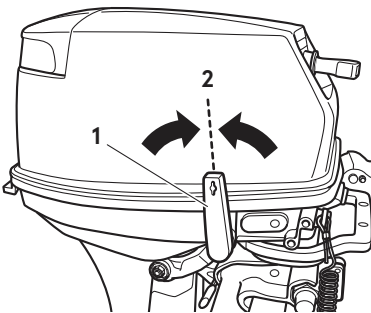

ENOF01713-0

1. Shift lever
2. Neutral

3. Set the throttle grip to START position.

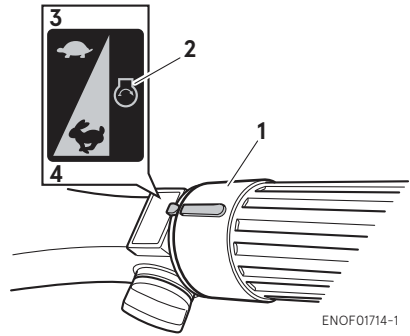

ENOF01714-1

1. Throttle grip
2. START position
3. Fully closed
4. Fully opened

4. Pull the choke knob fully.

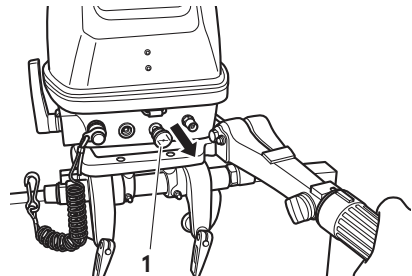

ENOF01740-0

1. Choke knob

(For manual starter type)

This engine is equipped with a compression release mechanism.

- Pull the starter handle slowly until you feel engagement, keep pulling till you feel less resistance. Then pull it quickly. Repeat the procedure until the outboard motor is started.

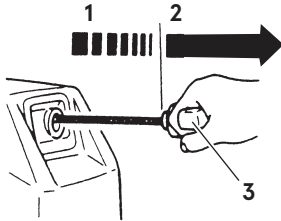

ENOF00519-0

- Slowly
- Quickly
- Starter handle

- Return the choke knob fully after engine has started.
- Make sure that water is being discharged from the cooling water check port.

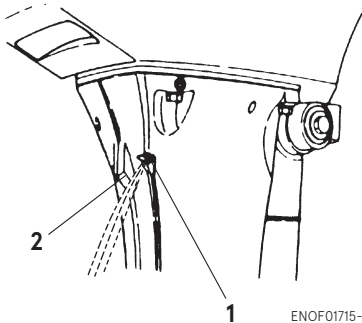

ENOF01715-0

- Cooling water check port
- Idle port

ENOM00042-F

Emergency starting

ENOW00099-1



When the emergency starter rope is used for starting engine;

- Start in gear protection does not work. Make sure that shift is in neutral position. If the gear is in Forward or Reverse, the boat can start moving immediately and may lead to accident and personal injury.
- Be careful that of your clothes or other items do not to get caught in the rotating parts.
- To prevent accident and injury by rotating parts, do not re-attach flywheel cover or recoil starter and the top cowl after the engine has been started.
- Do not pull starter rope if any bystander is around.
- Attach engine stop switch lanyard to clothing or any part of body such as wrist, arm before starting engine the outboard motor.

- Remove the top cowl.

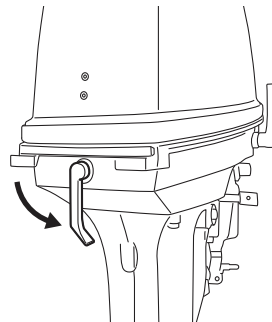

ENOF01716-0

2. Disconnect the linkage of the starter lock rod.

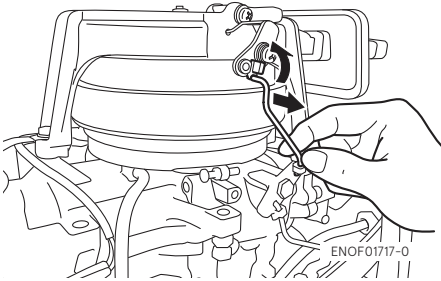

3. Remove the bolts (3pcs) and remove the recoil starter.

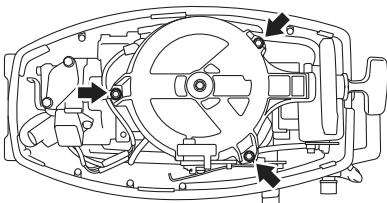

4. Insert the knotted end of the starter rope into the notch in the flywheel and wind the rope clockwise around the flywheel several turns.

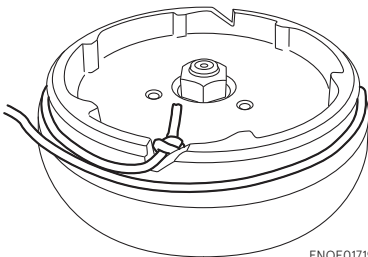

5. Tie a loop to the other end of the emergency starter rope and attach socket wrench that is included in the tool kit.

ENOW00860-0

CAUTION

Be sure to keep the harness away from the rotation parts.

6. Be sure to install the stop switch lock to the stop switch, and attach the stop switch lanyard securely to the operator or to the operator's PFD (Personal Flotation Device.)
7. Set the shift lever in the Neutral position.
8. Pull the starter handle slowly until you feel engagement, keep pulling till you feel less resistance, then pull it quickly.

7

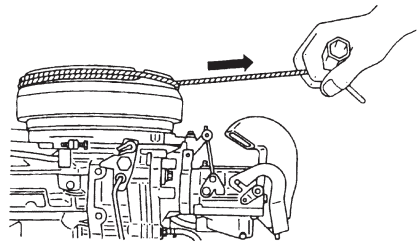

9. Once the outboard motor is started, do not reinstall recoil starter and top cowl.

ENOM00043-A

3. Warming up the engine

ENOW00932-1

CAUTION

Be sure to check that cooling water is discharged from the cooling water check port during warm up.

Warm the engine at low engine speeds for about

3 minutes : above 5°C (41°F)

5 minutes at 2000 min⁻¹ (rpm) :
above 5°C (41°F)

This allows the lubricating oil to circulate to all parts of the engine. Operating the engine without warm up shortens the engine's life.

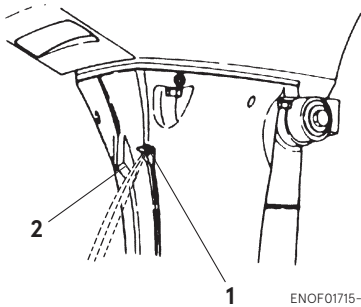

1. Cooling water check port
2. Idle port

ENOM00044-A

Engine speeds

Idle speed after warming up.

Trolling speed (In Forward)	Idling speed (in Neutral)
800 min ⁻¹ (rpm)	950 min ⁻¹ (rpm)

ENOM00046-A

4. Forward, reverse, and acceleration

ENOW00037-1

WARNING

Before shifting into forward or reverse, make sure that boat is properly moored and out-board motor can be steered fully to the right and left. Make sure that no swimmer(s) is around of the boat.

ENOW00967-0

WARNING

- Attach other end of emergency stop switch lanyard to the operator's PFD (Personal Flotation device) or arm and keep it attached during cruising.
- Do not attach the lanyard to a part of clothing that can be torn easily when pulled.
- Arrange the lanyard so that will not be caught by any object when pulled.
- Be careful not to pull the lanyard accidentally during cruising. Unintentional stop of engine can cause loss of control of out-board motor. Rapid loss of engine power can lead to falling down or causing passenger(s) to be thrown overboard.

ENOW00042-1

WARNING

- Do not shift into Reverse during planing, or control will be lost leading to serious personal injury, boat may swamp, and/or hull may be damaged.
- Do not shift into Reverse during cruising, or control may be lost, fall down or causing passenger(s) to be thrown overboard. Leading to serious personal injury, and steering system and/or shifting mechanism may be damaged.

ENOW00861-1

⚠ WARNING

Do not shift at high boat speed, or control may be lost, fall down or causing passenger(s) to be thrown overboard. Leading to serious personal injury.

ENOW00862-1

⚠ WARNING

Sudden acceleration and deceleration may cause passenger(s) to be thrown overboard or fall down.

ENOW00862-1

⚠ CAUTION

Gear and clutch damage may occur if shifting at high engine speed.

Engine must be in the slow idle position before shifting.

ENOW00863-0

⚠ CAUTION

Idle speed may be higher during warming up of engine. If shifted to Forward or Reverse during warming up, it may be difficult to shift back to neutral. In such case, stop engine, shift to neutral, and restart engine to warm up.

ENON00014-0

Note

Frequent shifting to forward or reverse can accelerate wear or degradation of parts. In such case, replace gear oil earlier than the period specified.

ENOW00864-0

⚠ CAUTION

Do not increase engine speed unnecessarily when the shift is in neutral and reverse, or engine damage may occur.

ENOM00890-A

Tiller handle type

ENOW00865-A

⚠ CAUTION

Do not force to shift when the throttle grip is not in the fully closed position, otherwise, steering system and/or shifting mechanism may be damaged.

Forward

1. Turn the throttle grip to reduce engine speed.
2. When the engine reaches trolling (or idling) speed, quickly pull the shift lever to the Forward position.

Reverse

1. Turn the throttle grip to reduce engine speed.
2. When the engine reaches trolling (or idling) speed, quickly pull the shift lever to the Reverse position.

Acceleration

Open throttle grip gradually.

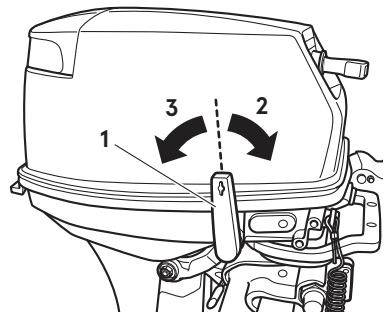

ENOF01721-0

1. Shift lever
2. Forward
3. Reverse

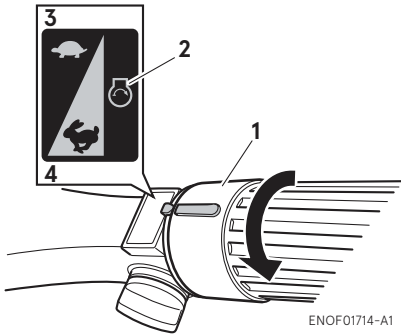

- 1. Throttle grip
- 2. START position
- 3. Full closed
- 4. Full opened

ENOM00049-A

5. Stopping the engine

ENOW00868-1

WARNING

Be careful not to remove engine stop switch lanyard from engine accidentally while boat is running. Sudden stop of engine can cause loss of steering control, speed, possibly leading the crew(s) and or objects on the boat to be thrown forward due to inertial force.

Tiller handle type

1. Turn the throttle grip to the slow position.

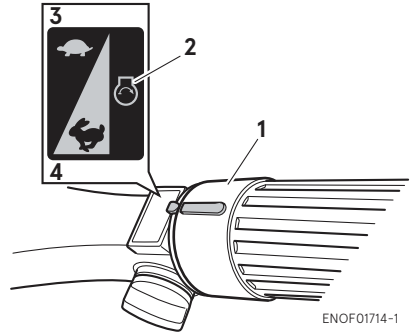

- 1. Throttle grip
- 2. START position
- 3. Fully closed
- 4. Fully opened

2. Put the shift lever in the Neutral position.
Run the engine for 2-3 minutes at idling speed for cooling down if it has been running at full speed.
3. Push the stop switch for a few seconds to stop the engine.

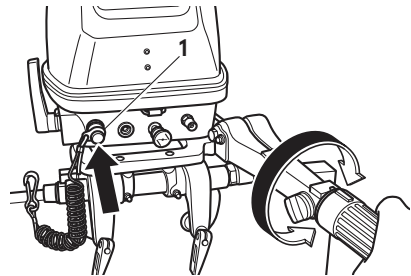

- 1. Stop switch

ENOF01722-0

ENOW00869-1

WARNING

After stopping the engine:

- Close the air vent screw on the fuel tank cap.
- Disconnect the fuel connector from the engine and the fuel tank.
- Disconnect the battery cable, after each use.

Emergency engine stopping

Remove stop switch lock to stop the engine.

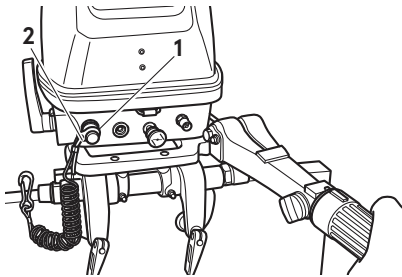

ENOF01723-0

1. Stop switch
2. Stop switch lock

ENOM00910-1

Spare emergency stop switch lock

A spare emergency stop switch lock is provided in the accessories bag.

Make sure that spare stop switch lock is available before operating outboard motor.

When used as described, the emergency stop switch clip and emergency stop switch lanyard system stops the engine if the operator is thrown overboard. When an operator falls into water, be sure to use spare emergency stop switch lock.

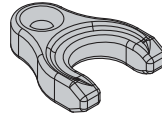

ENOF00891-0

ENOM00920-0

6. Steering**WARNING**

Sudden steering may cause passenger(s) to be thrown overboard or fall.

Tiller handle type**Right turn**

Move the tiller handle to the left

Left turn

Move the tiller handle to the right.

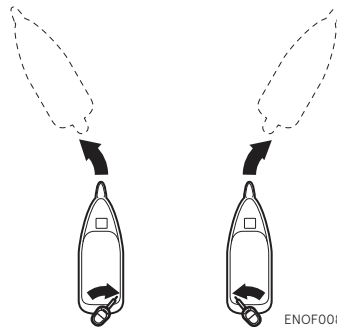

ENOF00892-0

ENOM00050-0

7. Trim angle**WARNING**

- Adjust the trim angle when the engine is stopped.
- Do not put hand or finger in between outboard motor body and clamp bracket

when adjusting trim angle to prevent possible injury.

- Unsuitable trim position can cause loss of control of boat. When testing a trim position, run the boat slowly initially to see if it can be controlled safely.

ENOW00044-1A

WARNING

Excessive trim up or down may cause unstable boat operation, loss of control that may lead to accident during cruising.

- For manual tilt model, if you feel the trim is improperly positioned, stop the boat and readjust trim angle before continuing to cruise.

The trim angle of the outboard motor can be adjusted to suit the transom angle of the hull, and load conditions. Choose an appropriate trim angle that will allow the anti-ventilation plate to run parallel to the water surface during operation.

ENOM00052-0

Proper trim angle

The position of the thrust rod is correct if the hull is horizontal during operation.

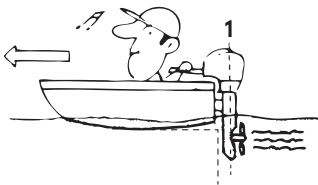

ENOF00051-1

1. Perpendicular to the water surface

ENOM00053-0

Improper trim angle (bow rises too high)

Set the thrust rod lower if the bow of the boat rises above horizontal.



ENOF00052-0

ENOM00054-0

Improper trim angle (bow dips into the water)

Set the thrust rod higher if the bow of the boat is below horizontal.



ENOF00053-0

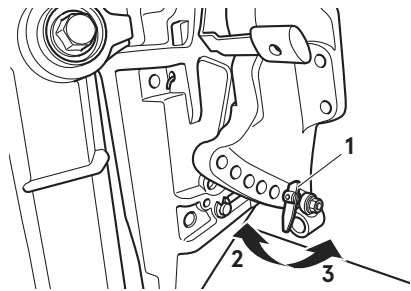

ENOF01724-0

1. Thrust rod
2. Higher
3. Lower

Trim angle adjustment

The transom angle adjustment

1. Stop the engine.
2. Shift into neutral position.
3. Tilt up the outboard motor.
4. Remove the thrust rod as shown picture.

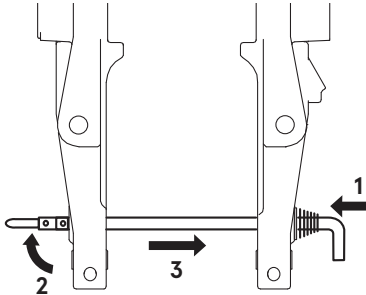

ENOF01238-1

1. Push in
2. Rise the stopper
3. Pull out
5. Reinstall the thrust rod in the desired position securely.
6. Gently tilt down the outboard motor.

ENOM00060-A

8. Tilt up and down

ENOW00055-1

! WARNING

Do not tilt the outboard motor up or down when swimmer(s) and/or passenger(s) are near to prevent them from being caught between outboard motor body and clamp bracket.

ENOW00048-1

! WARNING

When tilting up or down, be careful not to place your hand between the swivel bracket and the stern bracket.

ENOW00056-A

! WARNING

When tilting up outboard motor with fuel joint for over a few minutes, be sure to disconnect fuel hose, or fuel may leak, potentially catching fire.

ENOW00057-1

! CAUTION

Do not tilt up the outboard motor while engine is operating, or no cooling water may be discharged, leading to engine seizure due to overheating.

ENON00921-1

Note

After use, leave the outboard motor upright for a minute to drain the water from inside the engine.

ENOM00062-1B

Tilt up

Push the reverse lock lever down until it stops. (This is the tilt up position.) Then, tilt the outboard motor all the way up until it is locked in place.

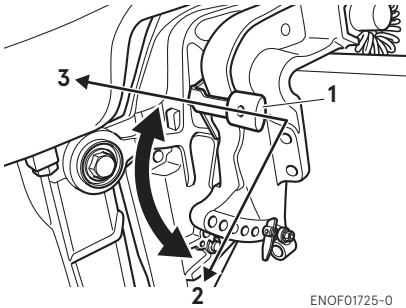

ENOF01725-0

1. Reverse lock lever
2. Tilt up position
3. Tilt down position

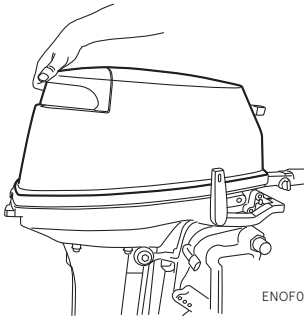

ENOF01726-0

ENOM00063-1
Tilt down

Pull the reverse lock lever upward until it comes to a stop (This is the tilt down position), lift up the outboard motor to free it from the reverse lock, then release to lower the outboard motor.

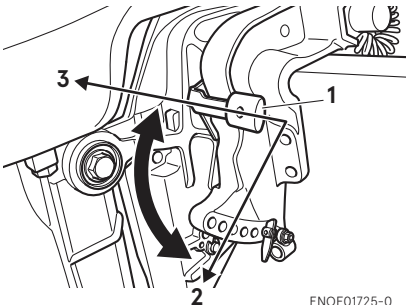

ENOF01725-0

1. Reverse lock lever
2. Tilt up position
3. Tilt down position

ENOW00068-A

9. Shallow water operation

ENOW00051-0

! WARNING

During shallow water operation, be careful not to place your hand between the swirl bracket and the clamp bracket. Be sure to tilt the outboard motor down slowly.

ENOW00053-0

! CAUTION

While in shallow water drive position, do not operate the outboard motor in Reverse. Operate the outboard motor at slow speed and keep the cooling water intake submerged.

ENOW00054-1

! CAUTION

Do not over tilt the outboard motor when driving in shallow water, or air may be sucked through water inlet and sub-water inlet, potentially leading to engine overheating.

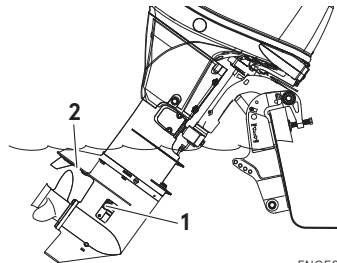

ENOF01144-0

1. Water inlet
2. Sub-water inlet

1. Shallow water running position:
Put the reverse lock lever in the tilt up position, and tilt up the outboard motor to put the outboard motor in the shallow water running position.

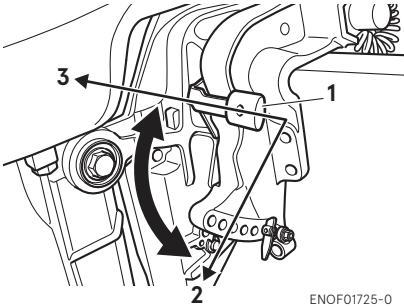

ENOF01725-0

1. Reverse lock lever
 2. Tilt up position
 3. Tilt down position
2. Return to normal running position:
Put the reverse lock lever in the tilt down position, slightly lift up the outboard motor, and then put it down.

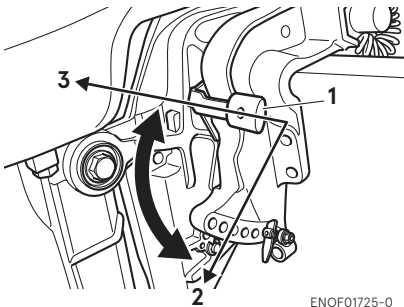

ENOF01725-0

1. Reverse lock lever
2. Tilt up position
3. Tilt down position

REMOVING AND CARRYING THE OUTBOARD MOTOR

ENOM00070-F

1. Removing the outboard motor

ENOW00064-1

CAUTION

Engine may be hot immediately after operation and could cause burns if came in contact. Allow engine to cool down before attempting to carry the outboard.

1. Stop the engine.
2. Disconnect the fuel connector from the outboard motor.
3. Remove the outboard motor from boat and completely drain the water from the gear case.

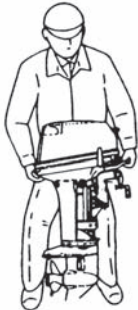

ENOF01705-0

ENOM00071-A

2. Carrying the outboard motor

ENOW00933-0

WARNING

Be sure to disconnect fuel connector except when operating engine.

Fuel leakage is a fire or explosion hazard, which can cause serious injury or death.

ENOW00065-1

WARNING

Close air vent screw on fuel tank before carrying or storing outboard motor and fuel tank, or fuel may leak, potentially catching fire.

ENOW00066-1

CAUTION

- Do not give a shock to an outboard motor during transportation.
- Do not carry or store outboard motor in any of positions described below. Otherwise, engine's exterior may be damaged or water may enter the cylinder through the exhaust port and cause engine problems.

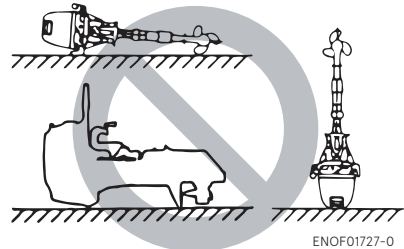

ENOF01727-0

Keep the outboard motor in a vertical position when carrying.

The optional outboard motor stand is recommended for keeping the outboard motor vertical both during transport and storage.

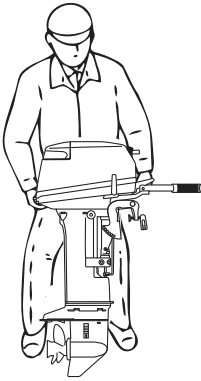

ENON00021-3

Note

If the outboard motor must be laid down, be sure that fuel is completely drained, then lay the outboard motor with port side down on the cushion as shown in the drawing.

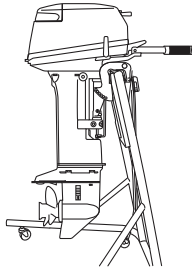

ENOF01738-0

Fuel leakage is a fire or explosion hazard, which can cause serious injury or death.

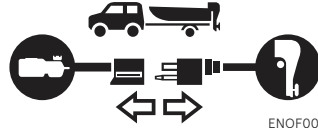

ENOF00075-1

ENOW00068-0

WARNING

Close air vent screw on fuel tank and fuel cock before carrying or storing outboard motor and fuel tank, or fuel may leak, potentially catching fire.

ENOW00071-0

CAUTION

The tilt support device supplied on your outboard motor is not intended for towing. It is intended to support the outboard motor while the boat is docked, beached, etc.

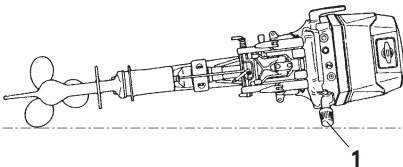

ENOF01728-0

1. Handle

ENOM00072-A

3. Trailing

ENOW00072-0

CAUTION

Trailing in the tilted position may cause damage to the outboard motor, boat, etc.

ENOW00073-A

WARNING

Be sure to disconnect fuel connector except when operating engine.

When transporting a boat on a trailer with the outboard motor attached, disconnect the fuel line from the outboard motor beforehand and keep the outboard motor in the vertical or on a transom saver bar.

Tiller handle type

While transporting outboard motor attached to the boat on a trailer, properly tighten the steering friction bolt to prevent the outboard motor from moving. (page 43).

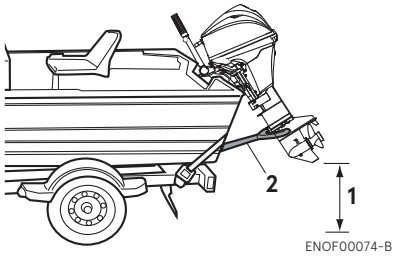

1. Ground clearance should be provided sufficiently.
2. Transom saver bar

ENOW00067-0

⚠ WARNING

Do not go under outboard motor tilted up even if it is supported by support bar, or accidental fall of outboard motor could lead to severe personal injury.

ADJUSTMENT

ENOM00073-C

1. Steering friction

Tiller handle type

ENOW00074-2

WARNING

Steering may be difficult when steering friction adjustment bolt is over tightened, it may also result in loss of control causing an accident and could lead to severe injury.

ENON00506-1

Note

The steering friction adjustment bolt is used to adjust the friction load of the steering. Excessive tightening of the adjustment bolt may cause damage to the swivel bracket.

Steering friction can be adjusted in accordance with your preference by turning the steering friction adjustment bolt.

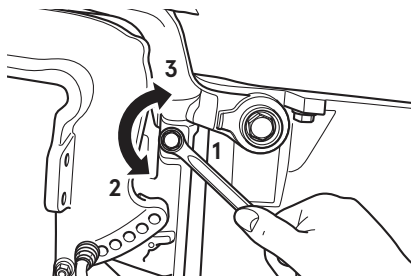

ENOF01729-0

1. Steering friction adjustment bolt
2. Lighter
3. Heavier

ENOM00074-A

2. Throttle grip friction

ENOW00074-1B

WARNING

Do not overtighten the throttle adjustment screw or it could result in difficult handling of the outboard motor, resulting in the loss of control causing an accident and could lead to severe injury.

Friction adjustment of the throttle grip can be made with the throttle adjustment screw.

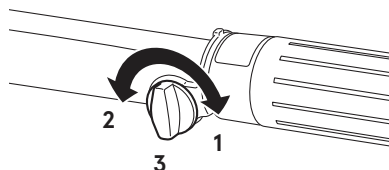

ENOF00445-0

1. Heavier
2. Lighter
3. Throttle friction adjustment screw

INSPECTION AND MAINTENANCE

ENOM00077-1

Care of your outboard motor

To keep your outboard motor in the best operating condition, it is very important that you perform daily and periodic maintenance as suggested in the maintenance schedules as follows.

ENOW00077-1

CAUTION

- **Your personal safety and that of your passengers depends on how well you maintain your outboard motor. Carefully read all of the inspection and maintenance procedures described in this section.**
 - **The maintenance intervals shown in the checklist apply to an outboard motor in normal use. If you use your outboard motor under severe conditions such as frequent full-throttle operation, frequent operation in brackish water, or for commercial use, maintenance should be performed at shorter intervals. If in doubt, consult your dealer for advice.**
 - **We strongly recommend that you use only genuine replacement parts on your outboard motor. Damage to your outboard motor arising from the use of other than genuine parts is not covered under the warranty.**
-

ENOM01005-0

1. Daily Inspection

Perform the following checks before and after use.

ENOW00078-0



WARNING

Do not use outboard motor if any abnormality is found during pre-operation check or it could result in severe damage to the motor or severe personal injury.

Item	Points to Check	Action
Fuel System	<ul style="list-style-type: none"> Check the amount of fuel in the tank. Check for dust or water in the fuel filter. Check rubber pipes for fuel leakage. 	Replenish Clean or replace Replace *1
Electrical Equipment	<ul style="list-style-type: none"> Check that the stop switch functions normally and make sure the lock plate is secured. Check cords for loose connections and damage. Check the spark plugs for dirt, wear and carbon build-up. 	Remedy or replace *1 Correct or replace *1 Clean or replace
Throttle System	<ul style="list-style-type: none"> Check the choke valve to make sure carburetor is functioning normally. Check if the carburetor and magneto are working normally by turning the throttle grip, and check for any looseness between the links. 	Replace *1 Correct *1
Recoil Starter	<ul style="list-style-type: none"> Check ropes for wear and chafing. Check the ratchet for engagement. 	Replace *1 Correct or replace *1
Clutch and Propeller System	<ul style="list-style-type: none"> Check that clutch engages correctly when operating the shift lever and remote control. Visually check propeller for bent or damaged blades. Check the propeller nut is tightened and the split pin is in correct position. 	Adjust *1 Replace.
Installation of Motor	<ul style="list-style-type: none"> Check all the bolts attaching the motor to the boat. Check the thrust rod installation. 	Tighten Tighten
Cooling Water	<ul style="list-style-type: none"> After starting the outboard motor, make sure that water is being discharged from the cooling water check port. 	Repair *1
Tools and Spares	<ul style="list-style-type: none"> Check that there are tools and spare parts for replacing spark plugs, the propeller, etc. Check that you have the spare rope. 	
Other Parts	<ul style="list-style-type: none"> Check if the anode and trim tab are securely installed. Check the anode and trim tab for corrosion and deformation. 	Repair if necessary Replace

*1 Have this handled by your dealer.

ENOM00083-0

Washing outboard motor

ENOW00081-1

WARNING

Do not start engine without removing propeller, turning propeller out in the open may lead to personal injury.

ENOW00082-0

WARNING

Never start or operate the engine indoors or in any space which is not well ventilated. Exhaust gas contains carbon monoxide, a colorless and odorless gas which can be fatal if inhaled for any length of time.

ENOW00920-0

CAUTION

When washing the outboard motor, be careful not to spray the water inside of the top cowl, especially electrical components.

ENON00026-0

Note

It is recommended to check chemical properties of water on which your outboard motor is regularly used.

10

If outboard motor is used in salt water, brackish water or water with high acidic level, use fresh water to remove salt, chemicals or mud from exterior and cooling water passage after every use or before storing outboard motor for long time. Before flushing, remove the propeller and the forward thrust holder.

ENOM00085-C

Flushing attachment

1. Tilt down the outboard motor.
2. Remove the water plug from the gear case, and screw in the flushing attachment.
3. Connect a water hose. Turn on the water and adjust the flow (Be sure to seal the water inlet and sub-water inlet, located in the gear case with tape).
4. Put the shift lever in the neutral position and start the engine. Continue flushing the outboard motor for 3 to 5 minutes at idling.
5. Stop the engine and water supply. Remove the flushing attachment and tape. After the flushing, be sure to reattach the water plug.

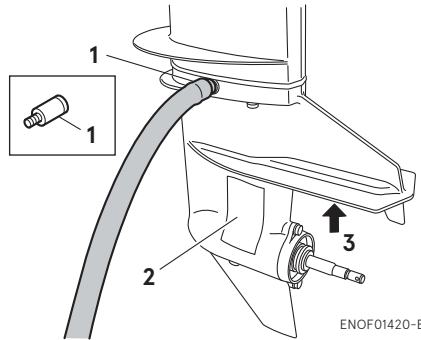

ENOF01420-B

1. Flushing attachment (option)
2. Water inlet
3. Sub-water inlet

ENOM00085-A

Flushing by test tank

ENOW00036-1A

⚠ CAUTION

When starting the outboard motor in the test tank, make sure that:

1. Water level is at least 10 cm (4 in.) above the anti-ventilation plate to avoid overheating of the engine.
2. Run at idling only
3. Remove the propeller
(See page 53)

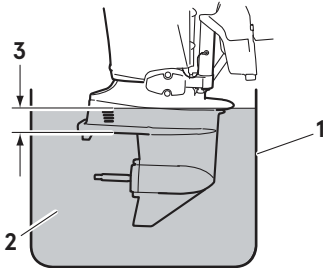

ENOF00863-0

1. Test tank
2. Water
3. Over 10 cm (4 in.)

ENOM01903-0

Gear case flushing device

ENOW00082-0

⚠ WARNING

Never start or operate the engine indoors or in any space which is not well ventilated. Exhaust gas contains carbon monoxide, a colorless and odorless gas which can be fatal if inhaled for any length of time.

ENOW00986-0

⚠ CAUTION

Never leave the outboard motor unattended while running on the flushing devise. When the flushing devise slip off from the gear

case, the engine will overheat and may cause serious damage.

1. Fully tilt down the outboard motor.
2. With the propeller removed, seal the sub-water inlet with a tape to prevent air from being sucked into the water pump.

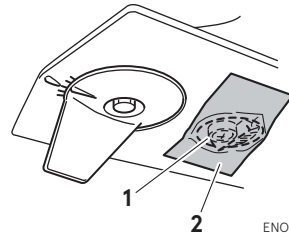

ENOF02559-0

1. Sub-water inlet
2. Tape
3. Install the gear case flushing device on gear case so that the rubber cups cover the cooling water inlets tightly.
4. Connect a water hose to the flushing device and turn on the water and adjust the flow so that excess water continues leaking out from around the rubber cups to ensure the engine is receiving an adequate supply of cooling water.

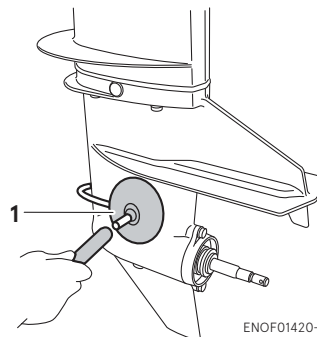

ENOF01420-C

1. Gear case flushing device

5. Place the shift lever in the neutral position and start the engine and run at idle speed for 3-5 minutes.
6. Check if a steady stream of water flows from the cooling water check port.
7. Stop the engine and turn off the water. Remove the flushing devise and tape. Install the propeller.
8. Leave the outboard motor in vertical position to completely drain the cooling water from the outboard motor.

ENOM01106-1

2. Periodic Inspection

It is important to inspect and maintain your outboard motor regularly. Make sure to perform each service at interval specified in the chart below. Maintenance intervals are determined by the number of hours outboard motor has been used or number of months, whichever comes first.

Recode inspection performed in the INSPECTION & MAINTENANCE LOG at the back of this manual.

Item		Servicing Interval			Action	Remarks
		10 hours or 1 month	50 hours or 3 months	Every 100 hours or 6 months		
Fuel System	Carburetor *1			●	Strip, clean and adjust. Adjust idling.	
	Fuel filter	●	●	●	Check and clean or Replace.	
	Piping/Hose	●	●	●	Check and Replace.	
	Fuel tank	●		●	Clean.	
Ignition	Spark plugs	●		●	Check gaps. Remove carbon deposits or Replace.	
	Ignition timing *1	●		●	Adjust timing.	
Starting System	Starter motor *1			●	Check for salt deposits and battery cable condition.	
	Battery	●	●	●	Check installation, fluid quantity, gravity.	
	Starter rope	●	●	●	Check for wear or damage.	
Lower Unit	Propeller	●	●	●	Check for bend blades, damage, wear.	
	Gear oil	●	●	●	Change or replenish-oil and check for water leaks.	
	Water pump *1		●	●	Check for wear or damage.	Replace impeller every 12 months.
Bolt and Nuts		●	●	●	Retighten.	
Sliding and Rotating Parts. Grease Nipples			●	●	Apply and pump in grease.	

*1: Have this handled by your dealer.

Outboards used in rental, commercial, or other under severe condition as described below in detail require more frequent inspections and maintenance than shown in this manual.

- Continuous operation at maximum engine speed
- Continuous operation at idling or trolling speed
- Operation without appropriate warm up
- Stopping without sufficient time for the engine to cool down
- Frequent sudden acceleration and sudden deceleration
- Frequent stop start operation
- Frequent shifting operation
- Frequent operation in acidic, polluted, muddy, sandy, or shallow water

Appropriate maintenance can prolong your engine life.

Consult your Tohatsu authorized dealer for suitable maintenance interval depending on operating and environmental conditions.

ENOM00093-C

Fuel filters and fuel tank cleaning

ENOW00093-1

⚠ WARNING

Gasoline and its vapor is very flammable and can be explosive.

- Do not start this procedure while engine is operating or while engine is hot.
- Place fuel filter away from every source of ignition such as sparks or open flames.
- If gasoline is spilled, wipe up immediately and dispose according to the local regulations.
- Install fuel filter with all related parts in place, or fuel leak could occur, leading to catching fire or explosion.
- Check fuel system regularly for leakage.
- Contact authorized dealer for fuel system services. Services by unqualified person could lead to engine damage.

Water or dirt in the fuel filter and tank will cause engine performance problems. Check and clean the fuel filter and tank at specified intervals or after the out-board motor has been stored over three months.

Fuel filters are provided inside the fuel tank and engine.

ENOM00094-0

Fuel filter (for engine)

1. Check the cup for water and debris.

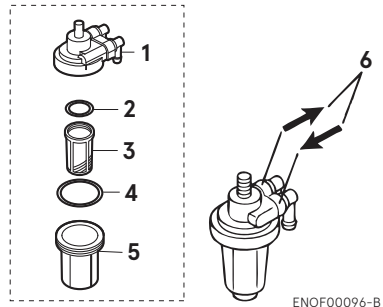
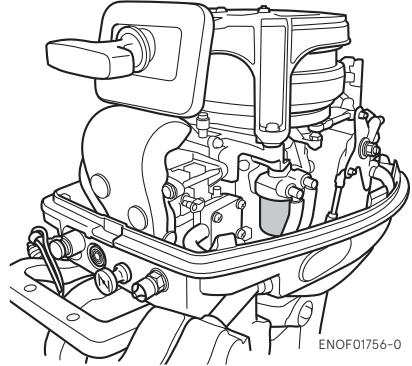

1. Body
2. O-ring
3. Filter
4. O-ring
5. Cup
6. Arrow to indicate fuel flow direction

2. If present, disconnect hoses from the fuel connector (male) and the fuel pump.
3. Remove the cup, filter and O-rings from the fuel filter body.
4. Check the wear and clogging for each part, and replace if necessary.

5. Remove fuel and any water or debris from the cup, filter and hoses.
6. Reassemble all parts.

ENOM00096-A

Fuel filter (for fuel tank)

1. Remove four screws to detach the Fuel Pick-Up.
2. Clean the fuel filter and replace the gasket.
3. Reassemble all parts.

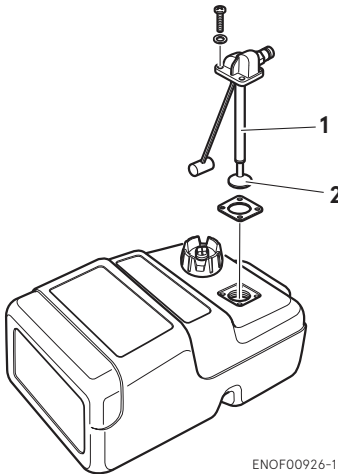

1. Fuel pick-up
2. Filter

ENOM00098-A

Gear oil replacement

ENOW00076-1

⚠ WARNING

- Be sure that the outboard motor is secured to transom or service stand, or accidental drop or fall of outboard motor could lead to severe personal injury.
- Be sure to lock the outboard motor in the tilt up position, or accidental fall of out-

board motor could lead to severe personal injury.

- **Do not go under outboard motor in the tilt up position and locked, or accidental fall of outboard motor could lead to severe personal injury.**

ENON00934-1

Note

Please dispose of used oil in a manner that is compatible with the environment.

We suggest you take it in a sealed container to your local service station for rec-lamation. Do not throw it in the trash, pour it on the ground or down a drain.

1. Tilt down the outboard motor.
2. Remove the oil plugs (lower and upper), and completely drain the gear oil into a pan.

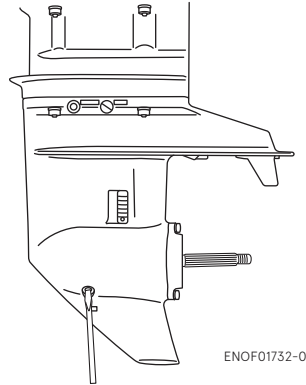

3. Insert the oil tube nozzle into the lower oil plug hole and fill with gear oil by squeezing the oil tube until oil flows out of the upper plug hole. Make sure that no bubbles are coming out of the upper plug hole and there is no air inside the gear case.

ENON00033-0

Note

Use genuine gear oil or the recommended one (API GL-5; SAE #80 to #90).
Required volume: approx. 360 mL (11.8 fl.oz.).

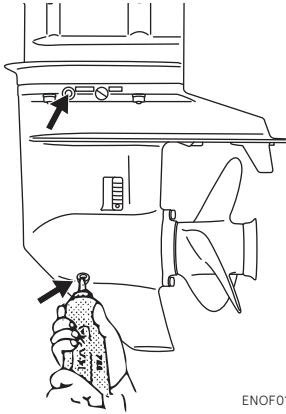

ENOF01733-0

4. Install the upper oil plug, and then remove oil tube nozzle and install the lower oil plug.

Oil plug specified tightening torque
4N·m (3 ft·lb, 0.4 kgf·m)

ENOW00095-0

⚠ CAUTION

Do not reuse oil plug gasket. Always use new gasket and tighten oil plug properly to prevent entry of water into lower unit.

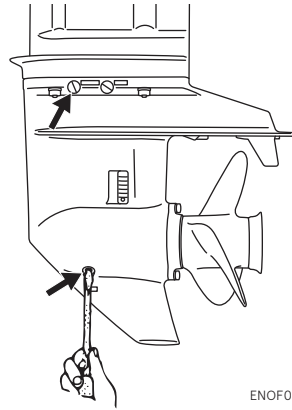

ENOF01734-0

ENOW00928-1

⚠ CAUTION

If gear oil is spilled, wipe off immediately and dispose according to the local regulations.

ENON00032-1

Note

If the gear oil color appears to be milky color, contact your dealer.

ENOM00086-A

Propeller replacement

ENOW00084-1

⚠ WARNING

- Do not install or remove propeller on the outboard motor with spark plug caps attached, shift in forward or reverse, main switch at other than "OFF", engine stop switch lock attached to the switch, and starter key attached, or engine could accidentally start leading to serious personal injury. Disconnecting battery cable is recommended (if equipped).
- The propeller edge is thin and sharp. Wear the gloves while installing or removing to protect your hands.

ENOW00086-1

CAUTION

- Do not install propeller without thrust holder, or propeller boss could be damaged.
- Do not reuse split pin.
- After installing split pin, spread bend both end of the pin apart to lock propeller in place.

A worn-out or bent propeller will lower the outboard motor's performance, and cause engine trouble.

1. Put a piece of wood block between propeller blade and anti-ventilation plate to hold propeller.

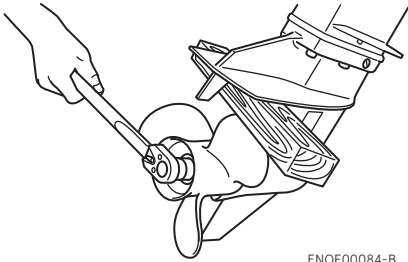

ENOF00084-B

2. Remove the split pin, propeller nut and washer.
3. Remove the propeller and thrust holder.
4. Apply waterproof grease to the propeller shaft before installing a new propeller.
5. Install the thrust holder, propeller, stopper, washer and propeller nut onto the shaft.

10

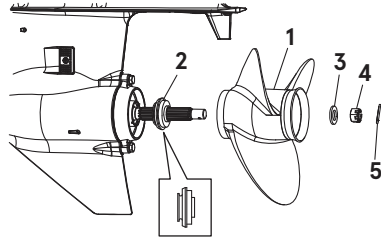

ENOF00084-C

1. Propeller
2. Thrust holder
3. Washer
4. Propeller nut
5. Split pin
6. Tighten the propeller nut to specified torque and align one of grooves to propeller shaft hole.

Propeller nut torque:

25 N·m (18 ft·lb, 2.5kgf·m)

7. Install a new split pin into the nut hole and bend both ends of pin apart to lock propeller in place.

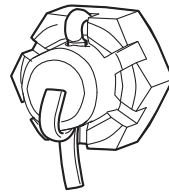

ENOF00084-E

ENOM00087-B

Spark plugs replacement

ENOW00087-1

WARNING

- Do not reuse spark plug, if the insulation is damaged or sparks can leak through crack, potentially leading to electric shock, explosion and/or fire.

- Do not touch spark plugs immediately after stopping engine as they will be hot and could cause severe burns if touched.

ENOW00929-0

CAUTION

Use only the recommended spark plugs. Spark plugs which have an different heat range may cause engine damage.

If the spark plug(s) is fouled, has carbon build up, or is worn, it should be replaced.

When reusing spark plugs, remove dirt from the electrodes and adjust spark gap to specification.

1. Stop the engine.
2. Remove the top cowl.
3. Remove the spark plug caps.
4. Remove the spark plugs by turning it counter-clockwise, using a 21 mm (13/16 in) socket wrench and handle that is provided in tool bag.
5. Inspect the spark plug. Replace the spark plug with wear on electrodes and if the insulators are cracked or chipped.
6. Measure the spark gap with a wire type feeler gauge. The gap should be 0.9-1.0 mm (0.035-0.039 inches). If the gap is different, replace the spark plug with a new one
Use spark plug NGK BP7HS-10

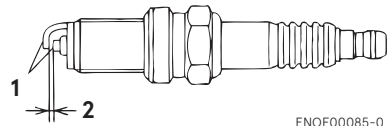

ENOF00085-0

1. Electrode
 2. Spark gap (0.9-1.0 mm, 0.035-0.039 in)
7. Install the spark plug by hand and turn it carefully to avoid cross-threading.
 8. Tighten the spark plug to the specified torque.

ENON00028-2

Note

- **Spark plug tightening torque:**
27 N·m (20 ft·lb) [2.7 kgf·m]

If a torque-wrench is not available when you are installing a new spark plug, tighten it 1/2 to 2/3 a turn past finger-tight. If reusing a spark plug, tighten 1/12 a turn past finger tight. Have the spark plug adjustment to the correct torque as soon as possible with a torque-wrench.

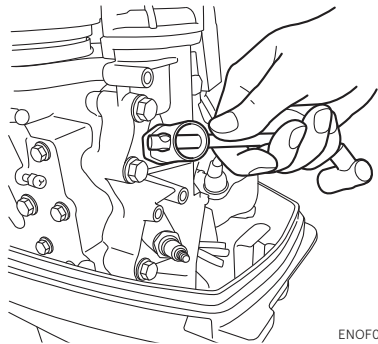

ENOF0173

ENOM00088-1A

Anode replacement

A sacrificial anode protects the outboard motor from galvanic corrosion. Anode is located on the gear case, cylinder etc.. When the anode is eroded more than 1/3 of original size, replace it.

ENON00029-1

Notes

- Never grease or paint the anode.
- At each inspection, re-tighten all the anode attaching bolts. Those bolts may loosen if the anodes are corroded.

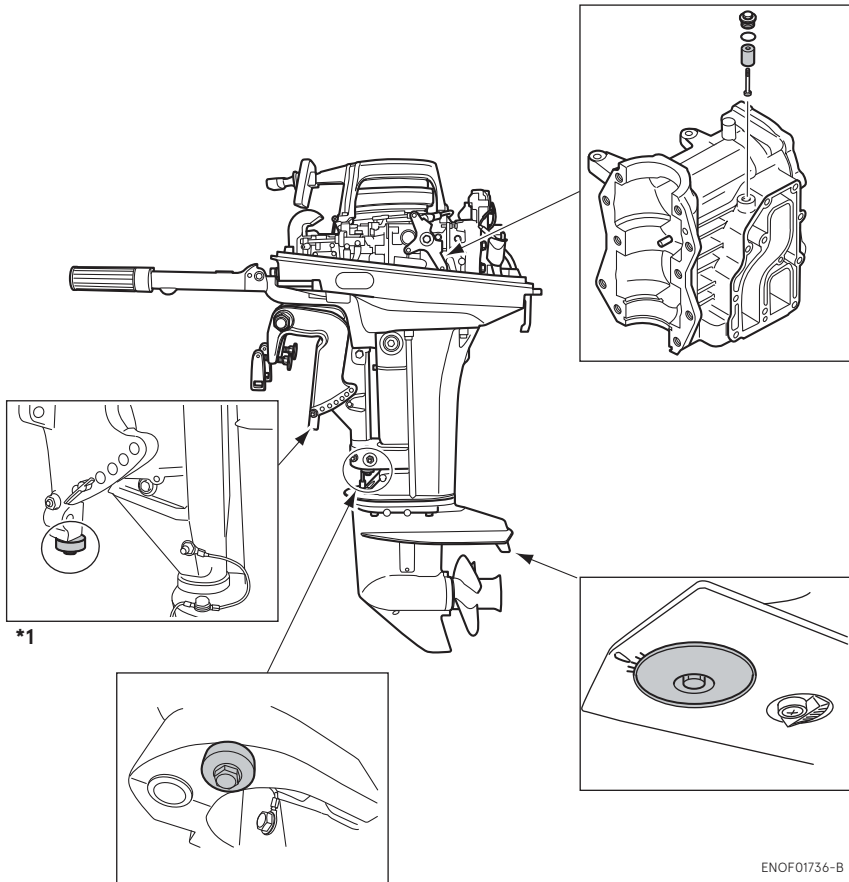

ENOF01736-B

*1 : Both side

ENOM00960-0

Grease point

Apply waterproof grease to the parts shown below.

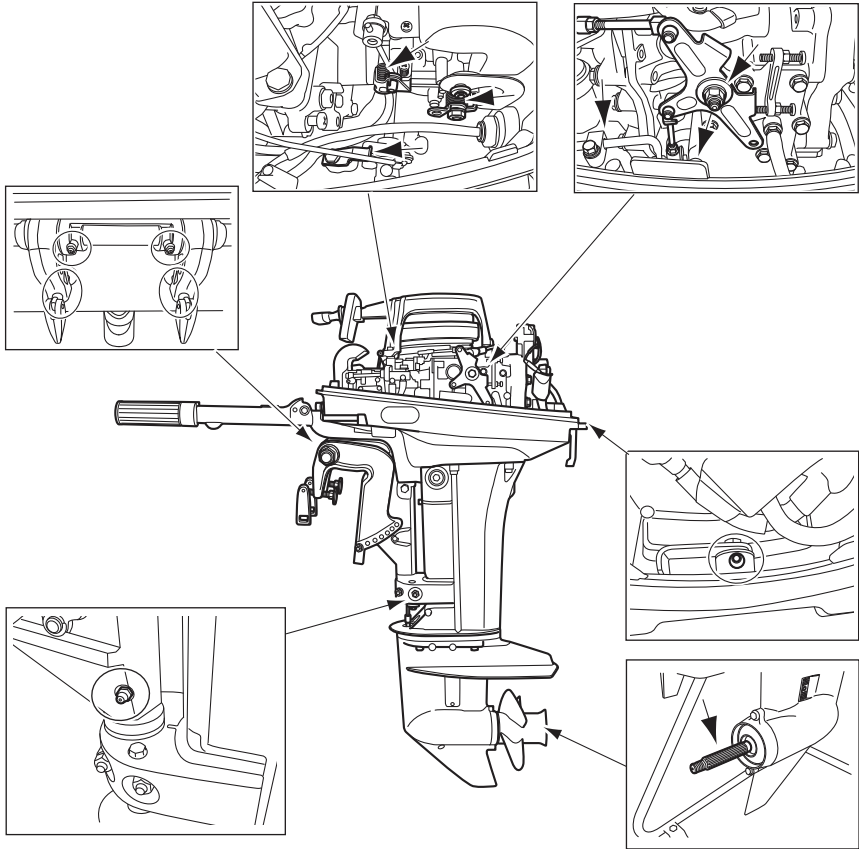

ENOF01737-A

ENOM00100-A

3. Off-season storage

ENOW00934-0

WARNING

- Be sure to disconnect fuel connector except when operating engine.
- Fuel leakage is a fire or explosion hazard, which can cause serious injury or death.

ENOW00097-0

WARNING

Be sure to use cloth to remove fuel remaining in the cowl and dispose of it in accordance with local fire prevention and environment protection regulations.

ENOW00096-0

CAUTION

Before servicing the motor for storage:

- Remove the battery cables.
- Remove the spark plug caps from the spark plugs.
- Do not run the motor out of the water.

Before you put your outboard motor in storage, it is a good opportunity to have it serviced by your dealer.

Be sure to use fuel stabilizer while running the motor before storage. (See page 59)

ENOM00101-C

Engine

1. Wash the engine exterior and flush the cooling water system thoroughly with fresh water. Drain the water completely.
Wipe off any surface water with an oily rag.

2. Remove the fuel hose from the outboard motor.
3. Drain all fuel from the fuel hoses, fuel pump, fuel filter (See page 51) and carburetor (See page 60), and clean these parts.
Keep in mind that if residue in the carburetor for a long time, gum and varnish will develop, causing the float valve to stick, restricting the fuel flow.
4. Remove the spark plugs and put a teaspoon of engine oil or spray storage oil into the combustion chamber through the spark plug holes.
5. Pull the recoil starter several times to lubricate inside the cylinder.

ENOW00930-1

WARNING

- Be sure to remove stop switch lock to prevent the spark plugs from igniting.
 - Put a cloth to spark plug hole and wipe up any spilled engine oil, when cranking the outboard motor.
6. Change the gear oil in the gear case (See page 52).
 7. Apply grease to grease point (See page 57).
 8. Stand the outboard motor up vertically in a dry area.

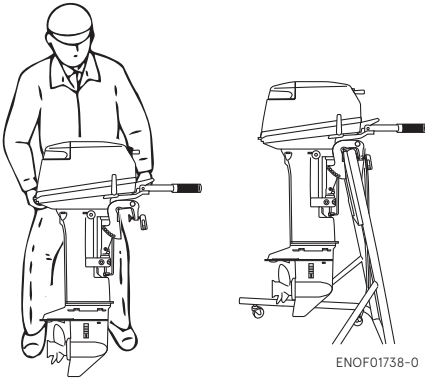

⚠ CAUTION

- Do not give a shock to an outboard motor during transportation.
 - Do not carry or store outboard motor in any of positions described below.
- Otherwise, engine's exterior may be damaged or water may enter the cylinder through the exhaust port and cause engine problems.

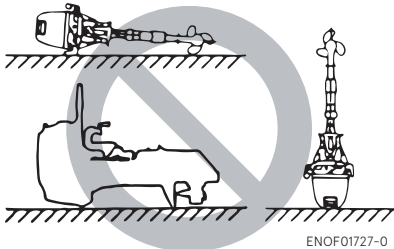

ENON00021-3 Note

If the outboard motor must be laid down, be sure that fuel is completely drained, then lay the outboard motor with port side down on the cushion as shown in the drawing.

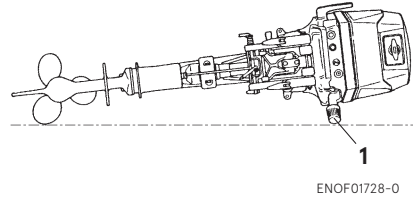

1. Handle

ENOM00950-1 Adding a fuel stabilizer

When adding a fuel stabilizer additive (commercially available), first fill the fuel tank with fresh oil and fuel. If the fuel tank is only partially filled, air in the tank may deteriorate the fuel during storage.

1. Before adding fuel stabilizer additive, drain the carburetor (See page 60).
2. Follow the instructions on the label when adding the fuel stabilizer additive.
3. After adding the additive, let the outboard motor run in water for 10 minutes to make sure any old fuel in the fuel system has been completely replaced by the fuel with additive.
4. Turn the engine OFF

ENON00891-1 Note

If your motor is used occasionally, it is recommended to use a high quality fuel stabilizer for the fuel and keep the fuel tank full to reduce condensation and evaporation.

ENOM00970-A

Fuel system draining

ENOW00028-A

WARNING

For details on handling fuel, contact an authorized dealer.

Fuel and fuel vapors are extremely flammable and can be explosive.

- If fuel is spilled, wipe it up immediately.
- Keep the fuel tank well away from sources of ignition, e.g. sparks or open flames
- Perform all work outdoors or in a well ventilated place.

ENOW00097-0

WARNING

Be sure to use cloth to remove fuel remaining in the cowl and dispose of it in accordance with local fire prevention and environment protection regulations.

1. Disconnect the fuel hose from the outboard motor.
2. Remove the top cowl.
3. Place an appropriate rag under the drain screw.
4. Loosen the carburetor drain screw.
5. Leave the outboard motor until all fuel has been drained.
6. When thoroughly drained, retighten the drain screw securely.
7. Check the drained fuel for the presence of contaminants. If the fuel is contaminated, check the fuel filter and fuel in the fuel tank.

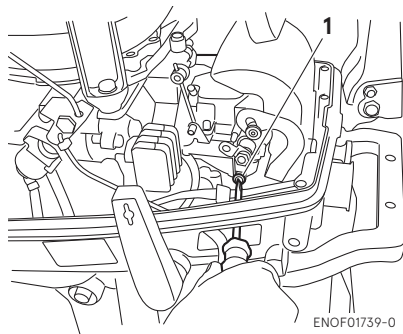

ENOF01739-0

1. Carburetor drain screw

ENOM00104-H

4. Pre-season check

The following steps must be taken when first using the engine after off season storage.

1. Check that the shift and throttle function properly. (Be sure to turn the propeller shaft when checking the shift function for any damage on the shift linkage.)
2. Fill the fuel tank with oil and fuel.
3. Connect the fuel line to the engine, and squeeze primer bulb.
4. Before starting the engine, disconnect stop switch lock and pull recoil starter approximately 10 times in order to circulate the oil.
5. Start the engine and warm up the engine for 3 minutes in the "NEUTRAL" position.
6. Run the engine for 5 minutes at the slowest speed.
7. Run the engine for 10 minutes at half throttle. The oil shall circulate to assure optimum performance.

ENOM00105-D

5. Submerged outboard motor

ENOW00098-0

CAUTION

Do not attempt to start submerged outboard motor immediately after it is recovered, or engine could be severely damaged.

After taking your outboard motor out of the water, immediately take it to your dealer.

The following are the emergency measures to be taken for a submerged outboard motor.

1. Wash the outboard motor with fresh water to remove salt or dirt.
2. Remove the spark plugs, and completely drain the water from the engine by pulling recoil starter several times.
3. Inject a sufficient amount of engine oil through the spark plug holes. Pull the recoil starter rope several times to circulate the oil throughout the outboard motor.

ENOM00106-1

6. Cold weather precautions

If you moor your boat in cold weather at temperatures below 0°C (32°F), water residue in water pump may freeze and may damage the pump, impeller, etc. To avoid, submerge the lower half of the outboard motor into the water.

ENOM00107-A

7. Striking underwater object

ENOW00935-0

CAUTION

Striking the sea bottom or an underwater object may severely damage the outboard motor.

Follow the procedure below and consult a dealer as soon as possible.

1. Stop the engine immediately.
2. Check the control system, gear case, boat transom etc.
3. Return to the nearest harbor slowly and carefully.
4. Consult a dealer check the outboard motor before operation again.

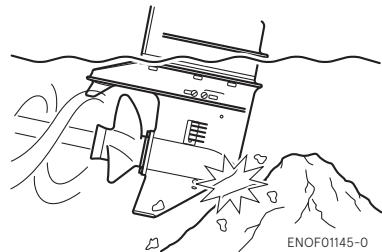

ENOF01145-0

ENOM00120-0

8. Auxiliary outboard motor operation

When the auxiliary outboard motor will not be used, be sure to remove the stop switch lock, shift into forward, and then tilt the outboard motor up. Otherwise, overrotation of the propeller due to water spray and water ingestion that could cause damage to the outboard motor.

TROUBLESHOOTING

ENOM00109-0

If you encounter a problem, check the list below to determine the cause and to take the proper action.

An authorized dealer will always be happy to provide any assistance and information.

Difficult to start engine	Engine starts but stops immediately	Poor idling	Unstable engine running speed or engine stops	Abnormally high engine speed	Abnormally low engine speeds	Unable to reach high speed	Over-heating of engine	
●	●		●					Empty fuel tank
●	●	●	●		●	●	●	Incorrect connection of fuel system
●	●	●	●		●	●	●	Air enters fuel line
●	●	●	●		●	●	●	Deformed or damaged fuel pipe
●	●	●	●		●	●	●	Closed air vent on fuel tank cap
●	●	●	●		●	●	●	Clogged fuel filter, fuel pump or carburetor
		●	●		●	●	●	Use of improper engine oil
●	●	●	●			●	●	Use of improper gasoline
●	●							Excessive supply of gasoline
●	●	●	●		●	●	●	Poor carburetor adjustment
●	●	●	●			●	●	Recirculation pipe broken
●	●	●	●		●	●	●	Use of non-specified spark plugs
●	●	●	●		●	●		Dirt or carbon deposits on spark plugs

Difficult to start engine	Engine starts but stops immediately	Poor idling	Unstable engine running speed or engine stops	Abnormally high engine speed	Abnormally low engine speeds	Unable to reach high speed	Over-heating of engine	
●	●	●	●		●	●		No sparks or weak sparks
			●		●	●	●	Insufficient cooling water flow
		●	●			●	●	Faulty thermostat
				●		●	●	Propeller cavitation
				●	●	●	●	Incorrect propeller selection
		●		●	●	●	●	Damaged or bent propeller
				●	●	●	●	Unbalanced load in boat
				●		●	●	Transom too high
					●	●	●	Transom too low
●	●	●			●	●	●	Incorrect adjustment of throttle link
●	●	●			●	●	●	Incorrect adjustment of ignition timing
●								Insufficient battery capacity, loose terminals, corrosion
●								Safety switch lock plate not fitted

TOOL KIT AND SPARE PARTS

ENOM01008-0

The followings are a list of the tools and spare parts provided with the motor.

	Name	Quantity	Remark
Servicing Tools	Tool Bag	1	
	Socket Wrench	1	21 mm
	Socket Wrench	1	10 x 13 mm
	Socket Wrench Handle	1	
	Pliers	1	
	Screwdriver (Phillips-type and flat head)	1	Adapter-type
Spare Parts	Anode (for Bracket)	2	
	Anode (for Gear Case)	1	
	Anode (for Cylinder block)	1	
	O ring (for Cylinder block anode)	1	
	Water Pump Impeller	1	
	Gasket (for Gear Oil Plug)	2	
	Grease	1	
	Starter Rope	1	
	Spark Plug	2	NGK BP7HS-10
	Collar	2	for Tiller handle
Split Pin	1		
Parts Packaged with Engine	Fuel Tank (with primer bulb)	1	
	Grease Up Point Chart	1	
	Owner's Manual	1	

■ PROPELLER TABLE

ENOM01108-1

To ensure optimum performance, the propeller should match the boat type and its load.

Use a genuine propeller.

When selecting propeller, make sure that RPM stays in the maximum operating range of engine at wide open throttle.

MX15E2: 4,500 to 5,500 min^{-1} (rpm).

MX18E2: 5,200 to 5,800 min^{-1} (rpm).

	Mark	Propeller Size (Diameter x pitch)	
		inch	mm
Heavier Load Lighter Load	6	9.2 x 6.1	234 x 155
	8	9.25 x 8	235 x 203
	9	9.25 x 9	235 x 229
	10	9.25 x 10	235 x 254
	11.5	9.25 x 11.5	235 x 292

OWNER'S MANUAL

MX 15E₂
MX 18E₂

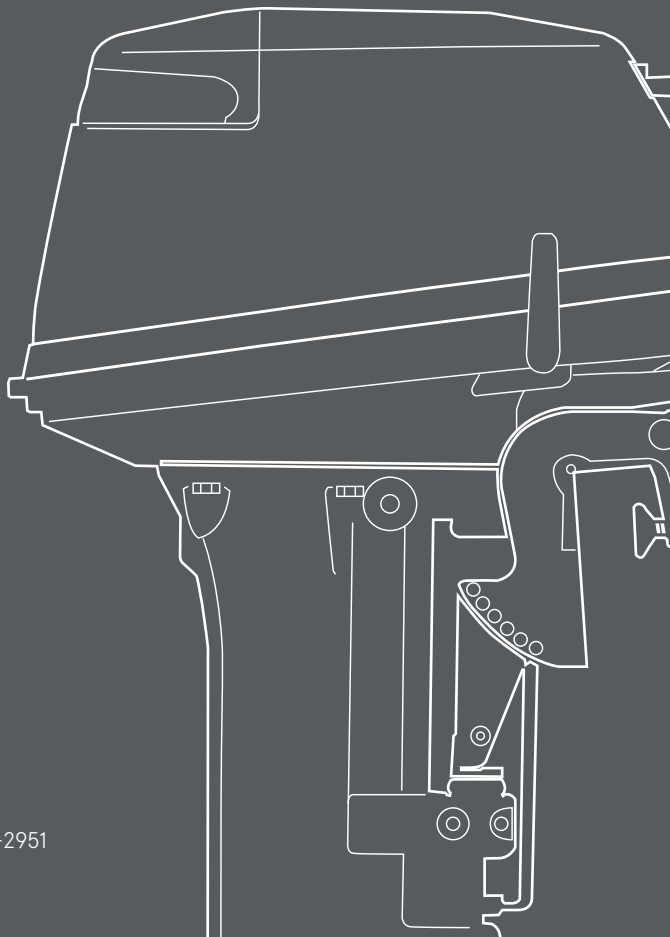

TOHATSU CORPORATION

5-4, Azusawa 3-Chome, Itabashi-Ku
Tokyo 174-0051, Japan
Tel: +81-3-3966-3117 Fax: +81-3-3966-2951
www.tohatsu.com