



TOHATSU *OUTBOARDS*

9.9 **15** **18**
C C D

OWNER'S HAND BOOK

2003.1.1

Copyright © 2007 Tohatsu Corporation. All rights reserved. No part of this manual may be reproduced or transmitted in any form or by any means without the express written permission of Tohatsu Corporation.

The warranty will cover only your TOHATSU product and will not cover the boat mounted with the product, trailer, equipment or accessories associated to the product.

Serial Number

Please record the serial number of the engine (indicated on the lower engine cover and cylinder block) in the space below. This number will come in handy in the event of theft or to help in quickly identifying the product type.

Serial Number: _____

*The dealer mentioned in this manual means TOHATSU authorized dealer.

To You the Customer:

Thank you for selecting a Tohatsu product. You are now the proud owner of an excellent outboard engine, which will serve you for many years to come.

We would like to point out that carefree usage can only be assured on the condition that this manual is read through in its entirety and maintenance routines, as described later in this manual, are followed carefully. Should difficulty arise with the engine, please check the trouble according to the troubleshooting list at the end of this manual, and if it cannot be remedied, contact an authorized Tohatsu service shop or your dealer.

We hope you will get much enjoyment from this product and wish you good luck with your boating adventures.

Tohatsu Corporation

TOHATSU ENGINE

OWNER REGISTRATION AND IDENTIFICATION

Upon purchasing this product, be sure your dealer fills out the WARRANTY CARD correctly and mails it to the distributor, completely filled in. This card identifies you as the legal owner of the product and serves as your warranty registration of the same.

If this procedure is not followed, your outboard will not be covered by warranty.

PREDELIVERY CHECK

Be sure that the product has been checked by an authorized TOHATSU dealer before the delivery.

Warranty

This TOHATSU product is fully guaranteed against defective materials and workmanship for the period from the date of purchase, provided that the purchase has been registered in accordance with the above.

The warranty will not apply to normal worn parts, adjustments, tune-ups or to any damage caused by;

- 1) Uses or operations NOT conforming to the instructions described in this owners manual;
- 2) Participating in or preparing for racing or other competitive activity;
- 3) Water entering the engine or the engine room;
- 4) Any other thoughtless use or operation.

The warranty will become void if the product has been altered, modified or repaired by any other than a company or a service firm authorized by TOHATSU.

NOTICE

HEED ALL WARNINGS AND CAUTIONS AS SET FORTH HEREIN. THEY HAVE BEEN INCLUDED FOR YOUR SAFETY AND MUST BE READ CAREFULLY. NEGLIGENCE IN OBSERVING SUCH WARNINGS AND CAUTIONS COULD RESULT IN SEVERE INJURY OR DEATH.

EMERGENCY STOP SWITCH

The stop switch will cut off the engine when the stop switch line is pulled out. This line connects to the wrist of the operator, effectively preventing injuries from the propeller in case he fallen overboard.

We highly recommend use of the stop switch line, since it can save the life of the operator if bad things come to worse. However, we would also like to point out the drawbacks of the switch to the operator. Accidental activation of the switch (such as the line being pulled in heavy seas), could cause passengers to lose their balance, fall overboard, and could result in loss of power in heavy seas, strong currents or high winds. Loss of control while mooring is another potential hazard.

To prevent such hazardous situations, the line is curled and will extend to a full 1,300 mm.

WARNING

As the operator/driver of the boat, you are responsible for the safety of those aboard, other crafts around you and that local boating regulations are followed. As such you should possess thorough knowledge of correct operation of the boat, its accessories and the engine. Thus, to learn about correct operation and maintenance of the engine, please read through this manual carefully.

WARNING

It is very difficult for a person standing or floating in the water to take evasive action should he see a power boat heading in his direction, even at a slow speed. Therefore, it is strongly recommended that when your boat is in the immediate vicinity of people in the water, the engine be shifted to neutral and shut off.

SERIOUS INJURY IS LIKELY IF CONTACT IS MADE WITH A PERSON IN THE WATER BY A MOVING BOAT, GEAR HOUSING, PROPELLER, OR ANY SOLID DEVICE RIGIDLY ATTACHED TO A BOAT OR GEAR HOUSING.

It is the operator's responsibility to perform all safety checks and to ensure that all lubrication and maintenance instructions are complied with for safe operation. It is also the operator's responsibility to return the unit to the local dealer for periodic inspection.

Correct periodic maintenance and good care of this outboard engine will lessen the chance for problems and keep overall operating expenses at a minimum.

SERVICING, REPLACEMENT PARTS & LUBRICANTS

Only let an authorized TOHATSU service shop perform servicing or maintenance on this product. Be sure to use genuine parts, and genuine lubricants or recommended lubricants.

MAINTENANCE

As the owner of this outboard engine, you should have acquainted yourself with the correct maintenance of the same. Please comply with all instructions on lubrication and maintenance, and return it to the dealer or service shop for periodic inspection at the prescribed intervals.

Troublefree operation cannot be expected unless the engine receive correct periodic maintenance and is taken good care of. Moreover, if such maintenance is performed periodically, it is not likely that a costly overhaul would ever be required.

USE OF SERVICE SHOP

When subjecting your TOHATSU product to a check or a repair, please be sure to use a TOHATSU dealer authorized by the TOHATSU or a TOHATSU agent.

CONTENTS

	Page
TOHATSU ENGINE	
1. SPECIFICATIONS	2
2. NOMENCLATURE	3
3. INSTALLATION	
1. MOUNTING THE ENGINE ON BOAT	6
2. INSTALLING THE REMOTE CONTROL DEVICES	8
3. MOUNTING THE BATTERY	13
4. PREPARATION BEFORE OPERATION	14
1. FUEL OIL	14
2. BREAK-IN RUNNING	16
5. RUNNING	17
1. TO START	17
2. WARMING UP ENGINE	22
3. FORWARD AND REVERSE	23
4. STOPPING	25
5. TILT-UP, TILT DOWN	26
6. SHALLOW WATER RUNNING	27
6. REMOVING THE MOTOR	28
7. STEERING FORCE ADJUSTMENT	29
8. INSPECTION AND MAINTENANCE	
1. DAILY INSPECTION	30
2. PERIODIC INSPECTION	34
3. WINTER STORAGE	37
4. PRE SEASON CHECK	39
5. SUBMERGED MOTOR IN WATER	40
6. PRECAUTIONS IN COLD WEATHER	40
7. CHECKING AFTER STRIKING UNDER WATER OBJECT	40
9. TROUBLE SHOOTING	41
10. ASSOCIATED PARTS	43
11. ACCESSORIES	44
12. PROPELLER TABLE	45
13. WIRING DIAGRAMS	46

1. SPECIFICATIONS

MODEL	M9.9C	M9.9C EF(*)	M9.9C EP(*)	M15C	M15C EF(*)	M15C EP(*)	M18D	M18D EF(*)	M18D EP(*)
Overall Length, mm (in)	869 (34.2)		585 (23.2)	869 (34.2)		585 (23.2)	869 (34.2)		585 (23.2)
Overall Width, mm (in)	345 (13.6)		288 (11.3)	345 (13.6)		288 (11.3)	345 (13.6)		288 (11.3)
Overall Height, mm (in)	S: 1052 (41.4)			L: 1179 (46.4)	LL: 1255 (49.4)		UL: 1306 (51.4)		
Transom Height, mm (in)	S: 435 (17.1)			L: 562 (22.1)	LL: 638 (25.1)		UL: 689 (27.1)		
Weight (S), kg (lb)	37 (81.6)	39 (86)	38.5 (84.9)	37 (81.6)	39 (86)	38.5 (84.9)	37 (81.6)	39 (86)	38.5 (84.9)
Output, KW (PS)	7.4 (9.9)			11.2 (15)			13.5 (18)		
Max. Operation Range	4,500~5,300 rpm			4,750~5,500 rpm					
Number of Cylinder	2								
Piston Displacement, cc (in ³)	247 (15.1)						294 (17.9)		
Bore x Stroke, mm (in)	55 x 52 (2.17 x 2.05)						60 x 52 (2.36 x 2.05)		
Exhaust System	through hub exhaust								
Lubrication	engine oil mixed gasoline								
Cooling System	forced water cooling								
Starting System	manual	electric starter motor		manual	electric starter motor		manual	electric starter motor	
Ignition	breaking pointless C.D. ignition								
Ignition Plug	NGK B7HS-10 or CHAMPION L82C (gap 1.0 mm) (0.039 in.)								
Trim Stages	6								
Engine Oil Mixing Ratio	unleaded gasoline 50: Genuine Tohatsu Engine Oil 1								
Gear Oil	Genuine Tohatsu Gear Oil (GL5 SAE #80~90)								
Fuel Tank Capacity, / (U.S. gals)	22.7 (6)								
Gear Reduction Ratio	13 : 24								

*: option in factory

2. NOMENCLATURE

M9.9C/M15C/M18D

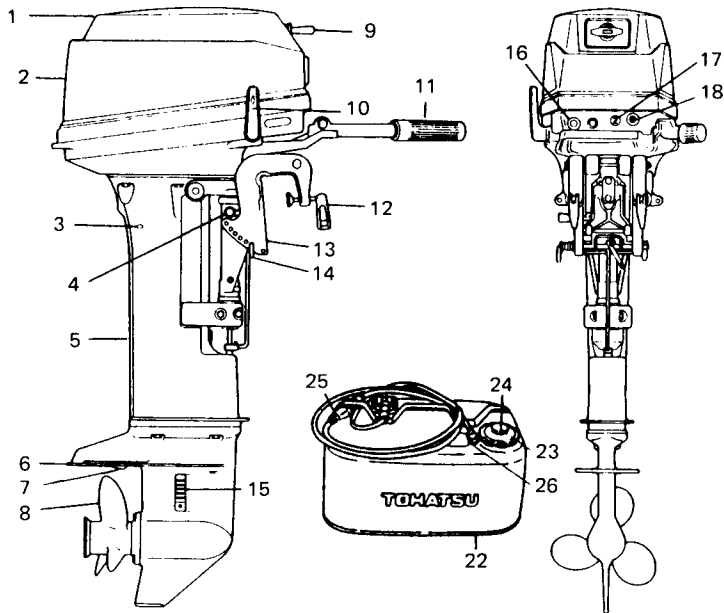

- (1) Tilt Handle
- (2) Upper Motor Cover
- (3) Cooling Water Check Port
- (4) Tilt Stopper
- (5) Drive Shaft Housing
- (6) Anti-Cavitation Plate
- (7) Sub Water Strainer
- (8) Propeller
- (9) Starter Handle
- (10) Shift Lever
- (11) Throttle Grip
- (12) Clamp Screw
- (13) Stern Bracket
- (14) Thrust Rod
- (15) Water Strainer
- (16) Stop Switch
- (17) Choke Knob
- (18) Connector B
- (19) Oil Plug (Upper)
- (20) Oil plug (Lower)
- (21) Water Plug
- (22) Fuel Tank
- (23) Fuel Tank Cap
- (24) Air Vent Screw
- (25) Primer Bulb
- (26) Fuel Connector

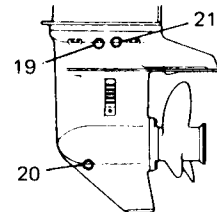

M9.9CEF/M15CEF/M18DEF

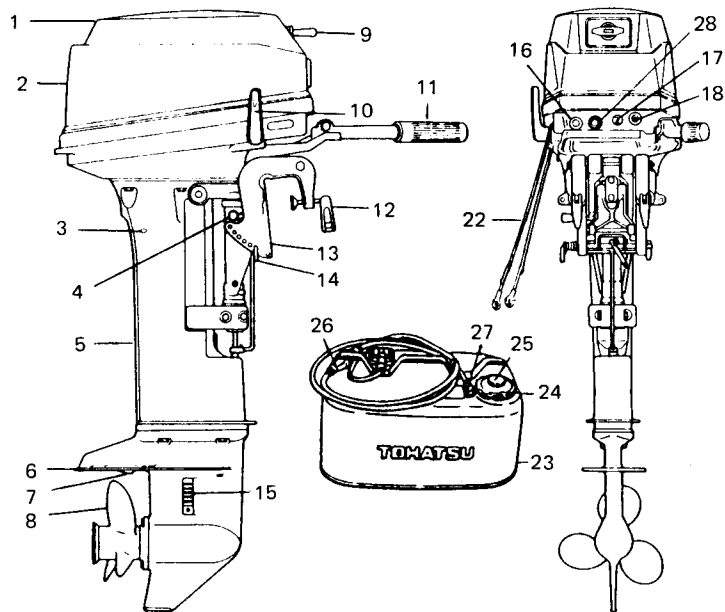

- (1) Tilt Handle
- (2) Motor Cover Upper
- (3) Cooling Water Check Port
- (4) Tilt Stopper
- (5) Drive Shaft Housing
- (6) Anti-Cavitation Plate
- (7) Sub-Water Strainer
- (8) Propeller
- (9) Starter Handle
- (10) Shift Lever
- (11) Throttle Grip
- (12) Clamp Screw
- (13) Stern Bracket
- (14) Thrust Rod
- (15) Water Strainer
- (16) Stop Switch
- (17) Choke Knob
- (18) Connector B
- (19) Oil Plug (Upper)
- (20) Oil Plug (Lower)
- (21) Water Plug
- (22) Battery Cord
- (23) Fuel Tank
- (24) Fuel Tank Cap
- (25) Air Vent Screw
- (26) Primer Bulb
- (27) Fuel Connector
- (28) Main Switch

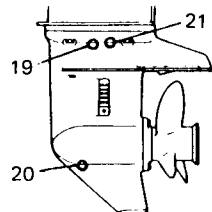

M9.9CEP/M15CEP/M18DEP

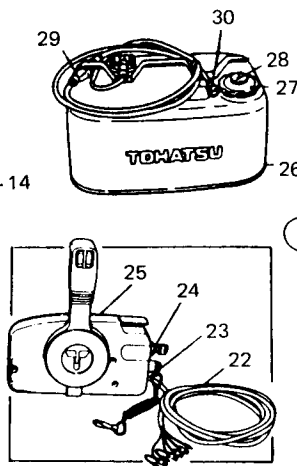
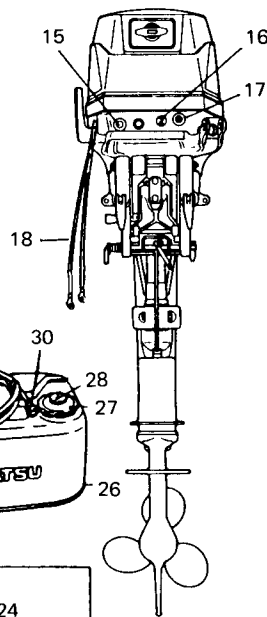
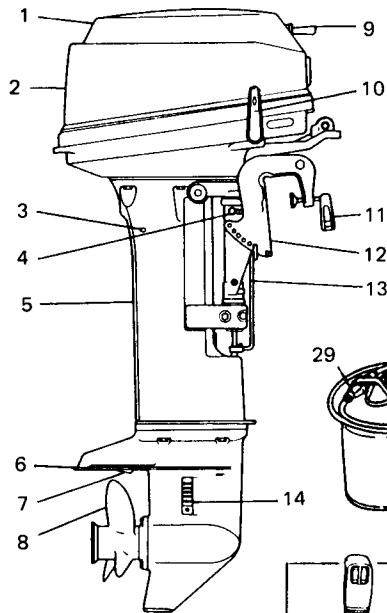

- (1) Tilt Handle
- (2) Motor Cover Upper
- (3) Cooling Water Check Port
- (4) Tilt Stopper
- (5) Drive Shaft Housing
- (6) Anti-Cavitation Plate
- (7) Sub-Water Strainer
- (8) Propeller
- (9) Starter Handle
- (10) Shift Lever
- (11) Clamp Screw
- (12) Stern Bracket
- (13) Thrust Rod
- (14) Water Strainer
- (15) Stop Switch (Option)
- (16) Choke Knob
- (17) Connector B
- (18) Battery Cord
- (19) Oil Plug (Upper)
- (20) Oil Plug (Lower)
- (21) Water Plug
- (22) Cord Assembly
- (23) Main Switch
- (24) Stop Switch
- (25) Remote Control Box
- (26) Fuel Tank
- (27) Fuel Tank Cap
- (28) Air Vent Screw
- (29) Primer Bulb
- (30) Fuel Connector

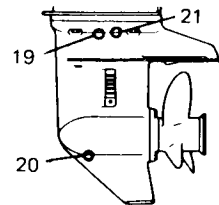

3. INSTALLATION

WARNING

Most boats are rated and certified in terms of their maximum horsepower limit, and this is shown on the boat's certification plate. Do not equip your boat with an outboard that exceeds this limit. If in doubt, contact your dealer.

Do not operate the engine unit if it has been securely mounted on the boat in accordance with the instructions below.

3-1. Mounting the engine on boat

- (1) Setting position above keel line
Distance between engines (Fig. 1)
approximately 580 mm (22.8")

- (2) Transom matching

Be sure that the anti-cavitation plate of the outboard is below the water surface when running with wide open throttle.

In case the above condition cannot be met due to a bottom shape of your boat, please consult the TOHATSU dealer. (Fig. 2)

- (3) Tighten engines to boat by clamp screw handle and bolt of engine bracket. Tighten engines to boat to prevent loss. (Fig. 3)

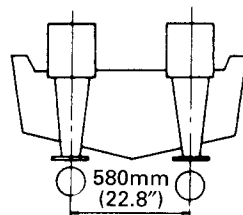

Fig. 1 Twin engine mounting

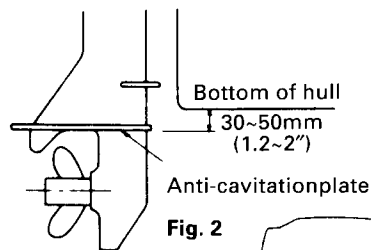

Fig. 2

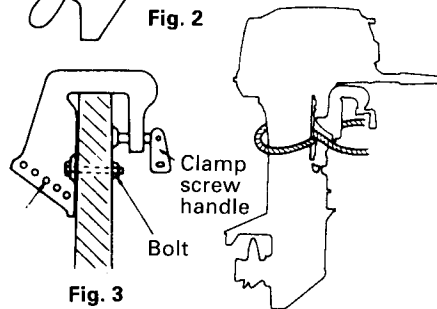

Fig. 3

(4) Trim angle

The outboard motor is adjustable its trim angle depending on stern angle of a boat and loading condition. Choose appropriate trim angle of the motor that the anti-cavitation plate is parallel to water face while running.

●Proper trim angle

When the boat is horizontal while running, a position of the thrust rod is proper.

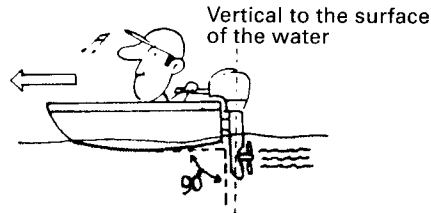

●Improper trim angle

Set the thrust rod lower.

If a bow of a boat is rising, having heavy pitching or unstable straight running, set the thrust rod lower.



●Improper trim angle

Set the thrust rod upper.

If a bow of a boat goes under a wave, set the thrust rod upper.

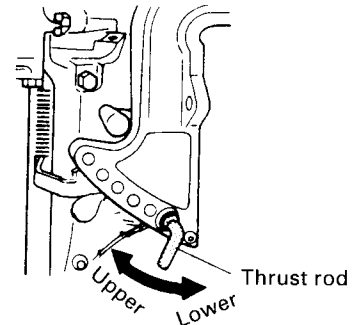

3-2. Installing the remote control device

Explanation of right hand Remote Control Box is written in this book.

(1) Installation position of the Remote Control Box and length of the Remote Control Cable.

- ① Position of the Remote Control Box
Decide installation position for the Remote Control Box where there is no obstruction to operate the Remote Control Lever and switches.
Check if there is obstruction on the way of the Remote Control Cables.
- ② Length of the Remote Control Cable

Note: Do not bend the Remote Control Cable smaller than 406 mm (16 inches) with a diameter.

(2) Installation of the Remote Control Cable (the Box side)

- ① Take out the back panel of the Remote Control Cable by loosening two screws.
- ② Screw the Remote Control Cable Terminal Eye (1) more than 11 mm (0.43 inch).
Hold the Terminal Eye by a nut (2) for not turn the Terminal Eye.

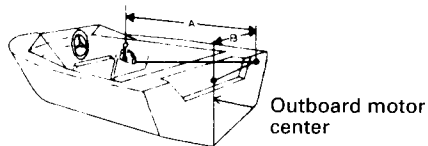
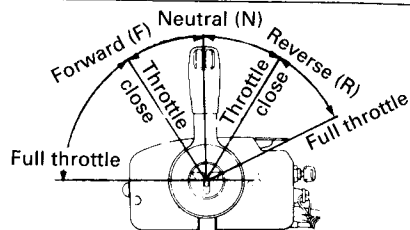
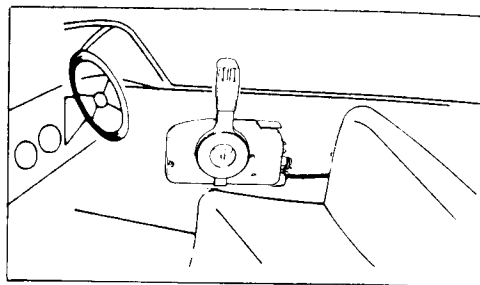
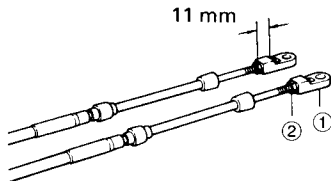
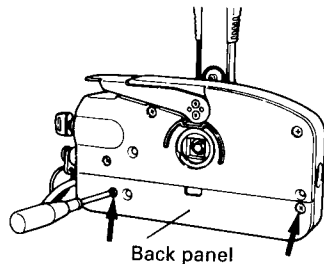

- ③ Set the Shift Remote Control Cable outer groove into the Housing groove.
Set the Terminal Eye on the pin of the Shift Arm and fix it with E-ring.
- ④ Insert attached grommet to the clamp groove of the Remote Control Box.
- ⑤ Install the Throttle Remote Control Cable to the Throttle Arm.
- ⑥ Install the Back Panel of the Remote Control Box.
- ⑦ After installation of the Remote Control Cable, mount the Remote Control Box by using attached screws, spacers, washers and nuts (each 3).

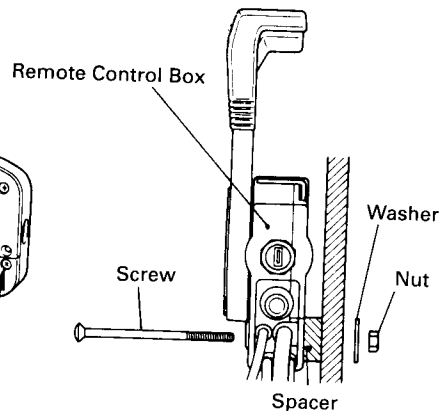
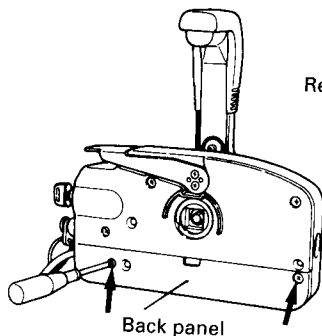
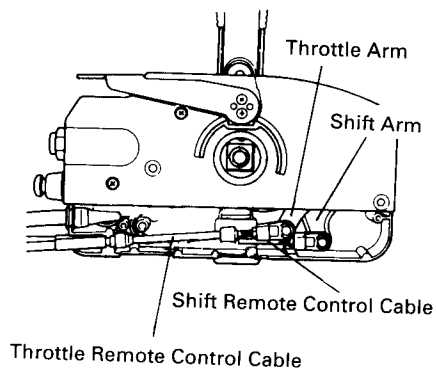
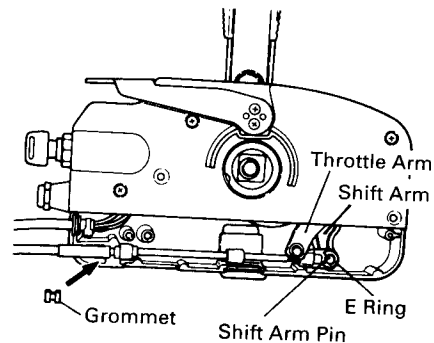

(3) Fitting of the Remote Control Cable (engine side) and the Cord Assembly

- ① Fit the attached fitting parts according the drawing below before fit the Remote Control (engine side)

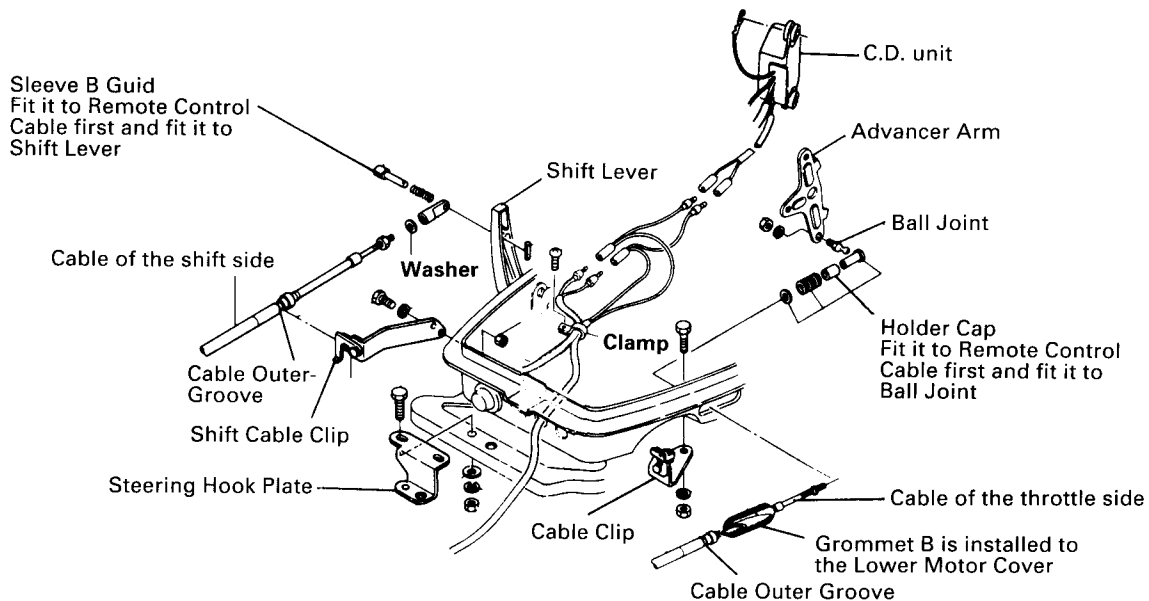

② Fitting of the Holder Cap and Sleeve B Guide

- Throttle side Insert the cable to the attached grommet and install the holder cap to the end tip of the cable and fix it by the nut.
- Shift side Fit the sleeve B guide to the end tip of the shift cable.

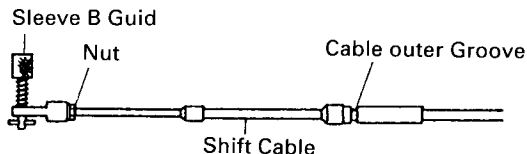
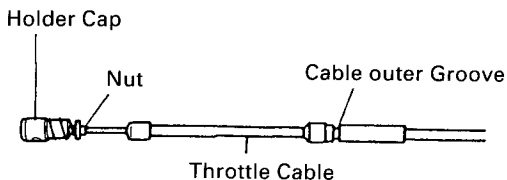

③ Fitting of the Remote control cable engine side

- Throttle side
Insert the throttle cable to the hole provided in the Motor cover lower.
Fit the holder cap of the end tip of the cable to the ball joint.
Set the cable outer groove portion to the cable clip to fix the cable.
Re-install the grommet B to the motor cover lower.

Note: Set the control lever to Neutral position and the free accelerator lever to fully closed position.

- Shift side
Insert the lock pin of the sleeve B guide at the end tip of the cable to the shift lever fitting hole and turn it 90° to lock.
Insert the cable outer groove to the shift cable clip to fix.

3-3. Mounting the battery

- (1) Locate the battery box in a convenient position away from possible spray damage. Securely fasten both the box and battery so they do not shake loose.

A 12 V battery with a recommended capacity of 40 AH or over is recommended.

Note:

- (1) Use battery leads having sufficient length.
- (2) Make sure that the battery leads are not trapped between motor and boat when turning, etc.
- (3) If leads are incorrectly connected, the starter may fail to operate.
- (4) Be sure to connect (+) and (-) leads correctly. If they are mis-connected, charging system will be damaged.
- (5) Always use fully charged battery.

- (2) Connect the positive lead (+) to the positive terminal (+) of the battery, and then connect the negative lead (-). When disconnecting the battery always remove the negative lead (-) first. After connection of (+) terminal, cover a cap on the positive terminal (+) to prevent short circuits.

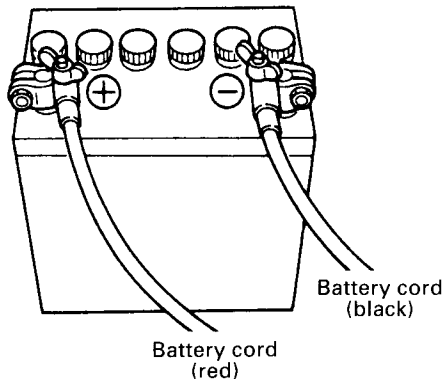

4. PREPARATION BEFORE OPERATION

4-1 Fuel oil

- Confirm that enough engine oil mixed gasoline is on board for a day engine operation.
Shortage of fuel oil at off shore leads to big accident and having another tank with fuel oil is recommended.

- Mixing ratio (50:1)

unleaded gasoline 50: GENUINE TOHATSU ENGINE OIL

or

recommended engine oil (TCW3) 1

Break-In Running must be carried for 10 hour with mixing ratio 25:1 fuel oil

- Use of low quality gasoline brings not only short engine life but starting failure or cause of engine trouble.

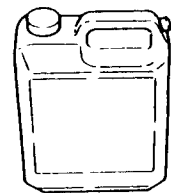

TOHATSU ENGINE OIL



TOHATSU ENGINE OIL

● FUEL AND LUBRICANT FOR TOHATS OUTBOARD MOTORS

Gasoline

Premium (super) gasoline is highly recommended for TOHATSU Outboard motors.

Fuel gasoline should be a minimum pump posted octane rating of 87 (91 by research octane rating).

Note:

Gasoline containing alcohole, methanol (methyl), or ethanol (ethyl), may cause:

- Wear and damage on bearings, piston, piston rings and cylinder liners.
- Corrosion on metal parts.
- Deterioration of rubber parts and plastic parts.

Engine Oil

Use a genuine TOHATSU engine oil or recommended one (TCW3). TOHATSU will not recommend use of other two stroke engine oil.

Caution

Do not mix different brands of oil.

The mixing of different brands of oil or different kinds of oil even in same brand may cause jelling (gel), resulting in blockage of filter screens.

This may lead to serious engine damage, due to the lack of powerhead lubrication.

4-2 Break-in Running

1) Break-in running time 10 hours

Time	0 min.~	10 min.~	1 hr.~	2 hrs.~	10 hrs.~
Method of break-in run	Trolling or idling	Throttle opening < 1/2 about 3,000 rpm	Throttle opening < 3/4 about 4,000 rpm	Throttle opening 3/4 about 4,000 rpm	Normal runing
Running conditions	Cruising at minimum speed		Full-throttle run is allowed for 1 min. in 10 min.	Full-throttle run is allowed for a short time.	

2) Fuel mixing ratio

Gasoline 25: Tohatsu Engine Oil 1

- 25:1 when using genuine TOHATSU engine oil or recommended one (TCW3)
TOHATSU will not recommend use of other than genuine TOHATSU engine oil or recommended one (TCW3).

- The use of poor quality fuel will shorten the life of a motor and cause trouble, including starting failure. It is recommended to use a high quality gasoline and genuine or recommended Engine Oil.

5. RUNNING

5-1. to Start

(1) Preparation to start

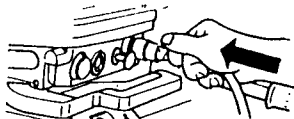

- ① Set the fuel connector to the engine side connector. An arrow mark on the primer valve is to be lead to the engine.



- ② Loose the air vent screw on the tank cap.

For tanks with a fuel tank auto air-vent. (optional)
There is no need to loosen the air vent screw. An air vent opens automatically when the connector is attached to the tank.

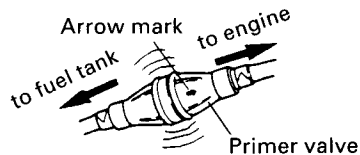

- ③ Feed fuel to the carburetor by squeezing the primer valve until firm.

Note: Do not operate Engines without cooling water.

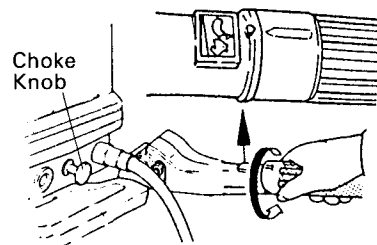
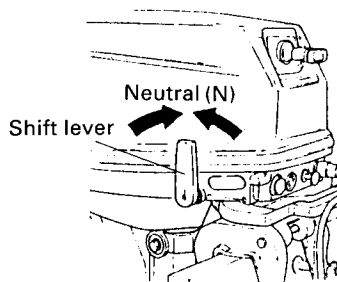

Be sure that the shift is at neutral when starting the engine.
This model is provided with start in-gear protection.

CAUTION

If motor starts in gear, do not use, contact your authorized TOHATSU dealer.

Fit the lock in the stop switch.

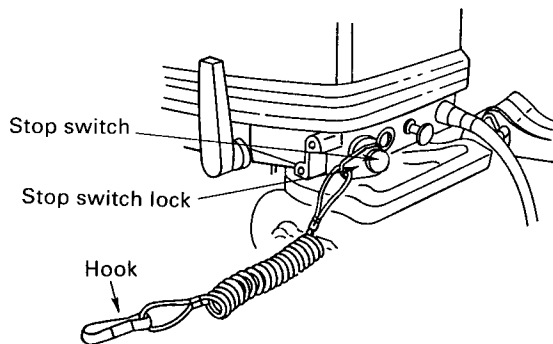

WARNING

Be sure to connect the emergency stop lanyard to your body. The engine will shut down if the stop lanyard is disconnected.

Note: The engine will not start unless this switch has been properly connected and locked beforehand.

WARNING-Daily Check

Before moving out with the boat, confirm that the emergency stop switch works normally by starting and stopping the engine several times.

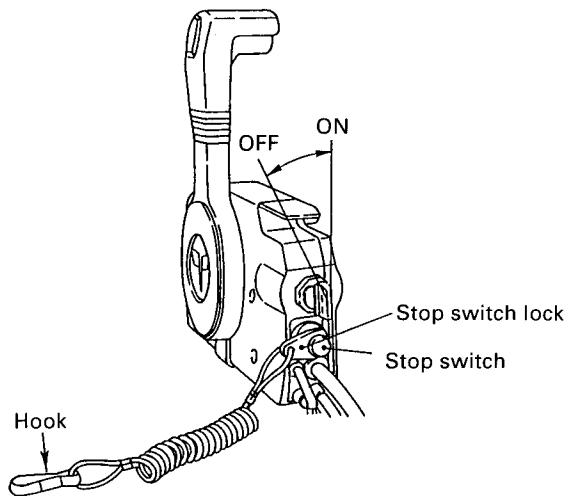

M9.9C/M15C/M18D and EF type

- (1) Place the shift lever in the Neutral position.
- (2) Turn the handle grip until the bar mark on the grip faces the tri-angle mark on the steering handle.
- (3) Pull out the choke knob fully.
(No choke operation is necessary on warmed engine.)

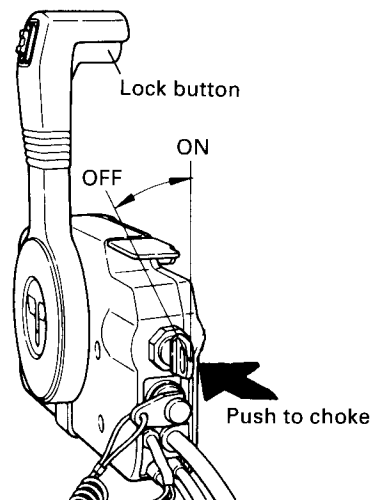
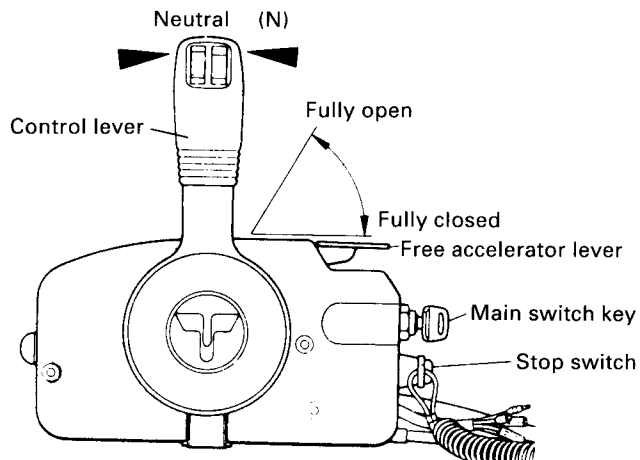

- (1) Insert the main switch key.
- (2) Set the control lever in Neutral position.
Raise up the free accelerator lever.
- (3) Turn the main switch key one stage.
When the key is pushed in this condition, it works the choke.
(No choke operation is necessary on warmed engine.)

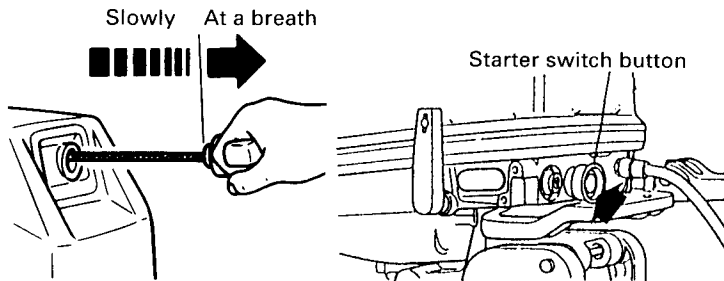

EF type

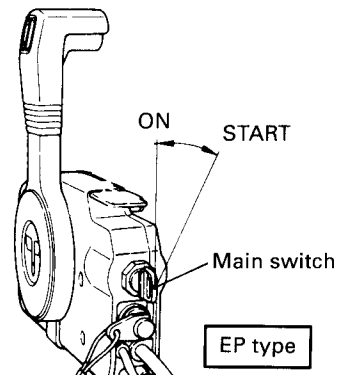

EP type

(2) Starting

M9.9C/M15C/M18D

- Pull the starter handle slowly until you feel resistance, then pull it at a breath.

EF type

- Push the starter switch button.
- Release hand from the button when after the engine is started.

EP type

- Turn the main switch key to START position with keeping pushing the key to choke.

Note: On warmed engine, turn the main switch key without choke operation.

- Release hand from the key when after the engine is started.
The key returns to original position automatically.

Note: EF-EP type "IMPORTANT"

Continuous long time operation of the starter motor makes short battery life.

Operate the starter motor for maximum 3 seconds. If the engine does not start, wait for 5 seconds before operating the starter motor again or starter will be damaged.

Do not operate the starter motor when after the engine is started.

(3) If the recoil starter or starter motor fails to operate

- ① Remove recoil starter cover and pull starter rope directly.
- ② Use a 10 m/m socket wrench as a hand on the rope grip.

CAUTION

Be careful that your clothes or other items do not get caught in the rope or other engine parts. To prevent your clothes and other items from getting caught in the engine, do not install the recoil starter nor the upper engine cover after the engine is started with the starter rope. Immediately contact an authorized TOHATSU service shop when reaching shore.

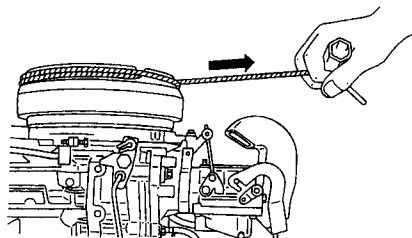

5-2 warming up engine

Warm the engine with low engine speed for about three minutes before clutch in. This allows the lubricating oil to circulate to all parts of the engine. If the warming engine will not be carried, the life of the engine goes shorter.

Be sure to check that cooling water is coming out from the water check port while warming the engine up.

If engine operation will be continued in a condition of no discharging water from the water check port nor idle hole, there is a possibility of engine over heat.

- Engine speeds
Idling speed when warming up.

Engine model	Clutch in	Clutch off
M9.9C/M15C/M18D and EF/EP	600~700 rpm	800~900 rpm

PROPELLER SELECTION

A propeller must be selected so that the engine rpm measured at wide open throttle while cruising is within the recommended range.

model	Full throttle rpm range
M9.9C	4,500~5,300 rpm
M15C/M18D	4,750~5,500 rpm

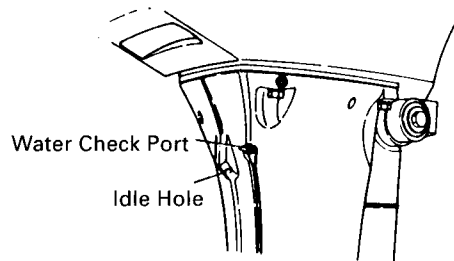

5-3. forward and reverse

WARNING

**It may be dangerous to attempt shifting at high RPM.
Be sure to slow down to trolling or idling rpm before shifting.**

M9.9C/M15C/M18D and EF Type

(1) Forward

Reduce the engine r.p.m until trolling speed when shift the clutch.

Turn the handle grip to low speed. After the engine r.p.m becomes to trolling speed, operate the shift lever quickly to Forward.

(2) Reverse

As well as shifting to Forward, reduce the engine r.p.m to trolling, operate the shift lever quickly to Reverse.

Setting reverse lock is done only in reverse shift position automatically by moving shift lever.

Do not increase the engine speed excessively while reversing.

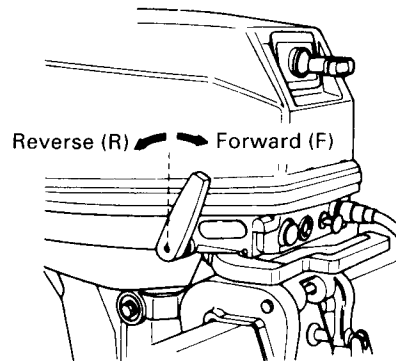

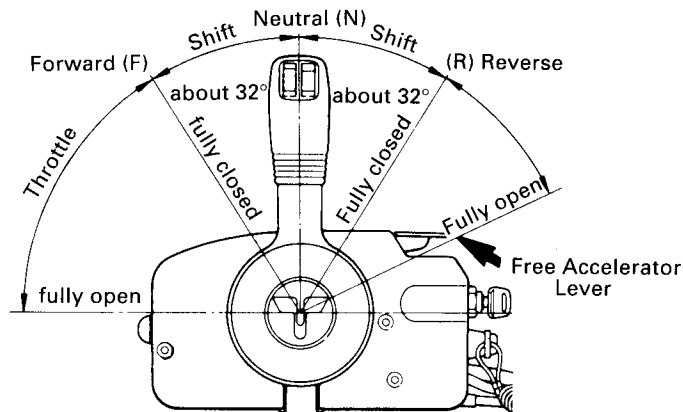

EP type

- (1) Forward
Swiftly shift the control lever to Forward (F) at 32° where the lever is latched automatically, while lifting up the lock button located at the bottom of the control lever grip. Further shifting will open the throttle.
- (2) Reverse
Swiftly shift the control lever to Reverse (R) at 32° where the lever is latched automatically, while lifting up the lock button located at the bottom of the control lever grip. Further shifting will open the throttle.

Note: The Control Lever is inoperative unless the Free Accelerator Lever is in the fully closed position.

Note: • Reduce the engine speed properly when the Control Lever is in "Neutral" position and do not increase the engine speed unnecessary.

5-4. stopping

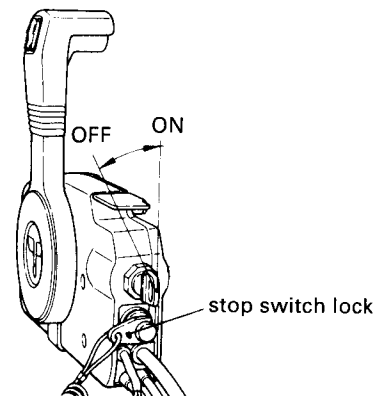
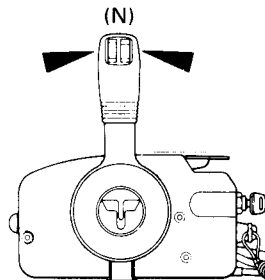
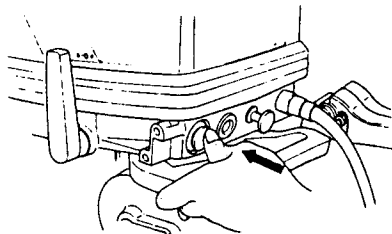

M9.9C/M15C/M18D/EF type

- (1) Turn the throttle grip to low speed position.
- (2) Set the shift lever to Neutral position.
Run the engine for 2~3 minutes at idling speed if it has been running at full speed.
- (3) Press stop switch to stop engine.

EP type

- (1) Set the shift lever to Neutral position and run the engine 2~3 minutes at idling speed.
- (2) Turn the main switch key to OFF position or pull out the stop switch lock.

Note:

- After the engine stopped, close the air vent screw on the tank cap.
- Disconnect the fuel connector of the engine or the fuel oil tank.
- Disconnect the battery cord of EF or EP type engine, when the engine will not be used for days.

5-5. tilt up, tilt down

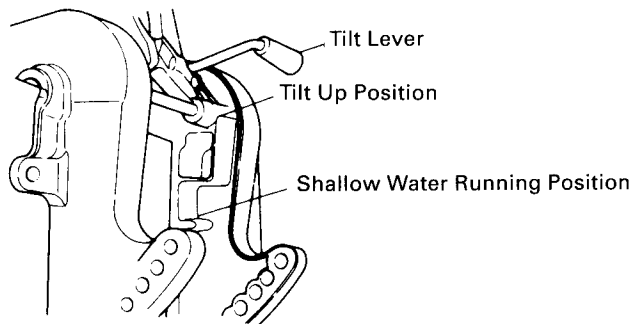
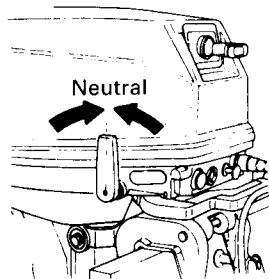

Releasing reverse lock is done in Neutral and Forward shift position automatically by moving shift lever.

(1) Tilt up

Set the Shift Lever to Neutral position, and tilt up the engine.
Fix the engine by pushing down the Tilt Lever.

(2) Tilt down

Pull the Tilt Handle of Motor Cover Upper upward slightly.
Move the Tilt Lever upward and tilt down the engine.

DANGER

**When tilting up or down, be sure that no finger or hand is placed in between the swivel bracket and stern bracket.
Be sure to tilt down the outboard slowly.**

5-6. shallow water running

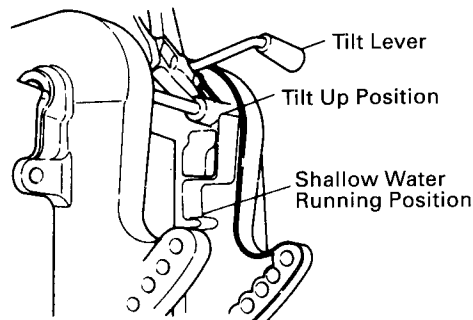
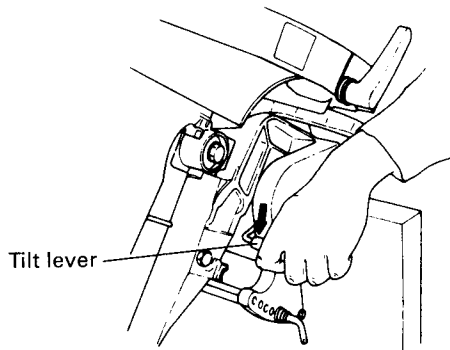

(1) Shallow water running position

Set the Shift Lever neutral.

Tilt up the engine and set to shallow water running position by pushing down the tilt lever.

(2) Tilt down from shallow water running position

Pull the Tilt Handle of Motor Cover Upper upward slightly to release from shallow water running position and tilt down the engine.

CAUTION

- When in shallow water running, take care that the water strainer is submerged at all times and that water is continuously running out of the cooling water check port.
- Be sure to run slowly when using the shallow water drive. Running at higher speeds will result in lack of control and may cause damage the gear case.
- Make sure that the motor does not strike the bottom, especially when running in REVERSE. If the motor strikes the bottom while reversing, the impact is transmitted to the transom, risking damage to both the motor and the boat.

6. REMOVING THE MOTOR

- 1) Stop the engine.
- 2) Disconnect the fuel pipe connector from the motor.
- 3) Remove the motor from the hull and completely drain water from gear case.
Be sure to keep the engine higher than the propeller whenever you carry the motor.
- 4) Lay the engine down on the ground with the handles facing upward.

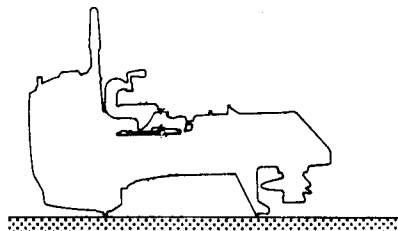
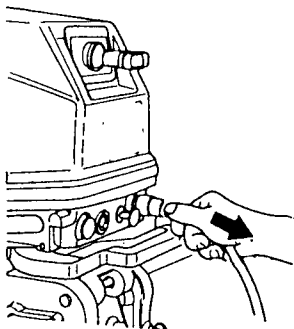

7. STEERING FORCE ADJUSTMENT

Steering force is adjustable according to your preference with the steering adjust bolt.

for heavier steering turn clockwise

for lighter steering turn counterclockwise

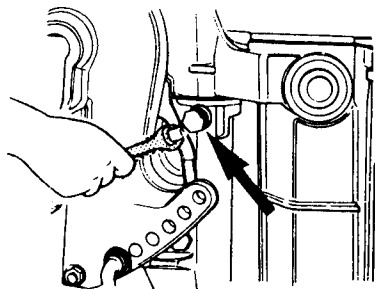

8. INSPECTION AND MAINTENANCE

8-1. Daily Inspection Checklist

Perform the following checks before and after use.

Item	Points to Check	Action
Fuel System	<ul style="list-style-type: none"> Check the amount of fuel in the tank. 	Replenish
	<ul style="list-style-type: none"> Check for dust or water in the fuel filters. 	Clean
	<ul style="list-style-type: none"> Check rubber pipes for oil leakage 	Replace
Electrical Equipment	<ul style="list-style-type: none"> Check that the main switch functions normally. 	Remedy or replace
	<ul style="list-style-type: none"> Check that the battery electrolyte level and specific gravity are normal. 	Replenish or recharge
	<ul style="list-style-type: none"> Check for loose connections on battery terminal. 	Retighten
	<ul style="list-style-type: none"> Check that the emergency stop switch functions normally and makes sure the lock plate is present. 	Remedy or replace
	<ul style="list-style-type: none"> Check cords for loose connections and damage. 	Correct or replace
Throttle System	<ul style="list-style-type: none"> Check the spark plugs for dirt, wear and carbon built-up. 	Clean or replace
	<ul style="list-style-type: none"> Check that the choke solenoid and valve for the carburetor works normally. 	Replace

Item	Points to Check	Action
Throttle System	<ul style="list-style-type: none"> Check if the carburetor and magneto work normally when turning the throttle grip, and also check links for looseness. 	Correct
Recoil Starter	<ul style="list-style-type: none"> Check ropes for wear and damage. 	Replace
	<ul style="list-style-type: none"> Check the latchet for engagement. 	Correct or replace
Clutch and Propeller System	<ul style="list-style-type: none"> Check that the clutch engages correctly when operating the shift lever and remote control. 	Adjust
	<ul style="list-style-type: none"> Visually check the propeller for bent or damaged blades. 	Replace
	<ul style="list-style-type: none"> Check that the propeller nut is tightened and the split pin is present. 	
Installation of Motor	<ul style="list-style-type: none"> Check all the motor installation bolts with the boat. 	Tighten
	<ul style="list-style-type: none"> Check the thrust rod installation. 	
Cooling Water	<ul style="list-style-type: none"> Check that cooling water is discharged from the cooling water check port after the engine has started. 	
Tools and Spares	<ul style="list-style-type: none"> To be ready tools and spare parts for replacing spark plugs, propeller, etc. 	
	<ul style="list-style-type: none"> Check if the spare rope is provided. 	
Steering Devices	<ul style="list-style-type: none"> Check working of steering handle and remote control. 	
Other parts	<ul style="list-style-type: none"> Check if the anode is securely installed. 	Repair if necessary.
	<ul style="list-style-type: none"> Check the anode for corrosion and deformation. 	Replace

1) Washing

After use in sea water or polluted water, wash all enclosures and water cooling system with fresh water.

- Remove the water plug from the motor, and screw in the associated flushing plug (hose adapter).

Connect a hose to the flushing plug to flush out the inside of the motor with water. (Be sure to seal the water strainer and sub water strainer, located at the gear case, with tape.)

IMPORTANT: Before washing through the flushing plug, remove the propeller.

Before long-term storing, wash the motor.

- With the shift lever in Neutral (N), run the engine at a low speed so that water flushes out the cooling system to remove sea water and mud.

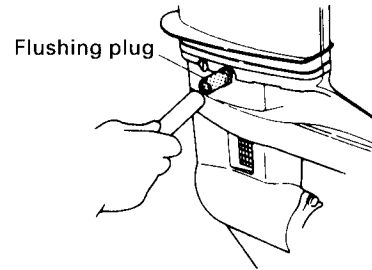

2) Replacing the propeller

A worn-out or bent propeller will deteriorate the motor's performance, and cause engine trouble.

- Withdraw split pin, and remove propeller nut and washer.
- Pull the propeller toward you and remove it.
- Apply genuine Tohatsu grease to the propeller shaft before mounting a new propeller.

IMPORTANT: Before removing the propeller, remove the spark plug cap to protect the propeller from damage.

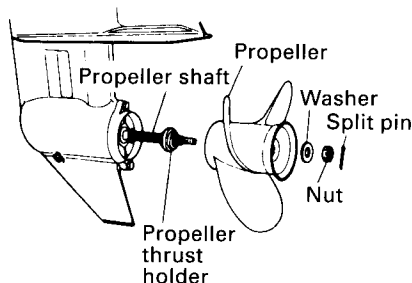

3) Replacing the spark plug

If the electrode is fouled or has carbon deposits, clean or replace it with a new one as necessary.

- Remove the engine cover.
- Remove the spark plug by turning counter-clockwise while tapping it gently, using a 17 mm socket wrench and handle.

Use genuine TOHATSU spark plugs (NGK B7HS-10 or BR7HS-10) or recommended ones (CHAMPION L 82 C with gap 1.0).

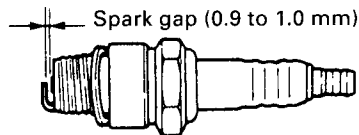

4) Replacing the anode

When the anode, provided at the anti-cavitation plate, has been eroded to the dimensions shown below, replace it with a new one immediately.

Unit: mm (in)

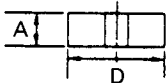
	Dimensions						
		A	B	C	D	E	F
	New anode	7.8 (0.307)			24 (0.945)		
	Lower limit size	7.0 (0.276)			18.5 (0.728)		

IMPORTANT:

- Never grease or paint the anode.
- At each inspection, retighten the anode fixing bolt, since it is likely to be subjected to electrolytic corrosion.

8-2. periodic Inspection Checklist

It is important to inspect and maintain your outboard motor regularly. At each interval on the chart below, be sure to perform the indicated servicing. Maintenance intervals should be determined according to the number of hours or number of months, whichever comes first.

Item		Servicing Interval			Action	Remarks
		10 hours or 1 month	50 hours or 3 months	Every 100 hours or 6 months		
Fuel System	*Carburetor	○		○	Strip, clean and adjust. Adjust idling.	
	Fuel filter	○	○	○	Check and clean.	
	Piping			○	Check and clean.	
	Fuel tank	○	○	○	Clean	
Ignition	Spark plugs	○	○	○	Check gaps. Remove carbon deposits.	
	*Ignition timing	○		○	Adjust timing.	
Starting System	*Starter motor			○	Check for salt deposits and battery cable condition.	
	Battery	○	○	○	Installation, fluid quantity, gravity	

Item		Servicing Interval			Action	Remarks
		10 hours or 1 month	50 hours or 3 months	Every 100 hours or 6 months		
Starting System	Starter rope	○	○	○	Check for wear or damage	
Lower Unit	Propeller	○	○	○	Bend of blades damage, wear	
	Gear oil	○	○	○	Change of oil or replenishment and water leak	
	Water pump		○	○	Check for wear or damage	Replace impeller every 12 months
Bolts and Nuts		○	○	○	Retighten	
Sliding and Rotating Parts. Grease Nipples.			○	○	Apply and pump in grease.	
Outer Equipment		○	○	○	Check corrosion	
Anode			○	○	Check corrosion and deformation	Replace

For checking the items marked with *, consult with the TOHATSU dealer.

Changing gear oil

- 1) Remove oil plugs (upper and lower), and drain gear oil completely.
- 2) Insert an oil tube nozzle into the lower oil plug hole, and fill gear oil by squeezing the oil tube until oil flows out of the upper plug hole.

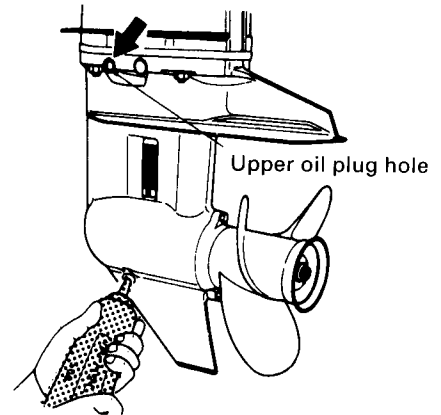
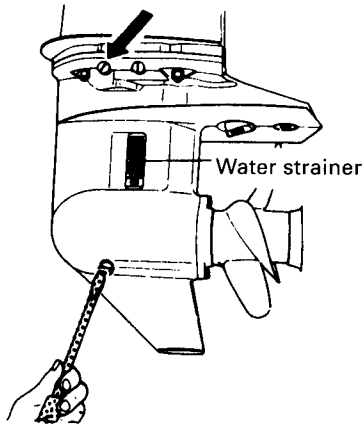

NOTE: Use a genuine TOHATSU gear oil or recommended one (GL-5: SAE #80 to #90).

- 3) Install the upper oil plug, and then remove oil tube nozzle and install the lower oil plug.

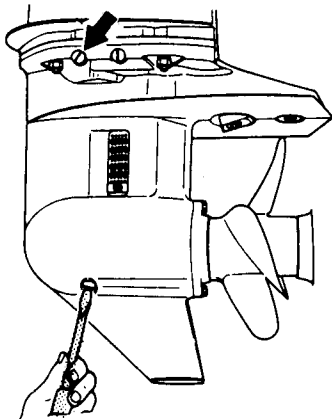

Cleaning the fuel tank and the filters

Fuel filters are provided inside the fuel tank and at the engine.

- Unscrew four screws, remove the housing, and then clean the fuel filter.

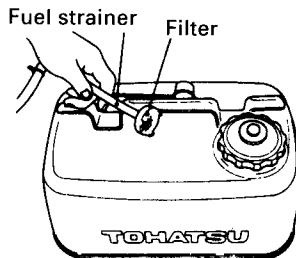

- Remove the cap, then clean the fuel filter at the engine.

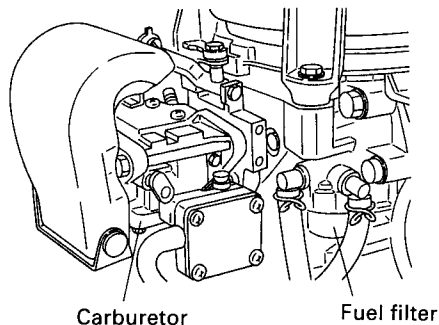

Cleaning fuel tank

Water or dirt in the fuel tank may cause engine trouble.

Clean the tank at specified times or after long time storage (over three months).

8-3. Winter storage

WARNING

1. When the motor is out of the water, being transported or in storage, always remove the positive (+) battery cable to prevent accidental starting of the engine. Accidental starting when the motor is out of the water will cause water pump failure, overheating and damage to the engine due to a lack of cooling water.
2. DO NOT disconnect the electrical harness when operating the motor. This model will continue to run and can be started with the electrical harness disconnected. Remove all spark plug connectors from the spark plugs when servicing the engine or propeller.

When your outboard motor is in storage, this is a good opportunity to have it serviced and overhauled by your TOHATSU dealer.

(1) Engine

- ① Wash the engine exterior and flush the cooling water system thoroughly with fresh water. Let the water drain completely.

Wipe off any surface water with an oily rag.

- ② Drain all fuel from the fuel pipes, fuel pump and carburetor, and clean these parts. To prevent corrosion of the fuel tank, fill it up with engine oil-rich gasoline.

Keep in mind that if gasoline is kept in the carburetor for a long time, gum and varnish will be generated, causing the float valve to stick.

- ③ Remove the spark plugs and feed genuine Engine Oil or storage fogging oil through the spark plug holes.

The oil will be fed into the crank case from the air silencer attached to the carburetors. Turn the engine over several times while feeding the oil into it and make sure it is evenly distributed.

- ④ Apply grease to the propeller shaft.
- ⑤ Change the gear oil in the gear case.
- ⑥ Apply grease to all sliding parts, joints, nuts and bolts.
- ⑦ Use a dry cloth to completely wipe off water and salt from the electrical compo-

nents.

- ⑧ Remove the fuel connector from the engine.
- ⑨ Stand the engine vertically in a dry place.

(2) Battery

- ① Disconnect the battery cables.
- ② Clean the exterior of the battery with fresh water or compressed air.
Wipe off any chemical deposits, dirt and grease from the battery.
- ③ Apply grease or vaseline to the battery terminals.
- ④ Charge the battery completely before storing it for the winter.
- ⑤ Recharge the battery once a month to prevent it from discharging and the electrolyte from deteriorating.
- ⑥ Store the battery in a dry place with its cover attached.

CAUTION

1. Do not allow the battery to discharge, since it can be damaged by freezing.
2. When storing your outboard for the winter, open up all the water drain holes in the gear case to permit any remaining water to drain out. If a speedometer is installed, disconnect the pickup tube and allow it to drain, then reconnect it after draining. Trapped water may crack the gear case or water pump case as a result of expansion when frozen. Check and replenish the gear case with case specified Gear Oil before storing the motor, to avoid water leakage into the gear case due to a loose lubricant vent plug or grease fill plug. Inspect the gaskets under the lubricant vent and grease plugs, replace them if necessary, and reinstall the plugs.

(3) Electric Starter Motor

Coat the pinion gear and shaft of the electric starter motor with grease.

8-4. pre-season check

- ① Check the electrolyte level, and measure the voltage and specific gravity of the battery.

Specific Gravity at 20°C	Terminal Voltage (V)	Charge Condition
1.120	10.5	Fully discharged
1.160	11.1	1/4 charged
1.210	11.7	1/2 charged
1.250	12.0	3/4 charged
1.280	13.2	Fully charged

- ② Check that the battery is secure and the battery cables installed properly.
- ③ Check that the shift and throttle function properly.
(Be sure to turn the propeller shaft when checking the shift function or else the shift linkage may be damaged.)

CAUTION

The following steps must be taken when first using the engine after winter storage.

1. Fill up the fuel tank completely with 22.7 liters (6 U.S. gals.):
Mixing ratio: Gasoline 25:1 Engine oil
Use premium (super) gasoline and genuine TOHATSU Outboard Motor Oil. If this oil is not available, use NMMA TC-W 3 certified outboard motor oil.
2. Warm up the engine for 3 minutes in "NEUTRAL" position.
3. Run the engine for 5 minutes at the slowest speed.
4. Run the engine for 10 minutes at half speed.

In steps 2 and 3 above, the oil used for winter storage inside the engine will be cleaned out, and optimum performance will be assured.

8-5. submerged motor in water

After picking up, immediately bring the outboard to your TOHATSU dealer.

Following are the emergency measures to be taken on the submerged outboard.

- 1) Take it out of the water immediately, and wash it with fresh water to remove salt or dirt.
- 2) Remove the spark plug, and completely drain water from the engine by pulling the recoil starter several times.
- 3) Sufficiently inject genuine Tohatsu engine oil through the spark plug hole and into the crank case from the carburetor side. Pull the recoil starter several times to circulate the oil throughout the motor.

8-6. precautions in cold weather

If you cruise and moor your boat in cold weather as sub-zero temperatures, there is a danger of water freezing in the cooling water pump, which may damage the pump, impeller, etc. To avoid this, submerge the lower half of the motor into water, or pull the recoil starter several times to

drain water completely, with the motor tilted up.

8-7. Checking after striking underwater object

Striking sea bottom or underwater object may severely damage the outboard. Immediately bring the outboard to the TOHATSU dealer and ask for the following checks.

(1) Looseness or damage of power unit installation bolts, gear case and extension case bolts, propeller shaft housing bolts, upper and lower mount rubber bolts and mount Bracket bolts.

Ask to tighten loose bolts and nuts, and to replace damaged parts.

(2) Deformation and damage of mount rubber, tilt stopper, thrust rod, gears and clutch, and propeller.

Ask to replace damaged or deformed parts.

9. TROUBLE SHOOTING

If you encounter a problem, consult the check list below to find its cause and to take the proper measure.

Your local Tohatsu dealer will always happy to give you assistance and information.

Engine fails to start.	Engine starts but stops soon.	Poor idling	Poor acceleration	Engine speed abnormally high	Engine speed abnormally low	Cannot obtain high engine speeds	Overheating of engine	Possible cause
•	•							Empty fuel tank
•	•	•	•		•	•	•	Incorrect connection of fuel system
•	•	•	•		•	•	•	Air entering in fuel line
•	•	•	•		•	•	•	Deformed or damaged fuel pipe
•	•	•	•		•	•	•	Closed air vent on fuel tank
•	•	•	•		•	•	•	Clogged fuel filter, fuel pump or carburetor
		•	•		•	•	•	Use of improper engine oil
•		•	•			•	•	Use of improper gasoline
•	•	•	•		•	•		Excessive oil in mixture
							•	Shortage of oil in mixture
•			•					Excessive supply of fuel
•	•	•	•		•	•	•	Poor carburetor adjustment
•	•	•	•			•	•	Recirculation pipe broken
•	•	•	•		•	•	•	Spark plugs other than specified
•	•	•	•		•	•		Dirts or bridge on spark plugs

Engine fails to start.	Engine starts but stops soon.	Poor idling	Poor acceleration	Engine speed abnormally high	Engine speed abnormally low	Cannot obtain high engine speeds	Overheating of engine	Possible cause
•	•	•	•		•	•		No or weak spark
						•	•	Insufficient cooling water flow. Clogged or defective pump
		•				•	•	Faulty thermostat
			•	•		•	•	Cavitation
			•	•	•	•	•	Incorrect propeller selection
		•	•	•	•	•	•	Damaged and bent propeller
			•	•		•	•	Improper thrust rod position
			•	•	•	•	•	Unbalanced load position on boat
			•	•	•	•	•	Transom too high or too low
•								Short-circuit of engine stop switch
•		•	•		•	•		Incorrect adjustment of throttle link
•		•	•		•	•		Incorrect adjustment of ignition timing
•								Loose battery terminal connection, corrosion
•								Discharged battery
•								Main switch trouble
•								Lock plate not fitted to stop switch
•								Disconnection of wire or loose ground connection
•								Insufficient battery capacity, loose terminal connection, corrosion

(EP and EF types)

(EP and EF types)

10. ASSOCIATED PARTS

Associated parts		Quantity	Dimensions	Remarks
Service tools	Tool bag	1	10 × 13 mm 21 mm	
	Pliers	1		
	Socket wrench	1		
	Socket wrench	1		
	Socket wrench handle	1		
	Straight edge screwdriver	1		
Spare parts	Starter rope	1	1000 mm NGKB7HS-10 or CHAMPION L82C (Gap: 1.0 mm)	
	Spark plug	1		
	Split pin	1		
*Parts Pack- aged with Engine	Fuel tank	1		
	Primer bulb	1 set		
	Remote control box	1 set		
	Remote control attachment	1 set		
	Flushing plug	1		(EP only) (EP only)

* Not included as standard accessories in some markets.

11. ACCESSORIES



1. Tachometer

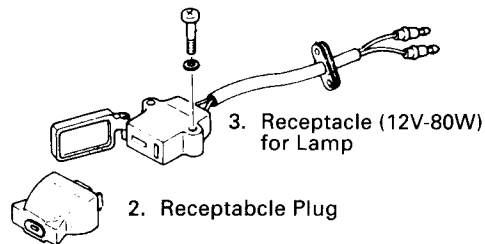

3. Receptacle (12V-80W)
for Lamp

2. Receptacle Plug

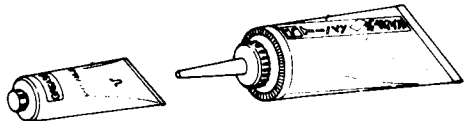

4. Tohatsu Grease
(50g, 250g)

5. Tohatsu Gear Oil
(260cc, 500cc)



6. Touch-up Paint
(300ml)



7. Tohatsu Engine Oil

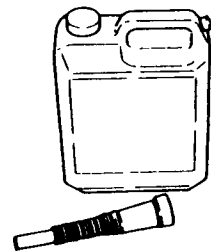

8. Tohatsu Engine Oil

12. PROPELLER TABLE

Light loard boat			Heavy loard boat (Diameter × Pitch)				
Mark	10	9	8.5	8	7	6	
Size	(mm)	234 × 250	234 × 231	234 × 214	234 × 199	234 × 174	234 × 155
	(inch)	9.2 × 9.8	9.2 × 9.1	9.2 × 8.4	9.2 × 7.8	9.2 × 6.9	9.2 × 6.1
M18D	○	S	L, LL	UL	○	○	
M15C	○	○	S	L, LL	UL	○	
M9.9C	○	○	S	L, LL	UL	○	

○: Option

S, L, LL: Transom height

Use a genuine TOHATSU propeller.

For a stainless propeller, use of the one designed specifically for TOHATSU outboard made by POWER TECH is recommended.

A propeller must be selected so that the engine rpm measured at wide open throttle while cruising is within the recommended range, M9.9C: 4500 to 5300 rpm, M15C/M18D: 4750 to 5500 rpm.

13. WIRING DIAGRAM

(M9.9C/M15C/M18D)

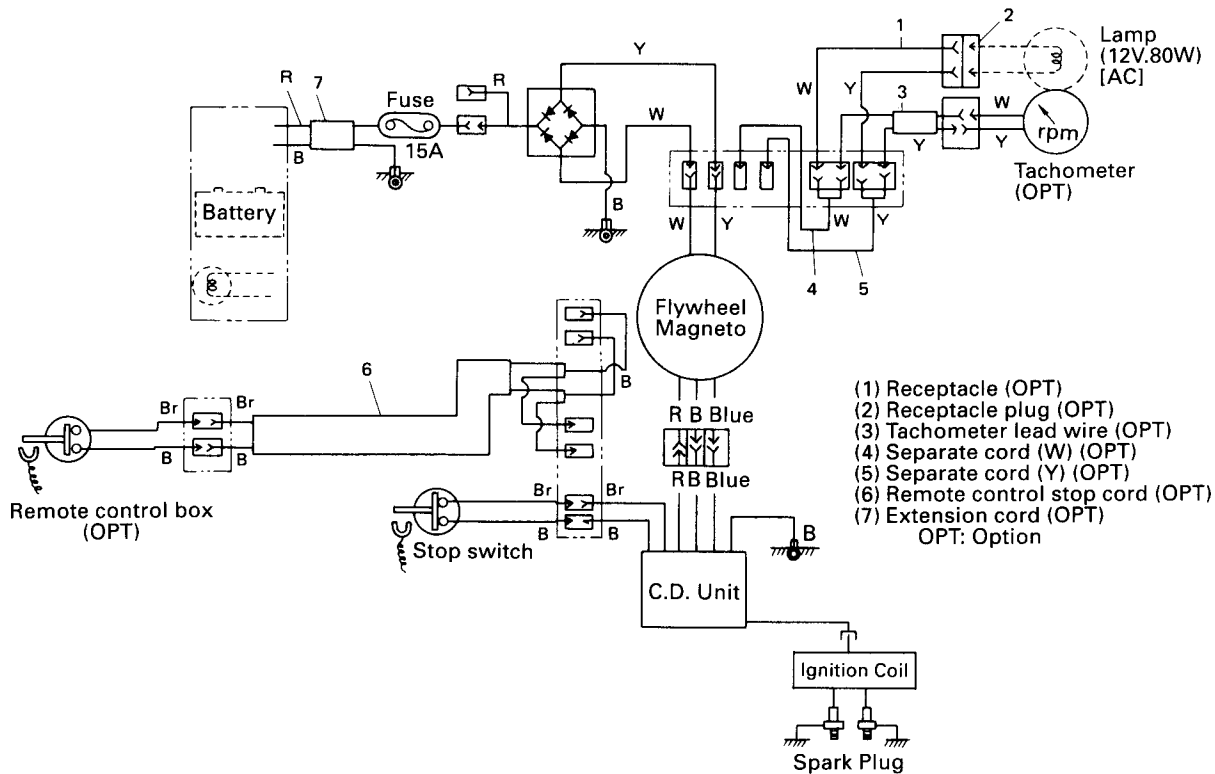

WIRING DIAGRAM

(M9.9CEF / M15CEF / M18DEF)

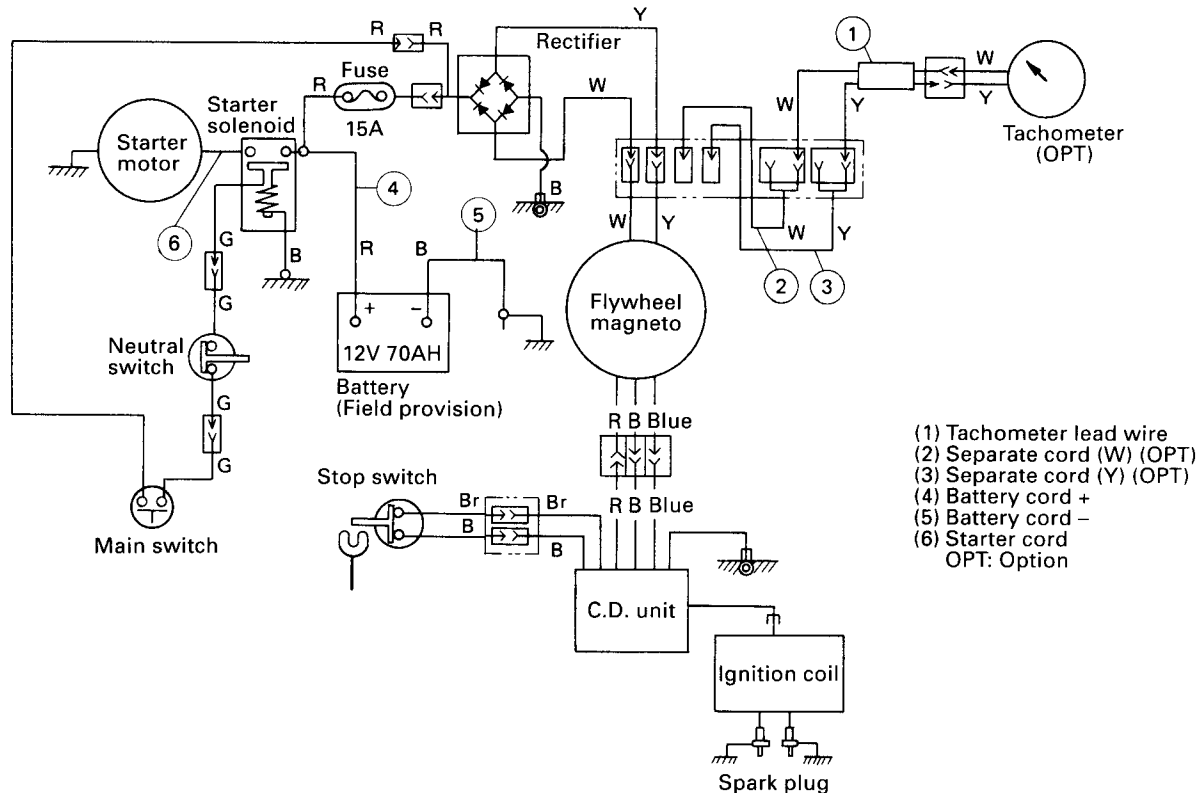

WIRING DIAGRAM

(M9.9CEP / M15CEP / M18DEP)

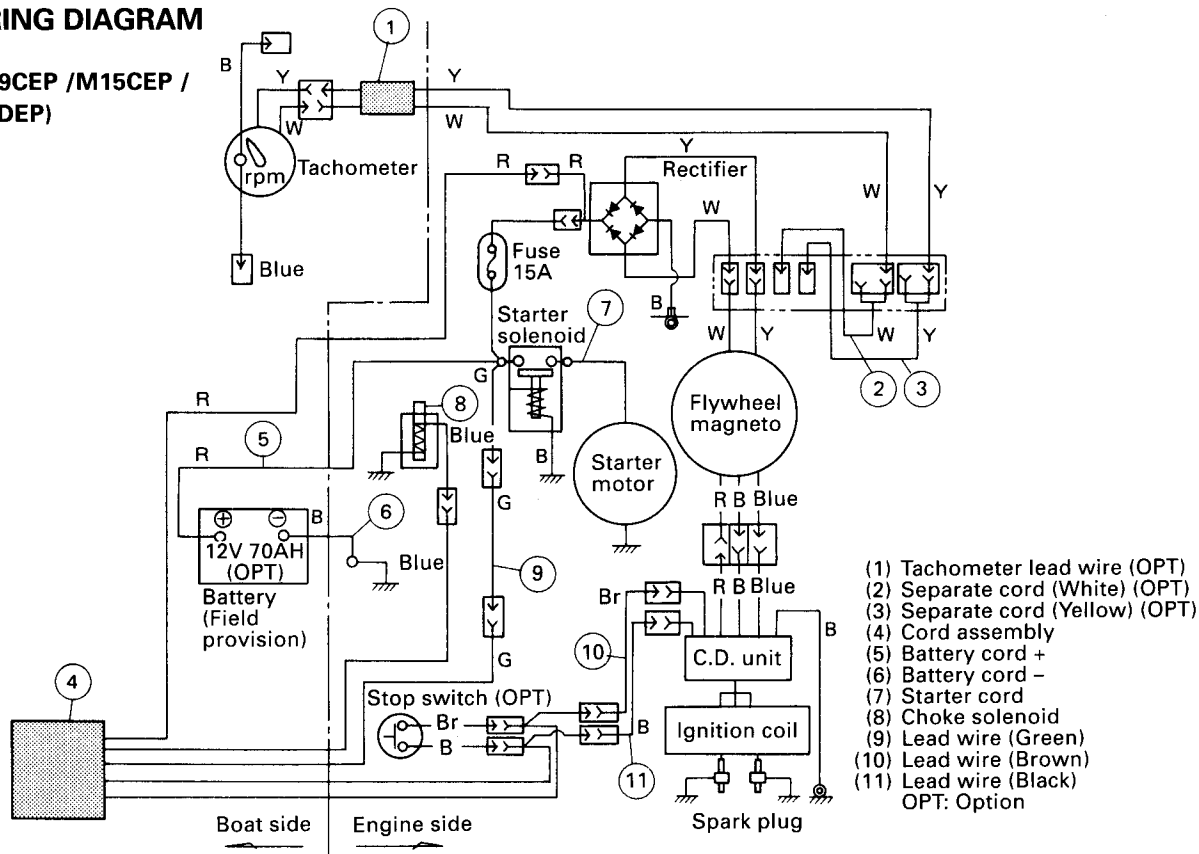



TOHATSU CORPORATION

Address: 4-9, 3-chome, Azusawa, Itabashi-ku, TOKYO 174, Japan
Cable: "TOHATSU TOKYO"
Telex: 272-2051 THT J
Facsimile: TOKYO (03)3969-7885(GII·GIII)
Phone: TOKYO (03)3966-3111